

12

11

10

9

8

7

6

5

4

3

2

1

MODEL NUMBER
ZP36/42K5E-PFJ
ZP34K5E-TFM
ZP34/36/39/42K5E-PFV/TF5/TFD
ZP36/38/39/42K5E-TFM
ZP36/39/42K5E-PFZ
ZH06/09K1P-TFM/PFZ
ZP44K5E-PFV/TF5/TFD/TF7
ZP44K5E-TFM/TFD
ZP36/39/42K5E-TFD
ZP34/36/42K5E-PFV
ZP36/42/44K5E-TF5

SPECIFICATIONS	
ES NO.	DESCRIPTION
ES92-155	CONVERSION-METRIC

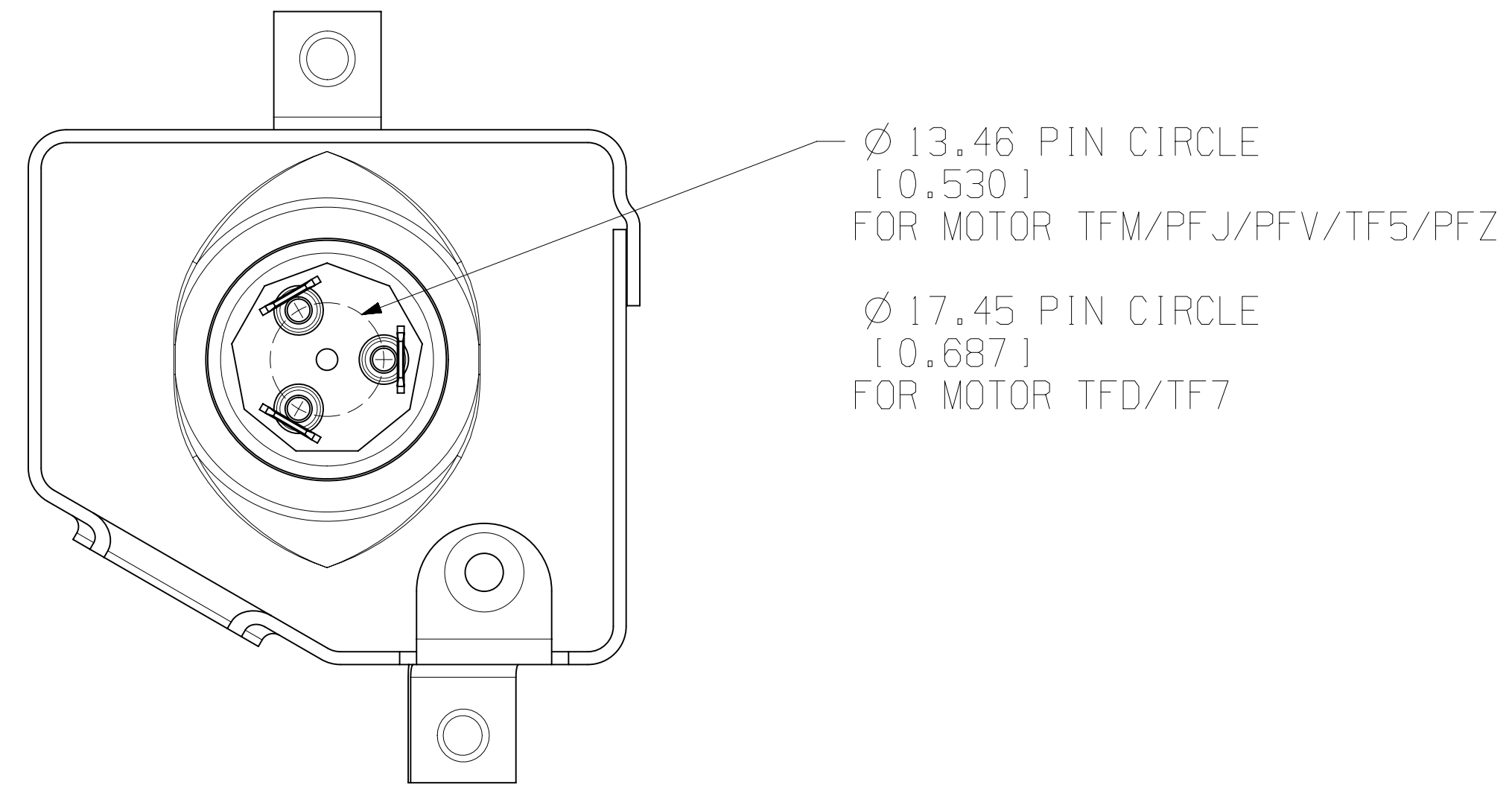
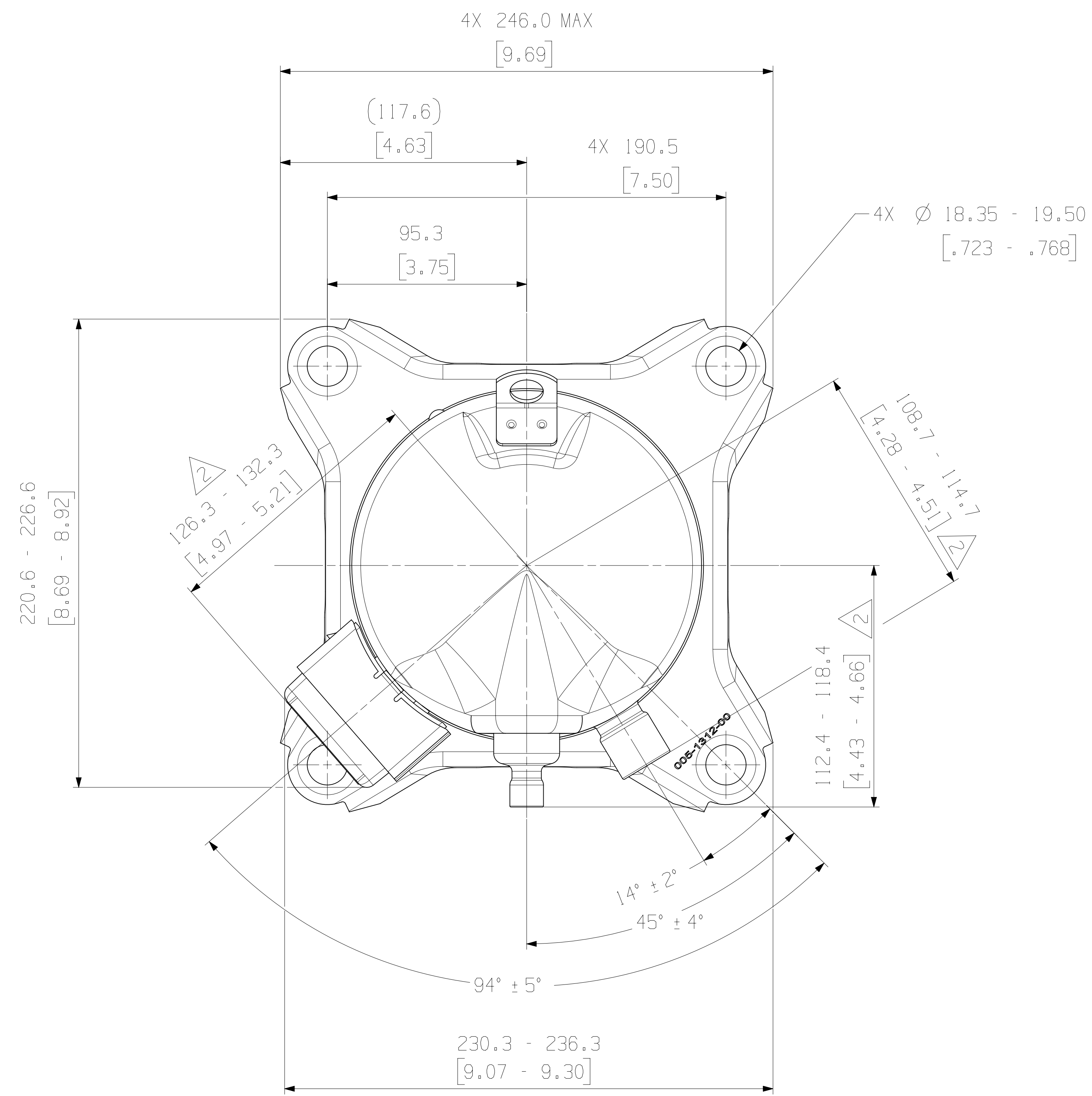

- NOTES:
- ALL TOLERANCES ± 1.50 [0.060] UNLESS OTHERWISE SPECIFIED.
 - THE SUCTION TUBE, DISCHARGE TUBE, RADIAL DIMENSIONS ARE TO BE GAUGED FROM THE CENTER OF THE MOUNTING HOLE PATTERN.
 - TUBE ENDS MUST BE PLUGGED.
 - MOUNTING KIT:

GROMMET DUROMETER	4 FOOT KIT
35-45	527-0116-00

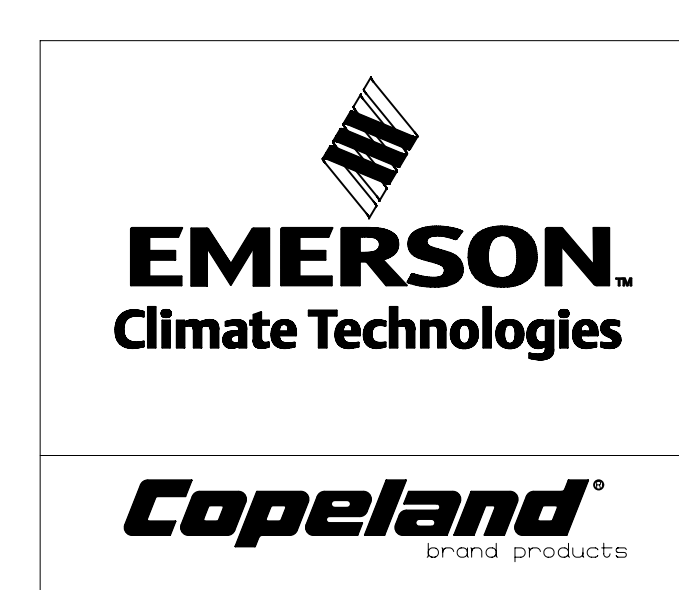
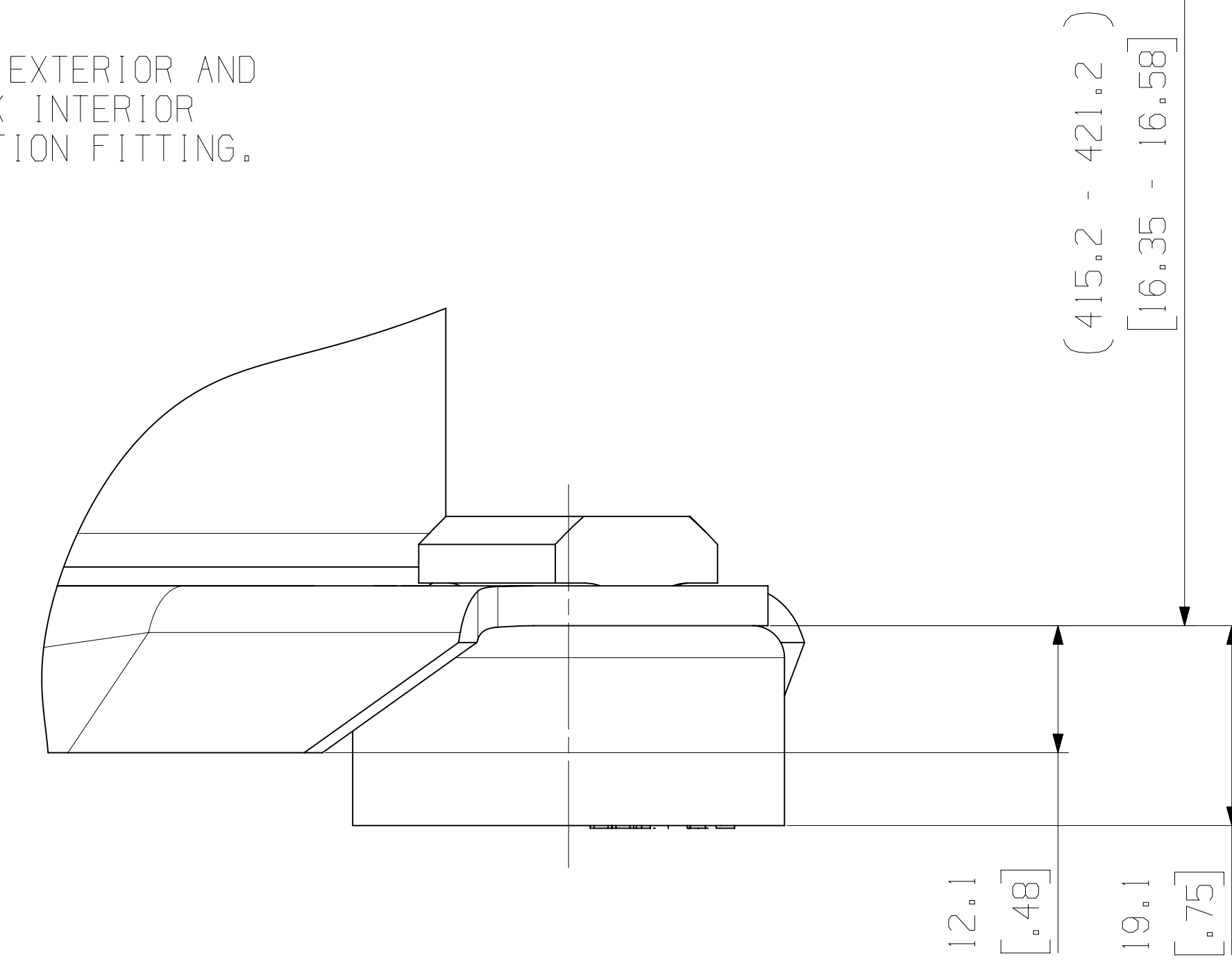
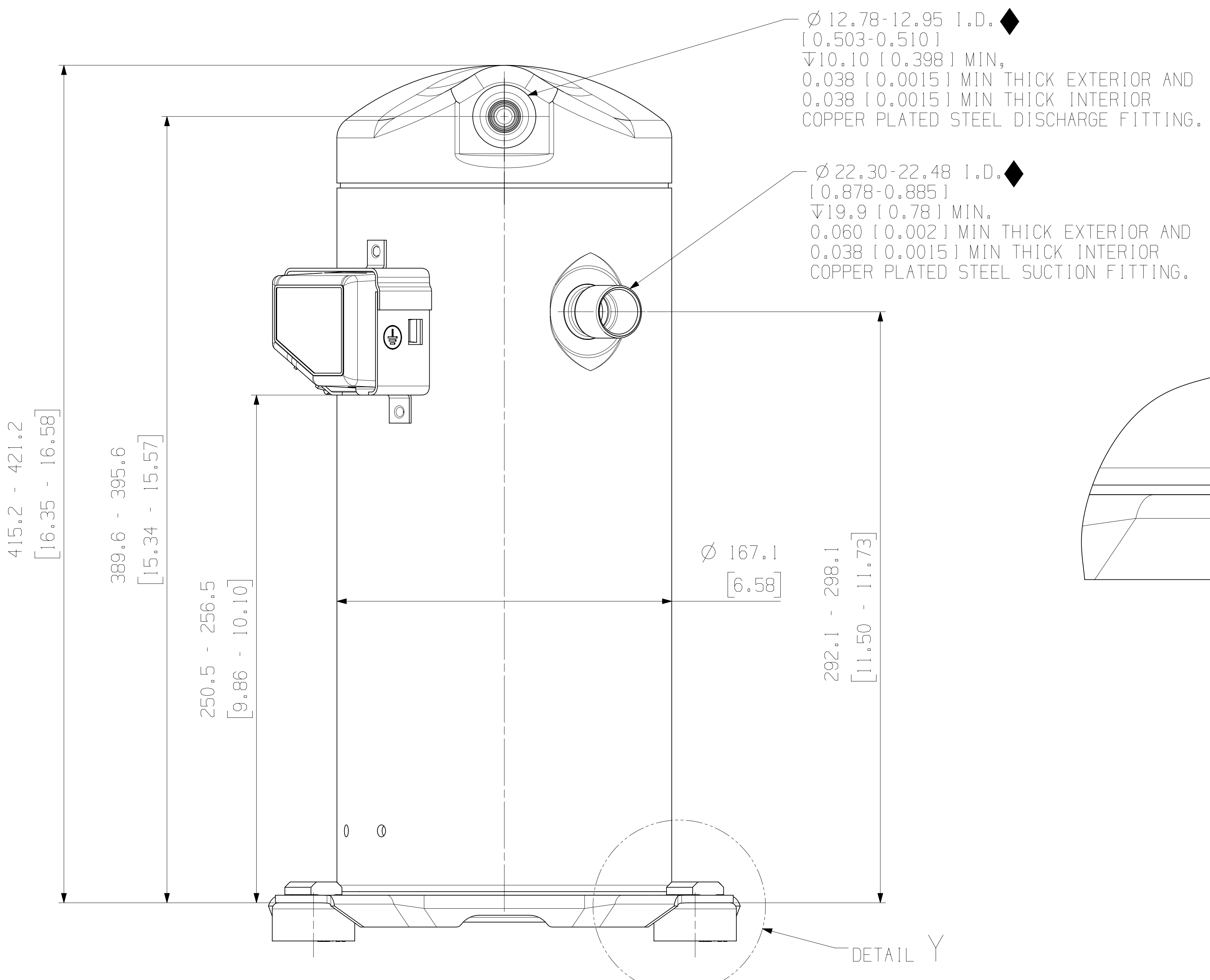
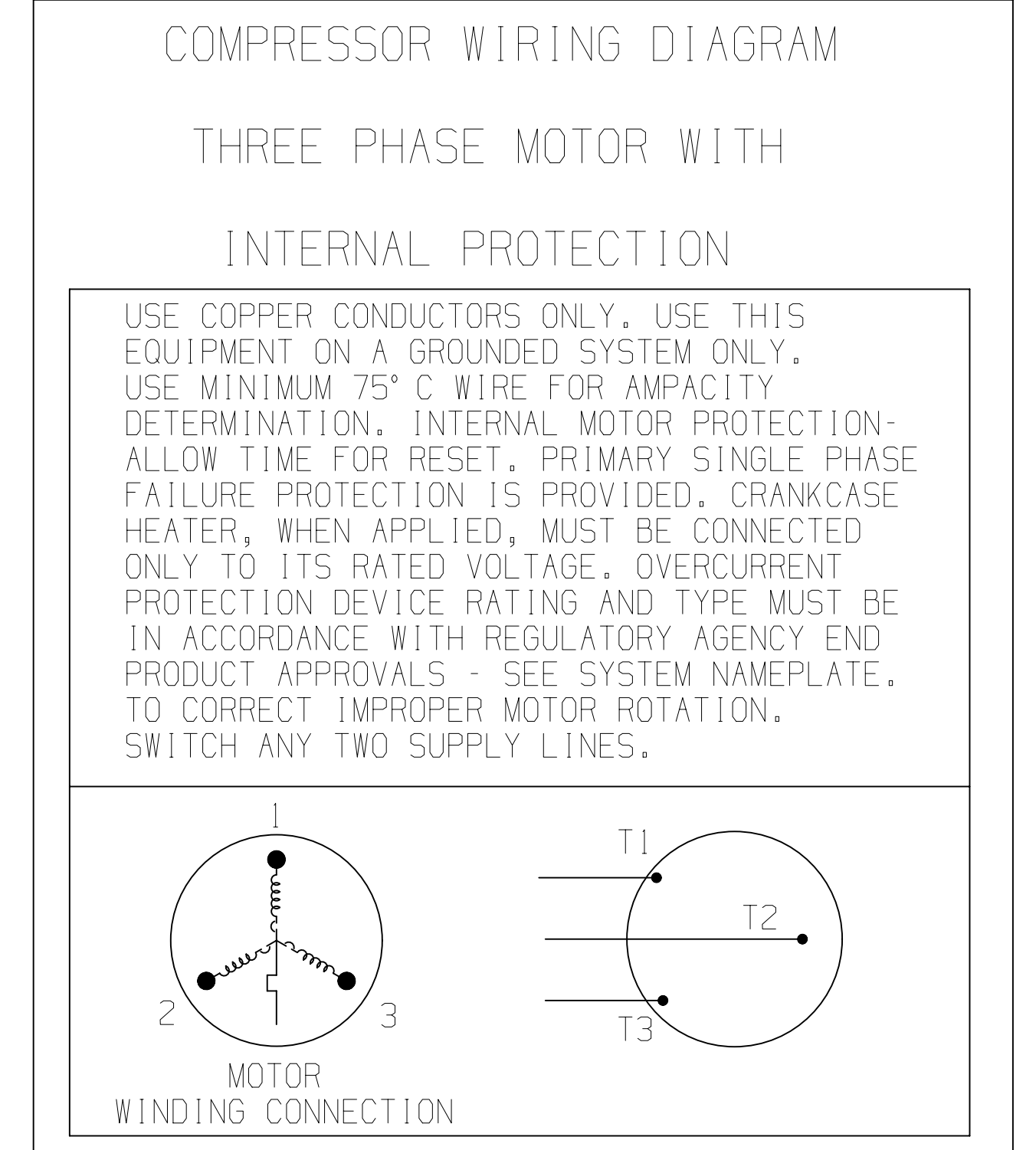
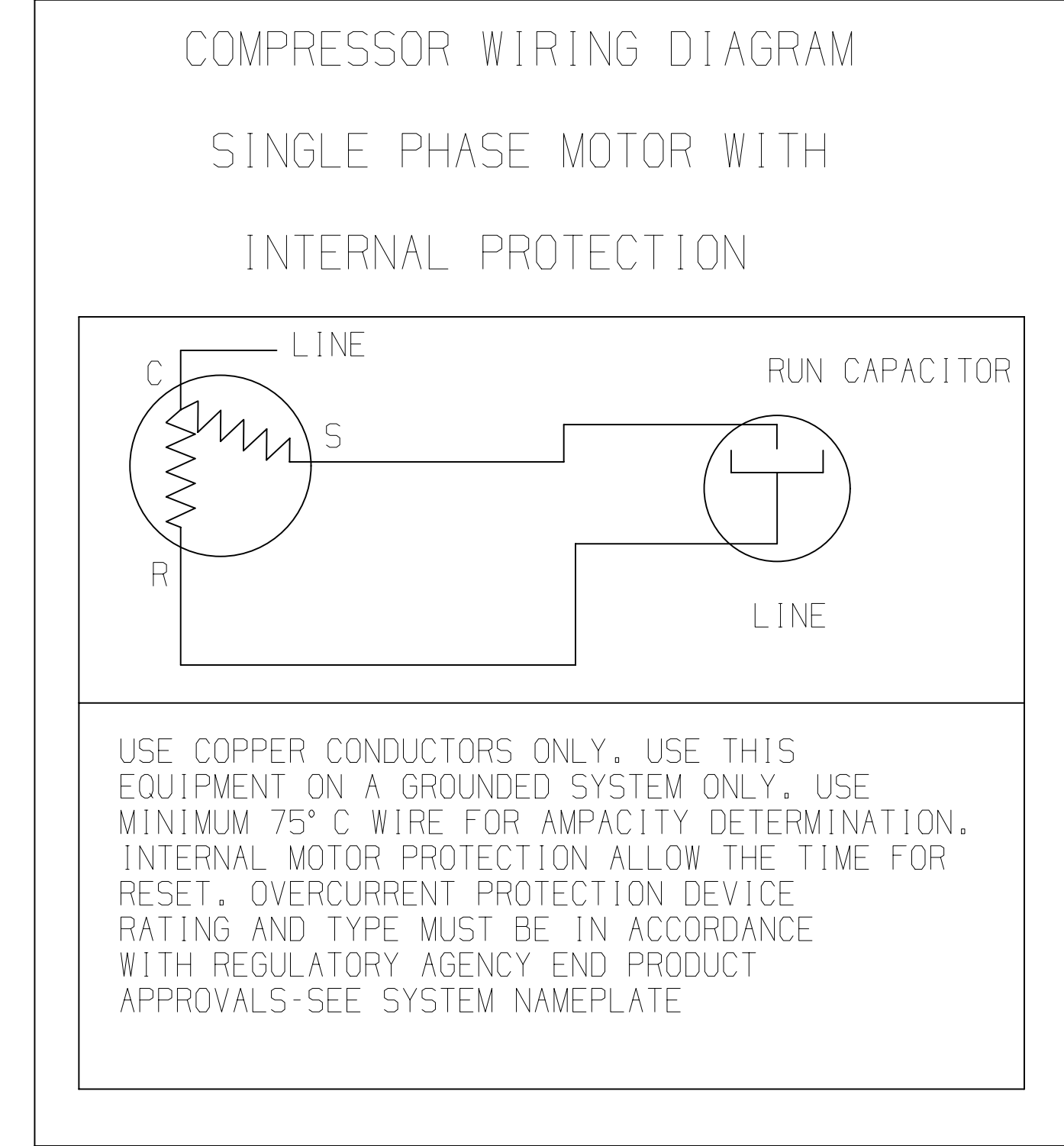
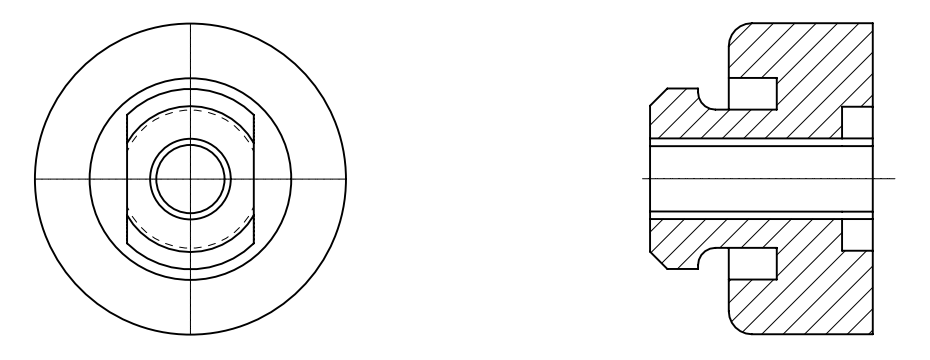

INTERPRET PER ASME Y14.5M-1994 AND EMERSON CLIMATE TECHNOLOGIES, INC. DESIGN STANDARDS DS2002
DO NOT SCALE DRAWINGS
THIRD ANGLE PROJECTION
UNLESS OTHERWISE SPECIFIED DIMENSIONS ARE MILLIMETER OR 1 INCH
1-PLACE :
2-PLACE :
ANGULAR : 1

ECN	NO.	DESCRIPTION	DATE	BY	CHK	APPR
ECN008700	16	ADDED MODEL NUMBER	09-12-14	CYZ	LG	AW
ECN008549	15	ADDED ZP34/36/42K5E-PFV	07-28-14	AZ	AW	AW
ECN008613	14	REDRAWN WITH NX & ADDED ZP36/39K5E-TFD	01-24-14	EL	LG	WS
32-0306-046	0	RELEASED	01-29-07	PBM	MA	KJR

ENG NOTICE NO. REV. NO. REVISIONS DATE BY CHK APPR

CONFIDENTIALITY NOTICE

24 THIS DRAWING AND INFORMATION CONTAINED HEREIN ARE THE EXCLUSIVE PROPERTY OF EMERSON CLIMATE TECHNOLOGIES, INC. AND SHALL BE RETURNED UPON DEMAND AND SHALL NOT BE REPRODUCED IN WHOLE OR IN PART, OR USED TO ANYONE ELSE OR USED, WITHOUT THE WRITTEN CONSENT OF EMERSON CLIMATE TECHNOLOGIES, INC.

MATERIAL SPECIFICATION: N/A

DATE: 01-24-14

SCALE: 3:4

DRAWING NUMBER: REF DWG-WELD COMP ASSM

SUPERSEDES DWG. NO. / REV. NO.: 497-0587-00 / 013

DATE FORMAT: MM-DD-YY

SHEET 1 OF 1

SIZE: 5

12

11

10

9

8

7

6

5

4

3

UNCONTROLLED - DO NOT MODIFY

EMERSON CLIMATE TECHNOLOGIES, INC. - CONFIDENTIAL