

Condensing Unit Technical Data Sheet

Model CGS34TB_N
Voltage 220-240V 50Hz ~1
Refrigerant R134a

APPLICATION

Application High-Medium Back Pressure
 Refrigerant R134a
 Evaporating Temp. -25,0 °C to 10,0 °C
 Expansion Capillar/Valve
 Comp. Cooling Fan cooled
 Max. ambient temp. 43,0 °C

COMPRESSOR

Displacement 34,42 cm³
 Diameter 42,86 mm
 Stroke 23,85 mm
 Oil type ISO VG 32 ESTER
 Oil charge 887 cm³

MOTOR

Nominal Power 1 hp
 Voltage/Frequency 220-240V 50Hz
 Voltage range 198-255 V
 Type CSR
 Phase number 1 PH
 Locked Rotor Amps (LRA) 37,00 A
 Max. Cont. Current (MCC) 9,60 A
 Main W. resist. at 25°C 2,24 Ω
 Start W. resist. at 25°C 7,38 Ω

NOMINAL PERFORMANCE

Cooling Capacity	3.009 W
COP	2,22 W/W
EER	1,91 kCal/Wh
Input Power	1.358 W
Current	6,03 A

ASHRAE

TEST CYCLE CONDITIONS

	HMBP
Evaporating temp. (T _e)	7,2 °C
Condensing temp. (T _c)	55,0 °C
Liquid temp. (T _{liq.})	46,0 °C
Ambient temp. (T _{amb.})	35,0 °C
Suction temp. (T _{suction})	35,0 °C
Voltage/Frequency	220 V 50 Hz

CONDENSER AND FAN DATA

Condenser type	CU-AL
Condenser model	12T 4R
Fan blade (Ø mm / °)	300 / 19
Fan motor	25W 220-240V 50/60Hz

WIRING DIAGRAM

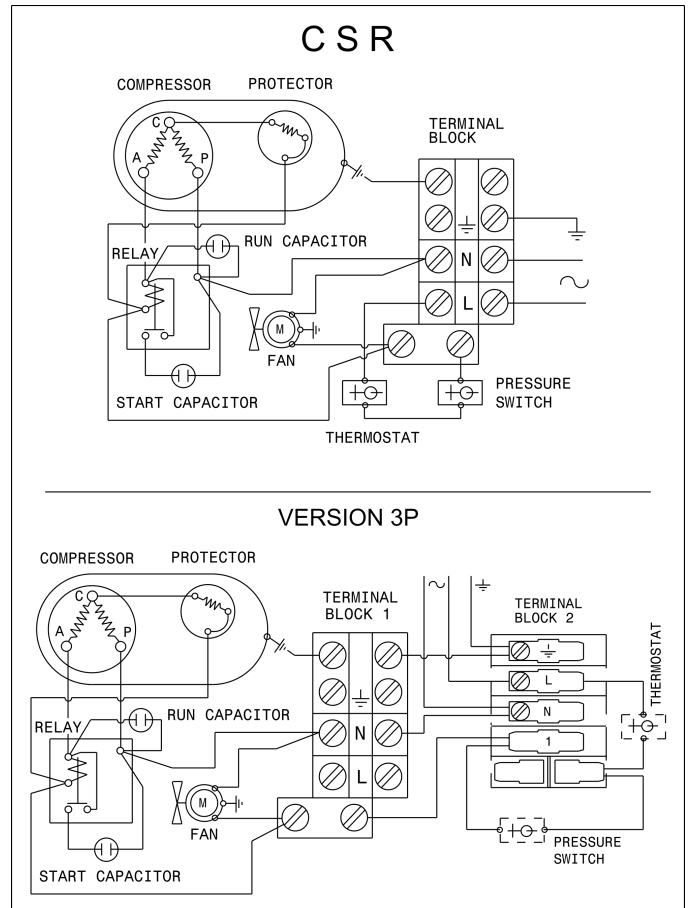

REFRIGERATION CAPACITY (W) Evaporating Temperature (°C)

Model	Motor	-25	-15	-5	5	7.2			10
						W	Winp	A	
CGS34TB_N	CSR	686	1283	1992	2813	3009	1358	6.03	3266

ASHRAE HMBP: Condensing temperature: 55°C, Liquid temperature: 46°C, Suction temperature: 35°C, Ambient temperature: 35°C

Condensing Unit Technical Data Sheet

VERSIONS

VERSION 1	VERSION 2	VERSION 3	VERSION 3P	VERSION 4
Tube	Service valve	Service valve and receiver	Service valve, receiver, pressure switch	Schrader valve on the service port
Suction tube internal diam.: 12,7 mm Discharge tube internal diam.: 8,0 mm Net Weight: 36,5 Kg	Suction valve: 5/8" Discharge valve: 3/8" Net Weight: 37,5 Kg	Receiver vol.: 2,4 l Suction valve: 5/8" Discharge valve: 3/8" Net Weight: 39,0 Kg	Receiver vol.: 2,4 l Suction valve: 5/8" Discharge valve: 3/8" Net Weight: 40,1 Kg	Suction tube internal diam.: 12,7 mm Discharge tube internal diam.: 8,0 mm Net Weight: 36,5 Kg

DIMENSIONS (Version 3 drawing)

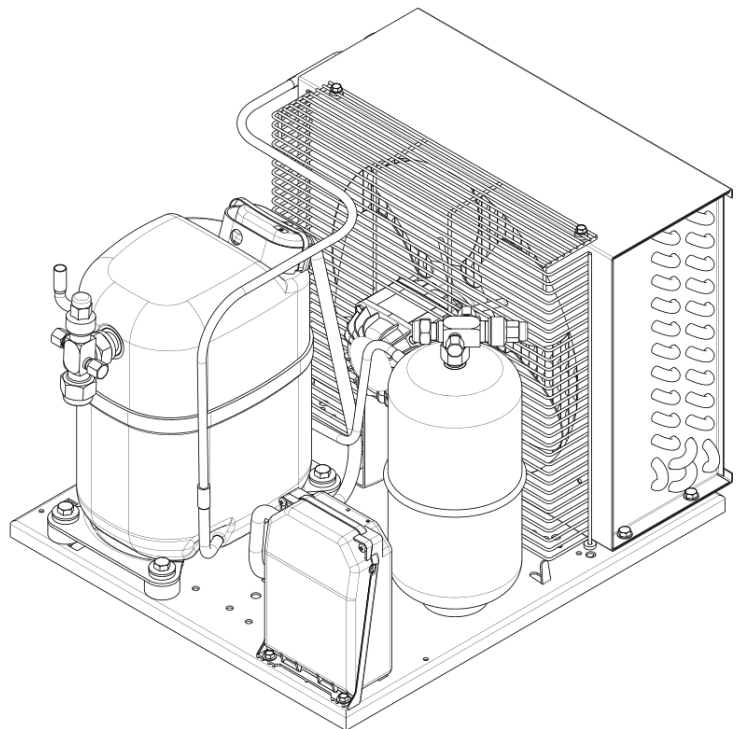
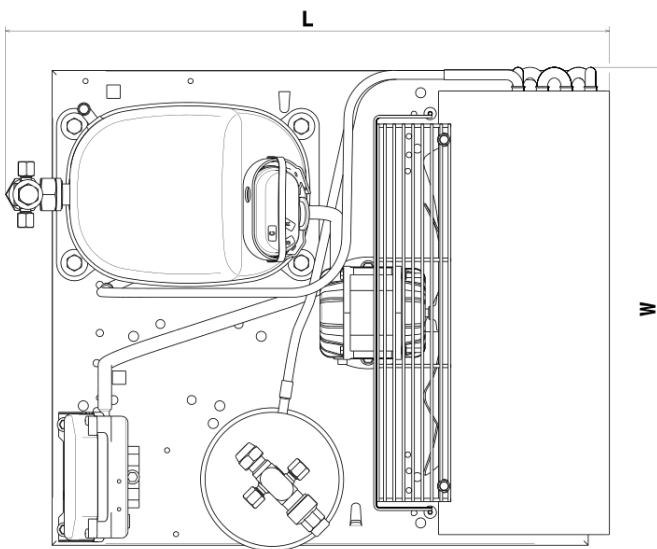
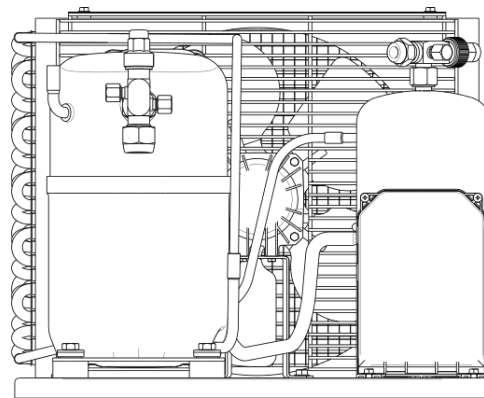
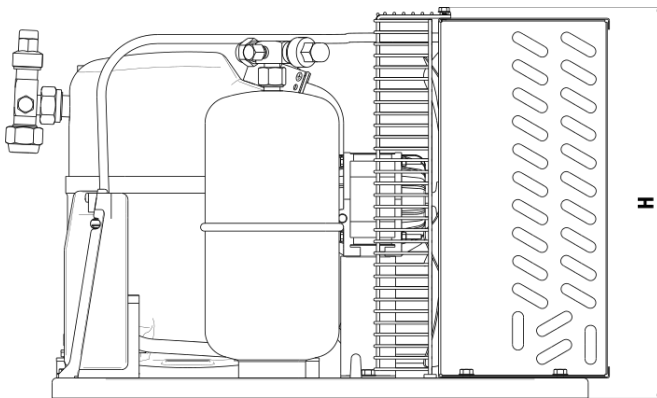

VERSION 1-4 (WxLxH) (mm)	VERSION 2 (WxLxH) (mm)	VERSION 3 (WxLxH) (mm)	VERSION 3P (WxLxH) (mm)
430x505x350	430x535x350	435x535x350	435x535x350