

XH50P - XH55P

Temperature/relative humidity probe with RS485 serial line

- 1. GENERAL WARNINGS 1
- 2. DESCRIPTION 1
- 3. FIXING, DIMENSION AND DRILLING 1
- 4. INSTALLATION ADVISE 1
- 5. WIRING DIAGRAM 2
- 6. DEVICE CONFIGURATION 2
- 7. CASE CLOSURE 2
- 8. CASE OPENING 3
- 9. HOTKEY 3
- 10. ANTI-SWEAT HEATERS REGULATION (WITH ANALOG OUTPUT) 3
- 11. KNOB (ONLY XH55P) 3
- 12. PARAMETER LIST 3
- 13. THE FOLLOWING TABLE DESCRIBES THE DEFAULT PARAMETERS 4
- 14. TECHNICAL DATA 4

1. GENERAL WARNINGS

1.1 PLEASE READ BEFORE USING THIS MANUAL

- This manual is part of the product and should be kept near the instrument for easy and quick reference.
- The instrument shall not be used for purposes different from those described hereunder. It cannot be used as a safety device.
- Check the application limits before proceeding.
- Dixell Srl reserves the right to change the composition of its products, even without notice, ensuring the same and unchanged functionality.

1.2 SAFETY PRECAUTIONS

- Check the supply voltage is correct before connecting the instrument.
- Do not expose to water or moisture: use the controller only within the operating limits avoiding sudden temperature changes with high atmospheric humidity to prevent formation of condensation
- Warning: disconnect all electrical connections before any kind of maintenance.
- Fit the probe where it is not accessible by the End User. The instrument must not be opened.
- In case of failure or faulty operation send the instrument back to the distributor or to "Dixell S.r.l." (see address) with a detailed description of the fault.
- Ensure that the wires for probes, loads and the power supply are separated and far enough from each other, without crossing or intertwining.
- In case of applications in industrial environments, the use of mains filters (our mod. FT1) in parallel with inductive loads could be useful.

2. DESCRIPTION

The XH50P and XH55P devices (version with knob) are temperature/relative humidity probe, but their ability to calculate dew-point of the ambient where they are placed, joined to the available resources (analog output depending on the models) make them like a regulators.

Thanks to its features, the device can be used a anti-sweat heaters controller on refrigeration field, as a zone thermostat or as temperature/humidity probe on air conditioning field. On this manual, there are some instructions that can be useful to configure the device on its main applications.

3. FIXING, DIMENSION AND DRILLING

During the fixing of the device please, pay attention for the procedure that is described below.

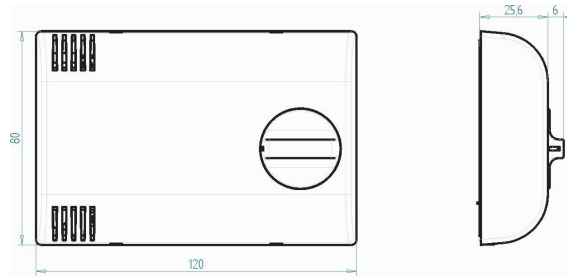

In order to ensure a correct functioning the device has to be placed horizontally (as indicated by the figure above) so that the DIXEL logo can be read, only in this way the drilling on the case allow the correct inflow of air into the case.

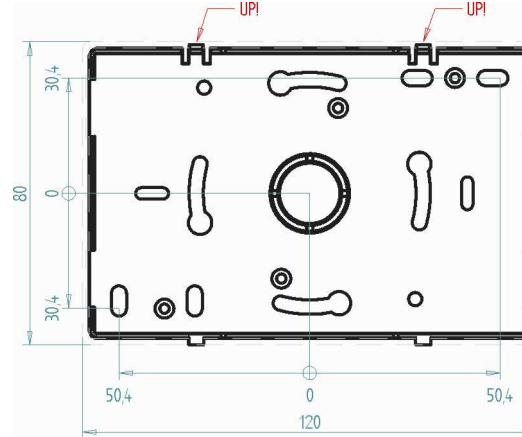

4. INSTALLATION ADVISE

In case of XH55P it's necessary to mount the knob before closing the case. First of all, insert the pivot inside of the knob (1). The insertion of the knob has to be done without effort. The pivot has a small plastic tooth in order to guide you during the insertion. Ended this operation, insert the other extremity of the pivot into the trimmer that is mounted on the board as you can see on the following figure.

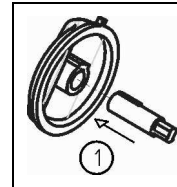

Please pay attention during the fixing of the pivot on the trimmer because the small tooth on the knob has to be on the position described by the following figure (2).

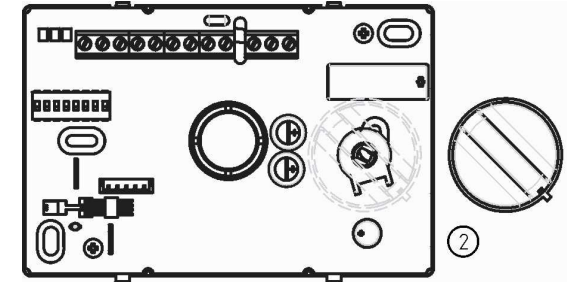

In case of box 503 installation, the cables should be arrive into the devices through the central hole as you can see as follow.

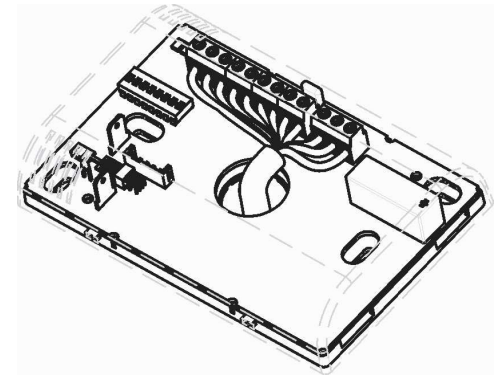

Otherwise, if you need to use wireway so that you cannot use the central hole, it's advised to make a small hole on the bottom of the case after having removed the cover in order to avoid the possibility to damage the electronic board. Please follow the figure nearby.

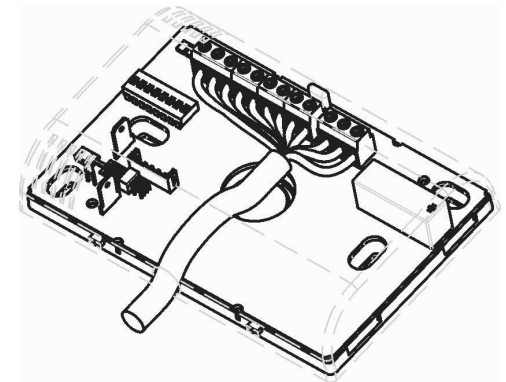

5. WIRING DIAGRAM

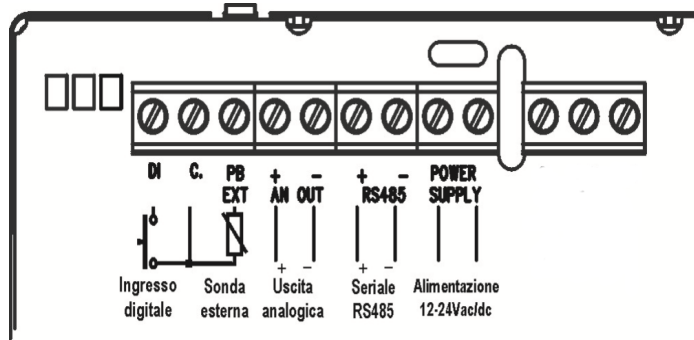

Here you can see the full wiring diagram. The presence/absence of analog output depends on the models.

MEANING OF LEDS

RED LED → there is an alarm. It flashes when an hotkey is detected and during the copy of the parameters with HOTKEY;
GREEN LED → It is ON during normal functioning if the device is powered correctly. It flashes when an hotkey is detected and during the copy of the parameters with HOTKEY;
YELLOW LED → it flashes quickly if there is serial activity and when an hotkey is detected and during the copy of the parameters with HOTKEY;

6. DEVICE CONFIGURATION

The device can communicate with the serial line only if a serial address is selected. This setting has to be done with DIP-SWITCH. The serial address has to be arranged only in case of using the serial line, if the programming procedure will be made by HOTKEY this procedure can be skipped. There are 31 address available as explained by the following table:

SELECTOR	ADDRESS	SELECTOR	ADDRESS
	ADR 1		ADR 1
	ADR 2		ADR 3
	ADR 4		ADR 5

	ADR 6		ADR 7
	ADR 8		ADR 9
	ADR 10		ADR 11
	ADR 12		ADR 13
	ADR 14		ADR 15
	ADR 16		ADR 17
	ADR 18		ADR 19
	ADR 20		ADR 21
	ADR 22		ADR 23
	ADR 24		ADR 25
	ADR 26		ADR 27
	ADR 28		ADR 29
	ADR 30		ADR 31

With the selectors 6 and 7 it's possible to configure the internal/external temperature probe. Please see the following table:

	The probe used to calculate the dew-point is the internal probe		The probe used to calculate the dew-point is the external probe
	The device read only the humidity		

Thanks to the last selector (number 8) it's possible to select the digital input polarity. If the selector is in ON position, the digital input is considered as active when the electrical contact is closed, with the opposite configuration the digital input is active when the electrical contact is opened.

7. CASE CLOSURE

After making the connections, please close the box following the procedure described here below. As described as point ① insert the cover starting from the bottom and perform a rotation as described by point ②. The closing of the case is made when you'll hear a light click ③.

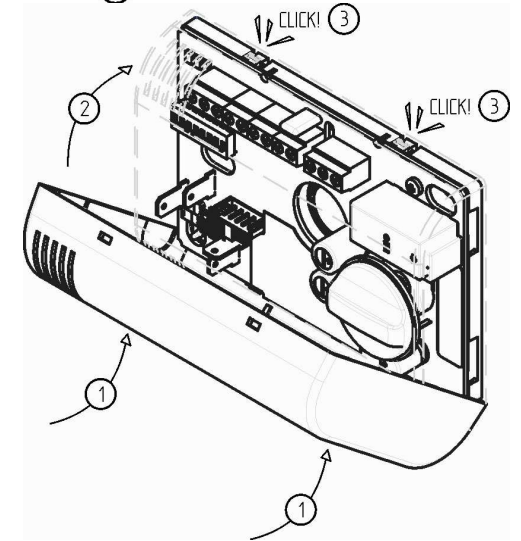

8. CASE OPENING

Please pay attention in order to avoid the damaging of electronic parts. In order to open the case, you should follow the figure below

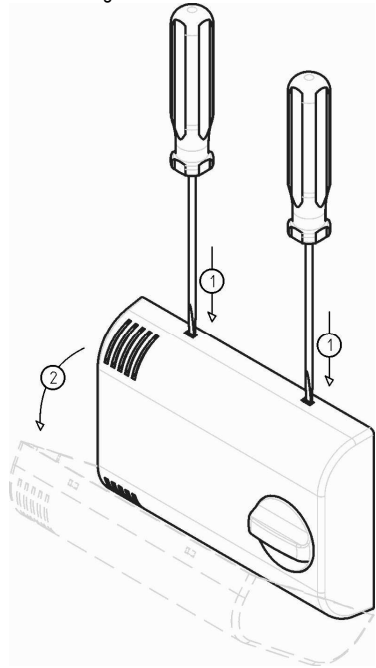

9. HOTKEY

The configuration of the instrument can be done by serial RS485 line or thanks to the **HOTKEY DK0000100**.

HOW TO COPY THE PARAMETERS FROM DEVICE TO HOTKEY

With device powered ON, insert the hotkey in the 5 pin receptacle, the device notices the hotkey presence and the three LEDs flashes for three seconds in order to inform you that the copy is starting. To indicate that the procedure ends up with success the GREEN LED will blink for 5 seconds or otherwise if the procedure ends up without success the RED LED will blink for 5 seconds, in this last case it's necessary to repeat the procedure or to change the HOTKEY.

HOW TO COPY THE PARAMETERS FROM HOTKEY TO DEVICE

With device powered OFF, insert the hotkey in the 5 pin receptacle and switch on the device. The procedure starts automatically and to indicate that the procedure ends up with success the GREEN LED will blink for 5 seconds or otherwise if the procedure ends up without success the RED LED will blink for 5 seconds.

10. ANTI-SWEAT HEATERS REGULATION (WITH ANALOG OUTPUT)

The regulation of the anti-sweat heaters through analog output is obtained by changing **AOC** parameter to **dEP** value. After that, it's possible to refine the regulation using **odr** and **Hy** parameters.

11. KNOB (ONLY XH55P)

In case of XH55P it's present a knob that permits to set an offset respect to the set point of $\pm 3^{\circ}\text{C}$ (this value can be changed with **Ltr** and **Utr** parameters). If the knob is completely turned off all the output are switched off.

12. PARAMETER LIST

- Set** Regulation set point: is the set point for analog output regulation.
- odr** Regulation offset: offset for regulation set point.
- HES** Energy saving offset: is the energy saving offset that is added to the set point when the digital input configured as **11F=ES** is activated.
- rPA** Regulation probe A: selects the first regulation probe between: **nP**=not present, external probe (**Etr**) or internal probe (**int**).
- rPb** Regulation probe B: selects the second regulation probe between: **nP**=not present, external probe (**Etr**) or internal probe (**int**).
- rPE** Regulation percentage between probes A and B: percentage between probe A and probe B. The virtual probe follow the formula:

$$\text{Value} = (\text{rPA} \cdot \text{rPE} + \text{rPb} \cdot (100 - \text{rPE})) / 100$$

- CF** Measurement units: $^{\circ}\text{C}$ =Celsius; $^{\circ}\text{F}$ =Fahrenheit. **WARNING:** after changing measurement unit you have to check all the values of all parameters.
- ods** Start up outputs delay: allows starting the output and the regulation with some delay to allow measurement stabilization.
- rHC** Digital humidity sensor presence: enable or disable the humidity sensor.
- orH** Humidity sensor offset: it permits simple reading offset.
- tdC** Digital temperature sensor activation.
- ot** Digital temperature sensor offset: it permits simple reading offset.
- AuC** External temperature sensor presence: it permits to enable/disable external probe.
- oE** External temperature sensor offset: it permits simple reading offset for auxiliary probe.
- AOC** Analog Output working mode: select the working mode for analog output.
 - lf**: not present, analog output deactivated.
 - Etr**: analog output regulation based on the external temperature probe.
 - int**: analog output regulation based on the internal temperature probe.
 - HPr**: analog output regulation based on the humidity value.
 - dP**: analog output regulation based on the dew-point temperature.
 - dEP**: analog output regulation based on the dew-point.
 - MAn**: analog output goes on **An** value.

The value of analog output can change from 0 to 100% inside of the band define by **LAO** and **UAO** as reported on the following charts.

AoC=Etr, int, HPr, dP and Ant=dir

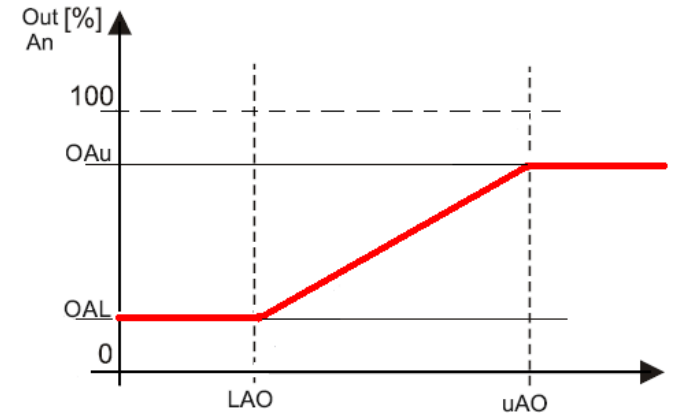

AoC=Etr, int, HPr, dP and Ant=ind

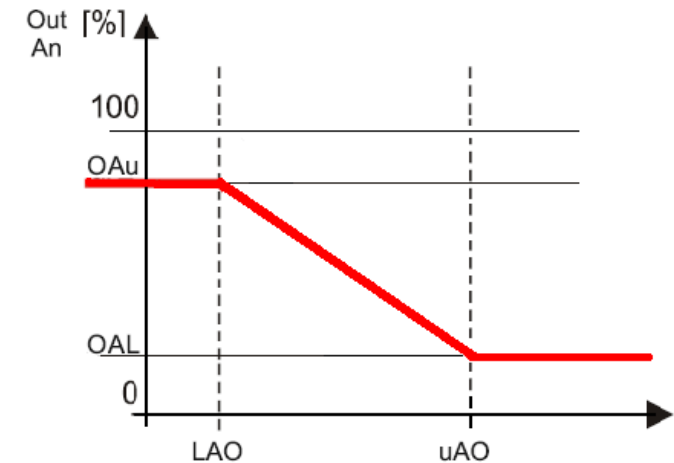

NOTE:
 If **AoC=dEP** the analog output follow the same behavior that is explained at section 10.
 If **AoC=MAn** the analog output works in manual mode with the percentage **An**.

- Ant** Analog Output kind of action: selects direct or reverse functioning for the analog output.
- LAO** Minimum input value: is the value of input that return minimum or maximum output value (respectively for direct functioning or inverse functioning of the analog output).

uAo **Maximum input value:** is the value of input that return minimum or maximum output value (respectively for inverse or direct functioning of the analog output).

oAL **Minimum analog output percentage:** is the minimum value for the analog output.

oAU **Maximum analog output percentage:** is the maximum value for the analog output.

An **MANUAL MODE:** analog output percentage during manual mode (**AoC=MAN**).

oAE **Analog Output safety value:** is the value of the output in case of probe fault.

Ltr **Lower trimmer offset (only for XH55P):** Offset added to setpoint when the trimmer is at minimum value.

Utr **Upper trimmer offset (only for XH55P):** Offset added to setpoint when the trimmer is at maximum value.

ALP **Probe selection for temperature alarm:** nP=not present, alarm disabled; Etr=external probe; int= internal probe; teq=virtual probe.

ALL **Minimum temperature alarm.**

ALU **Maximum temperature alarm.**

AFH **Differential for temperature alarm.**

ALd **Temperature alarm delay.**

dAo **Delay for temperature alarm at start-up.**

diS **Digital input presence:** enable or disable the digital input activity . no= digital input disabled; YES=digital input is present.

idF **Digital Input function:** defines the working mode for digital input (!!!WARNING!!!: the digital input polarity is defined following the paragraph 6) between En= regulation enabling; ES=energy saving; inA= inversion of kind of action (relative to CH).

idd **Digital Input delay:** is the delay of activation of digital input.

13. THE FOLLOWING TABLE DESCRIBES THE DEFAULT PARAMETERS:

Label	Description	Range	Value
SEt	Set point	[-40.0°C ÷ 80.0°C] [-40°F ÷ 176°F]	18.0
odr	Regulation offset	[-12.0°C ÷ 12.0°C] [-21°F ÷ 21°F]	1.0
HES	Temperature increase during energy saving cycle	[-20.0°C ÷ 20.0°C] [-36°F ÷ 36°F]	0.0
rPA	Regulation probe A	nP(0); Etr(1); int(2)	ext
rPb	Regulation probe B	nP(0); Etr(1); int(2)	nP
rPE	Virtual probe percentage	0 ÷ 100%	100
CF	Measurement units	°C(0); °F(1)	°C
odS	Start up outputs delay	0 ÷ 255 sec	0
rHC	Humidity probe presence	no(0); YES(1)	YES
orH	Humidity probe calibration	-10 ÷ 10 %HR	0
tdC	Internal probe temperature presence	no(0); YES(1)	YES
ot	Internal probe temperature calibration	[-12.0°C ÷ 12.0°C] [-21°F ÷ 21°F]	0.0
AuC	External temperature probe presence	no(0); YES(1)	YES

oE	External temperature probe calibration	[-12.0°C ÷ 12.0°C] [-21°F ÷ 21°F]	0.0
AOC	Analog output configuration	nP(0); Etr(1); int(2); HPr(3); dP(4); dEP(5); MAN(6)	HPr
Ant	Analog output action: direct or inverse	dir(0); in (1)	dir
LAo	Lower input limit for analog output value	[-40.0°C ÷ uAO] [-40°F ÷ uAO] [0% ÷ uAO]	0
uAo	Upper input limit for analog output value	[LAo ÷ 80.0°C] [LAo ÷ 176°F] [LAo ÷ 100%]	100
oAL	Minimum analog output percentage	0% ÷ oAU	0
oAU	Maximum analog output percentage	oAL ÷ 100%	100
An	MANUAL MODE: Analog output percentage	0 ÷ 100%	0
oAE	Analog output percentage during probe error	0 ÷ 100%	0
Ltr	Lower trimmer offset (Only for XH55P)	[-12.0°C ÷ Utr] [-21°F ÷ Utr]	-3.0
Utr	Upper trimmer offset (Only for XH55P)	[Ltr ÷ 12.0°C] [Ltr ÷ 21°F]	3.0
ALP	Probe selection for temperature alarms	nP(0); Etr(1); int(2); TEq(3)	nP
ALL	Minimum temperature alarm	[-40.0°C ÷ ALU] [-40°F ÷ ALU]	-40.0
ALU	Maximum temperature alarm	[ALL ÷ 80.0°C] [ALL ÷ 176°F]	80.0
AFH	Differential for temperature alarm recovery	[0.1°C ÷ 25.5°C] [1°F ÷ 45°F]	1.0
ALd	Temperature alarm delay	0 ÷ 255 min	0
dAo	Delay of temperature alarm at start up	0 ÷ 255 min	0
diS	Digital input presence	no(0); YES(1)	YES
idF	Digital input configuration	En(0); ES(1); inA(2)	En
idd	Digital input delay	0 ÷ 60sec	0
rEL	Software release	sola lettura	1.1
Ptb	Map code	sola lettura	1

Operating temperature: -10 ÷ 60°C
Storing temperature: -25 ÷ 60°C
Data storing: on the non-volatile memory (FLASH)
Pollution degree: normal
Software class: A
Rated impulsive voltage: 2500V

14. TECHNICAL DATA

Case: for box 503 and wall mounting. 80x120x25.6mm
Connections: screw terminal blocks ≤ 2.5mm²
Power supply: 12 ÷ 24Vac or 12 ÷ 40Vdc. **Use CLASS 2 Power supply ONLY.**
Power absorption: 3VA max
NTC input: 10Kohm@25°C
Digital input: free of voltage
Outputs: 0÷10Vdc output impedance 47 ohm 10mA maximum
Measuring and regulation range: Humidity 1 ÷ 99% R.H. ± 3.5%
 Temperature -40 ÷ 80°C (-40 ÷ 176°F)



Dixell S.r.l. - 32010 Pieve d'Alpago (BL) ITALY - Z.I. Via dell'Industria, 27
 Tel. +39.0437.9833 r.a. - Fax +39.0437.989313 - www.dixell.com - dixell@emerson.com