

XJR40D

RELAY MODULE

INDEX

1. General Warning_____1
 2. General description_____1
 3. Programming keyboard (KB1 PRG)_____1
 4. on-board keyboard_____1
 5. Use of LEDS_____1
 6. Switching on/off the outputs_____1
 7. Section parameters programming_____2
 8. Security Options_____2
 9. On-board keyboard_____2
 10. Serial Addresses_____2
 11. Use of the programming "HOT KEY "_____2
 12. Installation and mounting_____2
 13. Electrical connections_____2
 14. Serial Communication_____3
 15. Technical data_____3
 16. Connections_____3
 17. Default setting values_____3

1. GENERAL WARNING

1.1 PLEASE READ BEFORE USING THIS MANUAL

- This manual is part of the product and should be kept near the instrument for easy and quick reference.
- The instrument shall not be used for purposes different from those described hereunder. It cannot be used as a safety device.
- Check the application limits before proceeding.

1.2 SAFETY PRECAUTIONS

- Check the supply voltage is correct before connecting the instrument.
- Do not expose to water or moisture: use the controller only within the operating limits avoiding sudden temperature changes with high atmospheric humidity to prevent formation of condensation
- Warning: disconnect all electrical connections before any kind of maintenance.
- Fit the probe where it is not accessible by the End User. The instrument must not be opened.
- In case of failure or faulty operation send the instrument back to the distributor or to "Dixell s.p.a." (see address) with a detailed description of the fault.
- Consider the maximum current which can be applied to each relay (see Technical Data).
- Ensure that the wires for probes, loads and the power supply are separated and far enough from each other, without crossing or intertwining.
- In case of applications in industrial environments, the use of mains filters (our mod. FT1) in parallel with inductive loads could be useful.

2. GENERAL DESCRIPTION

XJR40D is a module with 4 on-board relays and 4 digital Input free voltage contact (DI). All the outputs can be switched by the local or remote keyboard. This module is equipped with the serial output RS485, so it can be connected to the XWEB series or to a ModBUS-RTU compatible monitoring system. XJR, DIN RAIL format, is without display and has to be programmed by means of the keyboard KB1 PRG. It is also possible to program it with a programming "Hot key".

3. PROGRAMMING KEYBOARD (KB1 PRG)

The module programming must be done with programming keyboard KB1 PRG.



SET : In programming mode confirm the parameter change.

UP : In programming mode it browses the parameter codes or increases the displayed value.

DOWN : In programming mode it browses the parameter codes or decreases the displayed value.

SECTION: not used.

PRG : Show first output status, ot digit starts blinking.

COPY: not used.

Entering parameter section: DOWN+SET for 3": the display shows first parameter label.

4. ON-BOARD KEYBOARD

Using the on-board keys it is possible to switch the outputs.



5. USE OF LEDS

There are 5 leds on-board : 4 yellow, 1 green.

LED	Led status	Function
Yellow	ON	Output is on
Yellow	OFF	Output is off
Green	ON	Module is On
Green	OFF	Module is Off

On-board leds:

iIF	Relay	Digital Input	On-board leds
ALL	ON	ON	3s blinking, 3s ON
ALL	OFF	ON	3s blinking, 3s OFF
ALL	ON	OFF	ON
ALL	OFF	OFF	OFF
SiA	ON	ON	3s blinking, 3s ON
SiA	OFF	ON	3" blinking, 3s OFF
SiA	ON	OFF	ON
SiA	OFF	OFF	OFF
rEL	ON	ON	ON
rEL	OFF	ON	OFF
rEL	ON	OFF	ON
rEL	OFF	OFF	OFF

Remote keyboard: using different lables with particular meanings it shows outputs and DI status.

	Output sequence		
	ON	OFF	ALL
Digital Input 1	i1n	i1F	i1A
Digital Input 2	i2n	i2F	i2A
Digital Input 3	i3n	i3F	i3A
Digital Input 4	i4n	i4F	i4A
Relay 1	o1n	o1F	
Relay 2	o2n	o2F	
Relay 3	o3n	o3F	
Relay 4	o4n	o4F	

The sequence is interrupted each time outputs or DI change status. The display shows the new status label blinking for 2s, then the standard sequence starts over.

N.B. Other leds status is available. Go to §Use of the programming "HOT KEY "

6. SWITCHING ON/OFF THE OUTPUTS

By using Remote Keyboard:

1. The section menu is entered by pushing and releasing the " PRG " key. The status of the first relé will be displayed.
By pressing PRG next relay output will be displayed.
2. By pressing " UP " or " DOWN " keys the relé is switched On or Off.
3. To exit the menu press SET+UP or wait for 15s. This action depends on the security setup, please read §Security Options

By using Local Keyboard:

1. Push for 2s the key corresponding to the output you want to switch. This action depends on the security setup, please read §Security Options

Via RS485:

- If a monitoring unit is present, you can switch on/off the outputs using it. This action depends on the security setup, please read \$Security Options

7. SECTION PARAMETERS PROGRAMMING

7.1 GENERAL PARAMETERS PR1

There are some general parameters common for all the sections. To be able to display and modify them:

- press the "**DOWN+SET**" for 3s.

Seq it is used to set priority mode among these choices:

- Seq = Loc** remote keyboard and RS485 commands are ignored.
Seq = rEM on-board keyboard and RS485 are ignored.
Seq = Ser on-board keyboard and the remote one are ignored.
Seq = All no security restriction.

Rel Release software: (read only)

Ptb Parameter table: (read only) shows the factory default settings.

7.2 EXIT

If no key is pressed for more than 15 seconds, the instrument reverts to main display mode.

7.3 TO ENTER THE PARAMETER LIST

To enter the parameter list press "**DOWN+SET**" for 3 seconds.

7.4 HOW TO CHANGE THE PARAMETER VALUE

Each parameter is identified by a special alphanumeric code (label).

To change the parameter value, do as follows:

- Browse the parameter list by using "**UP**" or "**DOWN**" until the required parameter is displayed.
- Press the "**SET**" key to display its value.
- Use "**UP**" or "**DOWN**" to change its value.
- Press "**SET**" to store the new value and skip to the following parameter.

TO EXIT: Press "**SET**" + "**UP**" or wait 15s without touching any key.

NOTE: the set value is stored, even when the procedure is exited, by waiting the timeout to expire without pressing "**SET**".

7.5 PARAMETER LIST

Label	Descrizione	Valori impostabili
r1P	Relè 1 polarity	cL = norm. close / oP = norm. open
i1c	Priority switching output 1	di = d. Input / SEr = serial
r2P	Relè 2 polarity	cL = norm. close / oP = norm. open
i2c	Priority switching output 2	di = d. Input / SEr = serial
r3P	Relè 2 polarity	cL = norm. close / oP = norm. open
i3c	Priority switching output 3	di = d. Input / SEr = serial
r4P	Relè 4 polarity	cL = norm. close / oP = norm. open
i4c	Priorità switching output 4	di = d. Input / SEr = serial
i1P	Polarity digital input 1	cL = close / oP = open / nP = not present
i1F	Setup digital input 1	rEL = relè / ALL = allarm / StA = status
dd1	Delay digital input 1	0 ÷ 120 min.
i2P	Polarity digital input 2	cL = close / oP = open / nP = not present
i2F	Setup digital input 2	rEL = relè / ALL = allarm / StA = status
dd2	Delay digital input 2	0 ÷ 120 min.
i3P	Polarity digital input 3	cL = close / oP = open / nP = not present
i3F	Setup digital input 3	rEL = relè / ALL = allarm / StA = status
dd3	Delay digital input 3	0 ÷ 120 min.
i4P	Polarity digital input 4	cL = close / oP = open / nP = not present
i4F	Setup digital input 4	rEL = relè / ALL = allarm / StA = status
dd4	Delay digital input 4	0 ÷ 120 min.
Adr	Serial address	1 ÷ 247
Seq	Priority sequence	Loc = local / rEM = remote keyb. / SEr = serial All = no priority
Ptb	Parameter table	1 ÷ 999
rEL	Software release	Read only
Pr2	Password protected menu	Read only

8. SECURITY OPTIONS

Using a correct parameters programming it is possible to limit the interaction with the output.

Using parameter:

Seq it is used to set priority mode among these choices:

- Seq = Loc** remote keyboard and RS485 commands are ignored.
Seq = rEM on-board keyboard and RS485 are ignored.
Seq = Ser on-board keyboard and the remote one are ignored.
Seq = All no security restriction.

i1F,...i4F if it sets to rEL, the output relè switches each time there is a variation in the corresponding DI.

i1C,...i4C it sets the switching output priority between a command coming from the RS485 or a command coming from a DI variation. It works only if the corresponding i1F,...i4F is set to rEL.

9. ON-BOARD KEYBOARD

9.1 RESETTING ALARM

To reset an alarm push any key. The remote keyboard displays "rST" label blinking.

9.2 LOCK/UNLOCK THE KEYBOARD

How to lock

Using on-board keyboard: press for 3s. **1 + 4** this lock the local keyboard and the remote one.

Using remote keyboard: press for 3s **Up + Down** this lock the remote keyboard and the local one.

When the keyboard is locked all the keys are disabled and pressing one of them produce only a beep and on the remote display will appear the label "PoF"

How to unlock.

Using on-board keyboard: press for 3s. **2 + 4** this unlock the local keyboard and the remote one.

Using remote keyboard: press for 3s **Up + Down** this unlock the remote keyboard and the local one.

9.3 MODIFY SEQ PARAMETER

Press for 3s. **1 + 3** this will set Seq=loc. regardless of the previous setting.

Press for 3s. **2 + 3** this will revert Seq parameter to the previous setting.

9.4 STAND BY FUNCTION

Press for 3s. **1 + 2** it switches OFF the controller. Pressing again for 3s. **1 + 2** switched On the controller.

10. SERIAL ADDRESSES

Factory defaults is Adr=1.

11. USE OF THE PROGRAMMING "HOT KEY "

The unit can UPLOAD or DOWNLOAD the parameter list from its own E2 internal memory to the "Hot Key" and vice-versa.

11.1 DOWNLOAD (FROM THE "HOT KEY" TO THE INSTRUMENT)

- Turn OFF the instrument by means of the ON/OFF key, remove the remote keyboard if present, insert the "Hot Key" and then turn the Controller ON.
- Automatically the parameter list of the "Hot Key" is downloaded into the Controller memory, the "DoL" message is blinking. After 10 seconds the instrument will restart working with the new parameters.
- Turn OFF the instrument remove the "Hot Key".

At the end of the data transfer phase the instrument displays the following messages:

All 4 on-board leds blink, it means right programming. The instrument starts regularly with the new programming.

Only on-board leds 1 and 3 stay on, it means failed programming. In this case turn the unit off and then on if you want to restart the download again or remove the "Hot key" to abort the operation.

11.2 UPLOAD (FROM THE INSTRUMENT TO THE "HOT KEY")

- The remote keyboard is needed. Push for 5s. "Up", the "uPL" message appears.
- A timeout of 30s starts. Remove the remote keyboard and insert the "Hot key".
- Wait for the end of the procedure.

At the end of the data transfer phase the instrument displays the following messages:

All 4 on-board leds blink, it means right programming. The instrument starts regularly with the new programming.

Only on-board leds 1 and 3 stay on, it means failed programming. In this case turn the unit off and then on if you want to restart the download again or remove the "Hot key" to abort the operation.

12. INSTALLATION AND MOUNTING

XJP modules shall be mounted on an omega DIN rail (3). The ambient temperature range allowed for correct operation is 0 ÷ 60 °C. Avoid places subject to strong vibrations, corrosive gases, excessive dirt or humidity. The same recommendations apply to probes. Let air circulate by the cooling holes.

13. ELECTRICAL CONNECTIONS

The instruments are provided with screw terminal block to connect cables with a cross section up to 2,5 mm². Before connecting cables make sure the power supply complies with the instrument's requirements. Separate the input connection cables from the power supply cables, from the outputs and the power connections. Do not exceed the maximum current allowed on each relay, in case of heavier loads use a suitable external relay.

14. SERIAL COMMUNICATION

All the alarms, the states and the data measured by the modules XJR can be sent by serial RS485 to the monitoring system.

15. TECHNICAL DATA

- Housing: self extinguishing ABS.
- Case: 4 DIN modules 70x85 mm; depth 61mm.
- Mounting: DIN RAIL mounted in a omega (3) din rail .
- Connections: Screw terminal block ≤ 2,5mm² wiring.
- Power supply: 230Vac, ± 10% 50/60Hz (opt. 115Vac, ± 10% 50/60Hz; 24Vac, ± 10% 50/60Hz)
- Power absorption: 6 VA.
- Digital inputs: 4 free voltage contact
- RS485 output : RS485 serial output with ModBUS-RTU protocol.
- Data storing: on the non-volatile memory (EEPROM).
- Operating temperature: 0+60 °C.
- Storage temperature: -30+85 °C.
- Relative humidity: 20+85% (no condensing)

16. CONNECTIONS

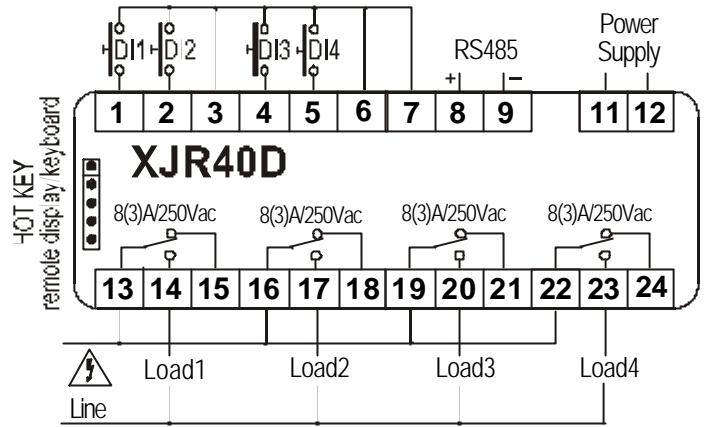

17. DEFAULT SETTING VALUES

SECTION PARAMETERS			
XJR40D			
LABEL	DEFAULT VALUE	PARAMETER	RANGE
r1P	cL	Relè 1 polarity	cL = norm. close / oP = norm. open
i1c	SEr	Priority switching output 1	di = d. Input / SEr = serial
r2P	cL	Relè 2 polarity	cL = norm. close / oP = norm. open
i2c	SEr	Priority switching output 2	di = d. Input / SEr = serial
r3P	cL	Relè 2 polarity	cL = norm. close / oP = norm. open
i3c	SEr	Priority switching output 3	di = d. Input / SEr = serial
r4P	cL	Relè 4 polarity	cL = norm. close / oP = norm. open
i4c	SEr	Priority switching output 4	di = d. Input / SEr = serial
i1P	cL	Polarity digital input 1	cL = close / oP = open / nP = not present
i1F	StA	Setup digital input 1	rEL = relè / ALL = allarm / StA = status
dd1	0	Delay digital input 1	0 ÷ 120 min.
i2P	cL	Polarity digital input 2	cL = close / oP = open / nP = not present
i2F	StA	Setup digital input 2	rEL = relè / ALL = allarm / StA = status
dd2	0	Delay digital input 2	0 ÷ 120 min.
i3P	cL	Polarity digital input 3	cL = close / oP = open / nP = not present
i3F	StA	Setup digital input 3	rEL = relè / ALL = allarm / StA = status
dd3	0	Delay digital input 3	0 ÷ 120 min.
i4P	cL	Polarity digital input 4	cL = close / oP = open / nP = not present
i4F	StA	Setup digital input 4	rEL = relè / ALL = allarm / StA = status
dd4	0	Delay digital input 4	0 ÷ 120 min.
Adr	1	Serial address	1 ÷ 247
Seq	All	Priority sequence	Loc = local / rEM = remote keyb. / SEr = serial All = no priority
Ptb	1	Parameter table	1 ÷ 999
rEL	--	Software release	Read only
Pr2	--	Password protected menu	Read only

Dixell s.p.a. Z.I. Via dell'Industria, 27
32010 Pieve d'Alpago (BL) ITALY
tel. +39 - 0437 - 98 33 - fax +39 - 0437 - 98 93 13
E-mail:dixell@dixell.com -
<http://www.dixell.com>