

UNEK2168GK

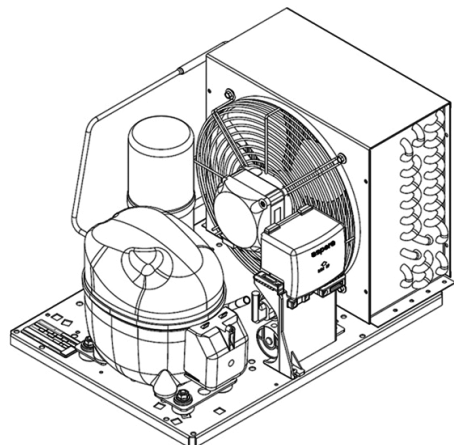

ENGINEERING CODE
559FA8204AA



POWER SUPPLY
220-240 V 50 Hz



MOTOR TYPE
CSR



REFRIGERANT
R-452A



APPLICATION
LBP



STANDARD
EN13215_RG20



COOLING CAPACITY
372 W



EFFICIENCY
0.89 W/W



DATA

GENERAL DATA

Model UNEK2168GK

ACCESSORIES

Discharge valve FLARE 1/4" 2110085

Suction valve FLARE 3/8" 2110059

CONDENSING COMPONENTS

Compressor NEK2168GK LBP

Condenser 4R11T 2451217

Refrigerant R-404A

Expansion Device C-V

Fan Blade Diameter 254

Fankit 16W 254/28/5B 1996609

MECHANICAL DATA

Air Flow	460 m ³ /h
Height	296 mm
Receiver	1.1 L
Shaft Power	16
Weight	23 Kg
Width	340 mm
Length	499 mm

PERFORMANCE

TESTED CONDITIONS

Tested Refrigerant	R-452A
Tested Application	LBP
Tested Standard	EN13215_RG20

RATED POINTS

Ambient Temperature °C	Evaporating Temperature °C	Cooling Capacity W	Efficiency W/W	Consumo de Potencia W
32	-35	372	0.89	418

Test Condition: Subcooling 3 K, Return Gas 20 °C.

PERFORMANCE CURVE

Ambient Temperature 25°C

Evaporating Temperature °C	Cooling Capacity W	Efficiency W/W	Consumo de Potencia W
-40	349	0.85	410
-30	554	1.12	493
-25	711	1.31	541
-20	894	1.51	593
-15	1098	1.68	652
-10	1314	1.83	718

Test Condition: Subcooling 3 K, Return Gas 20 °C.

PERFORMANCE CURVE

Ambient Temperature 32°C

Evaporating Temperature °C	Cooling Capacity W	Efficiency W/W	Consumo de Potencia W
-40	304	0.82	372
-30	479	1.02	467
-25	619	1.19	521
-20	785	1.35	580
-15	971	1.50	646
-10	1168	1.63	718

Test Condition: Subcooling 3 K, Return Gas 20 °C.

PERFORMANCE CURVE

Ambient Temperature 43°C

Evaporating Temperature °C	Cooling Capacity W	Efficiency W/W	Consumo de Potencia W
-40	272	0.69	395
-30	387	0.76	509
-25	496	0.87	572
-20	630	0.98	640
-15	782	1.09	715

Test Condition: Subcooling 3 K, Return Gas 20 °C.

ENVELOPE

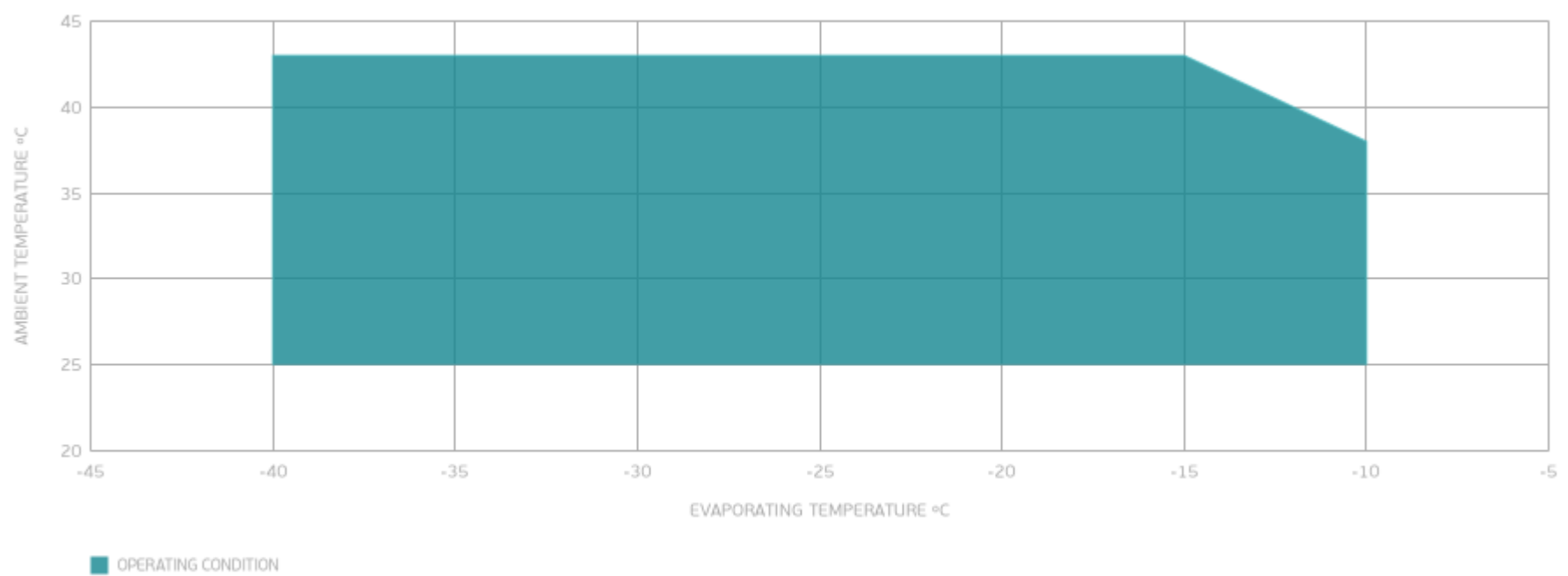

EXTERNAL DIMENSIONS

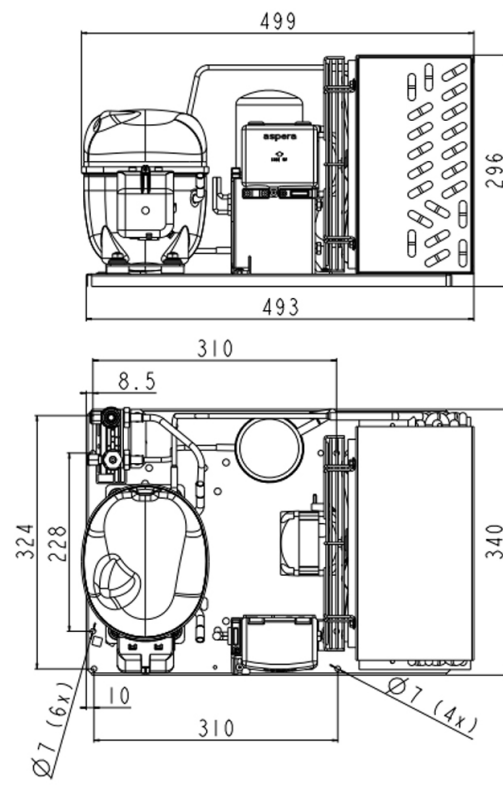

WIRING DIAGRAM

