

UNJ2212GS

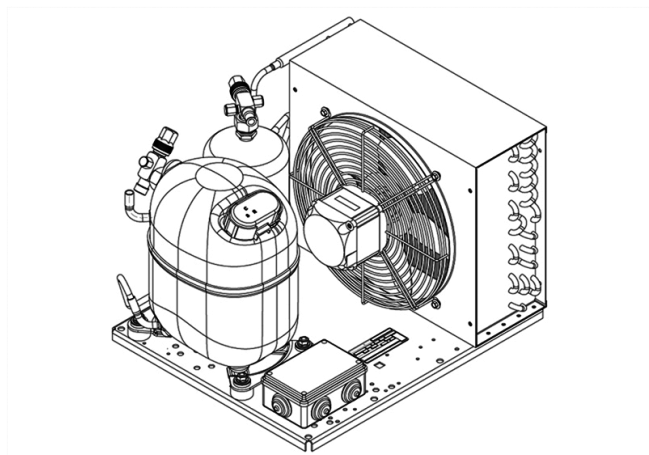

ENGINEERING CODE
647AM5603AA



REFRIGERANT
R-404A



POWER SUPPLY
380-420 V 50 Hz



APPLICATION
LBP



MOTOR TYPE
3PH



STANDARD
EN13215_RG20



COOLING CAPACITY
908 W



EFFICIENCY
1.18 W/W

CE

ECODESIGN
COMPLIANT

DATA

GENERAL DATA

Model UNJ2212GS

ACCESSORIES

Discharge valve SOLDER 3/8" 2110049

Suction valve SOLDER 5/8" 2110054

CONDENSING COMPONENTS

Compressor NJ2212GS LBP

Condenser 3R12T 2451140

Refrigerant R-404A

Expansion Device C-V

Fan Blade Diameter 275

Fankit 34W/400V 275/31 1996582

MECHANICAL DATA

Air Flow	800 m ³ /h
Height	324 mm
Receiver	2.3 L
Shaft Power	34
Weight	38 Kg
Width	410 mm
Length	481 mm

PERFORMANCE

TESTED CONDITIONS

Tested Refrigerant	R-404A
Tested Application	LBP
Tested Standard	EN13215_RG20

RATED POINTS

Ambient Temperature °C	Evaporating Temperature °C	Cooling Capacity W	Efficiency W/W	Consumo de Potencia W
32	-35	908	1.18	771

Test Condition: Subcooling 3 K, Return Gas 20 °C.

PERFORMANCE CURVE

Ambient Temperature 25°C

Evaporating Temperature °C	Cooling Capacity W	Efficiency W/W	Consumo de Potencia W
-40	718	1.19	606
-30	1266	1.41	898
-25	1546	1.46	1059
-20	1826	1.48	1230
-15	2104	1.49	1411
-10	2378	1.48	1601

Test Condition: Subcooling 3 K, Return Gas 20 °C.

PERFORMANCE CURVE

Ambient Temperature 32°C

Evaporating Temperature °C	Cooling Capacity W	Efficiency W/W	Consumo de Potencia W
-40	683	1.09	627
-30	1146	1.24	926
-25	1393	1.28	1091
-20	1648	1.30	1268
-15	1908	1.31	1454
-10	2170	1.31	1652

Test Condition: Subcooling 3 K, Return Gas 20 °C.

PERFORMANCE CURVE

Ambient Temperature 43°C

Evaporating Temperature °C	Cooling Capacity W	Efficiency W/W	Consumo de Potencia W
-40	465	0.80	580
-30	850	0.95	899
-25	1074	1.00	1077
-20	1317	1.04	1267
-15	1575	1.07	1468

Test Condition: Subcooling 3 K, Return Gas 20 °C.

ENVELOPE

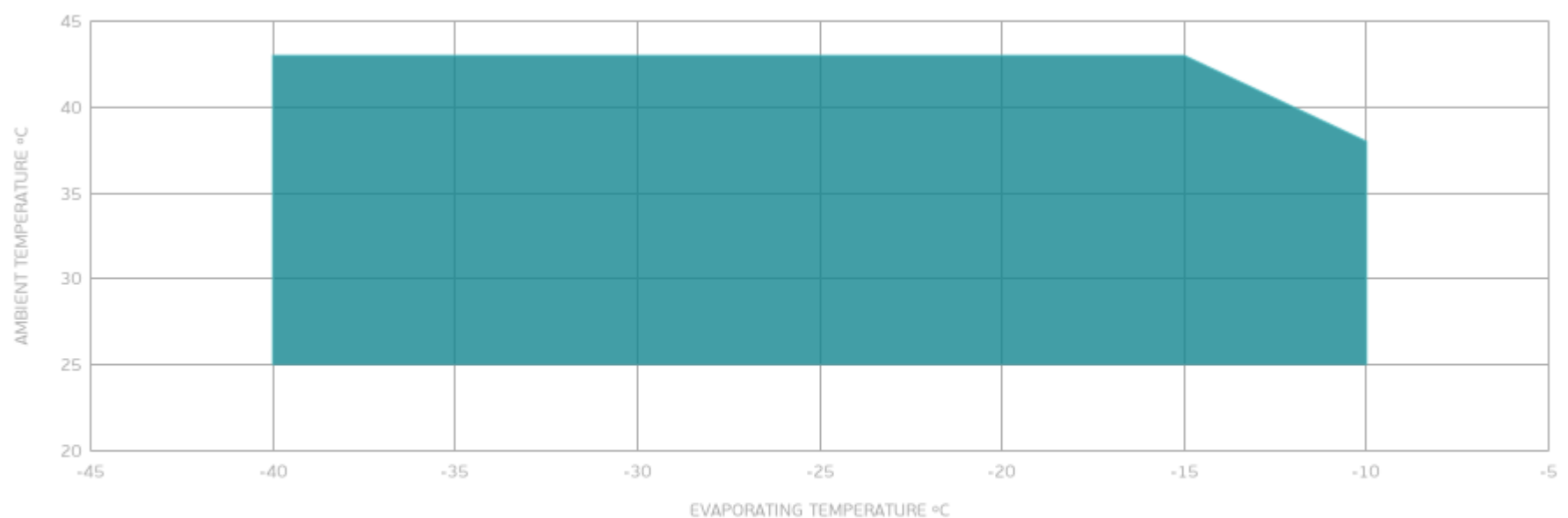

■ OPERATING CONDITION

EXTERNAL DIMENSIONS

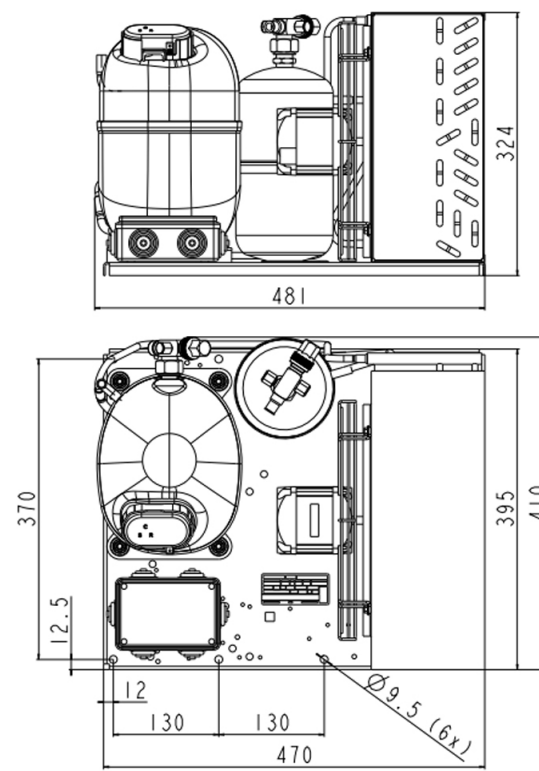

WIRING DIAGRAM

