

UNT2180GK

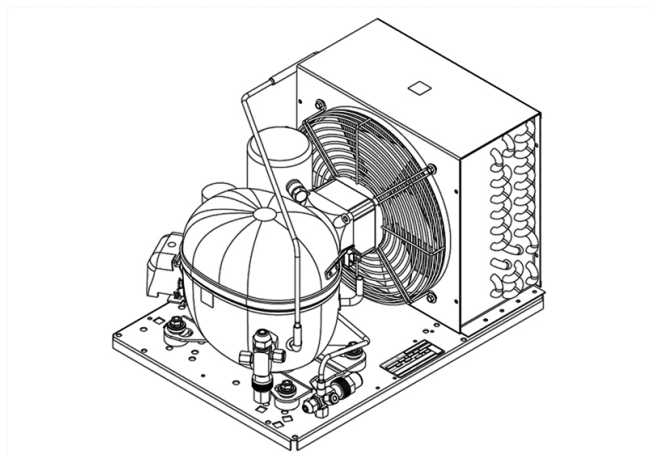

ENGINEERING CODE
503HA5612AA



REFRIGERANT
R-404A



POWER SUPPLY
220-240 V 50 Hz



APPLICATION
LBP



MOTOR TYPE
CSIR



STANDARD
EN13215_RG20



COOLING CAPACITY
573 W



EFFICIENCY
0.99 W/W

CE

ECODESIGN
COMPLIANT

DATA

GENERAL DATA

Model UNT2180GK

ACCESSORIES

Discharge valve SOLDER 1/4" 2110047

Suction valve SOLDER 3/8" 2110049

CONDENSING COMPONENTS

Compressor NT2180GK LBP

Condenser 4R11T 2451217

Refrigerant R-404A

Expansion Device C-V

Fan Blade Diameter 254

Fankit 16W 254/28/5B 1996579

MECHANICAL DATA

Air Flow	460 m ³ /h
Height	296 mm
Receiver	1.2 L
Shaft Power	16
Weight	28 Kg
Width	340 mm
Length	474 mm

PERFORMANCE

TESTED CONDITIONS

Tested Refrigerant	R-404A
Tested Application	LBP
Tested Standard	EN13215_RG20

RATED POINTS

Ambient Temperature °C	Evaporating Temperature °C	Cooling Capacity W	Efficiency W/W	Consumo de Potencia W
32	-35	573	0.99	578

Test Condition: Subcooling 3 K, Return Gas 20 °C.

PERFORMANCE CURVE

Ambient Temperature 25°C

Evaporating Temperature °C	Cooling Capacity W	Efficiency W/W	Consumo de Potencia W
-40	441	0.86	515
-30	781	1.24	632
-25	951	1.35	705
-20	1126	1.42	791
-15	1313	1.47	892
-10	1515	1.50	1012

Test Condition: Subcooling 3 K, Return Gas 20 °C.

PERFORMANCE CURVE

Ambient Temperature 32°C

Evaporating Temperature °C	Cooling Capacity W	Efficiency W/W	Consumo de Potencia W
-40	420	0.83	505
-30	729	1.11	655
-25	891	1.21	737
-20	1065	1.29	827
-15	1257	1.35	929
-10	1470	1.41	1044

Test Condition: Subcooling 3 K, Return Gas 20 °C.

PERFORMANCE CURVE

Ambient Temperature 43°C

Evaporating Temperature °C	Cooling Capacity W	Efficiency W/W	Consumo de Potencia W
-40	310	0.65	476
-30	564	0.83	678
-25	714	0.92	775
-20	885	1.01	874
-15	1082	1.11	976

Test Condition: Subcooling 3 K, Return Gas 20 °C.

ENVELOPE

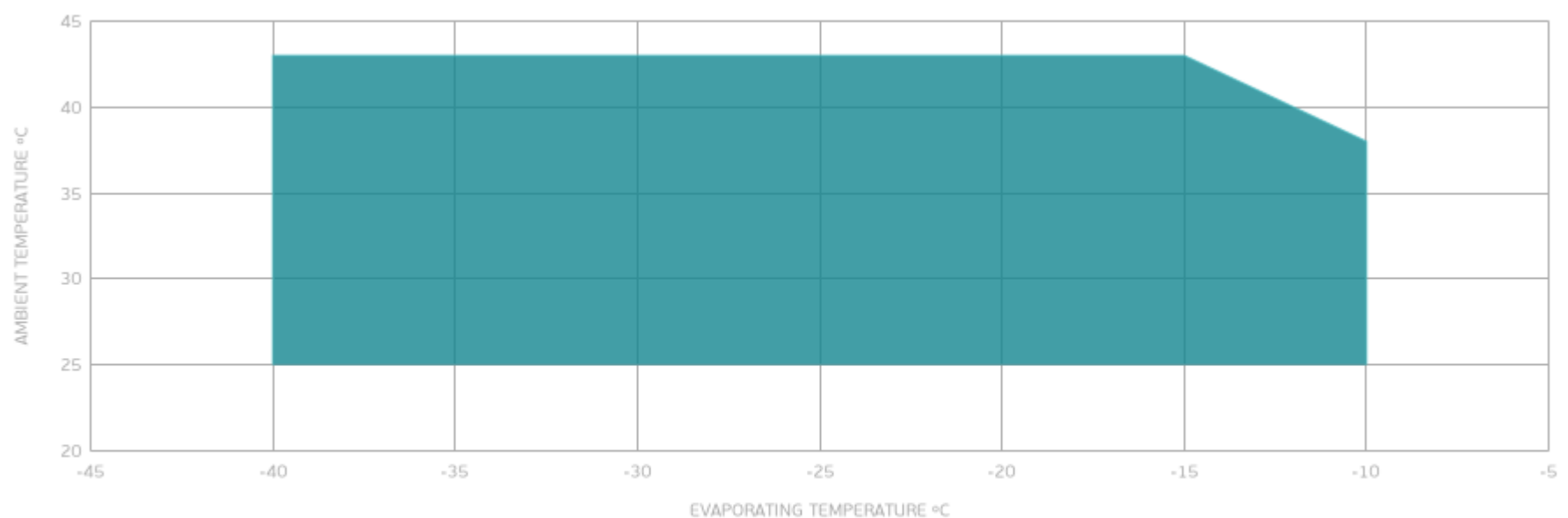

■ OPERATING CONDITION

EXTERNAL DIMENSIONS

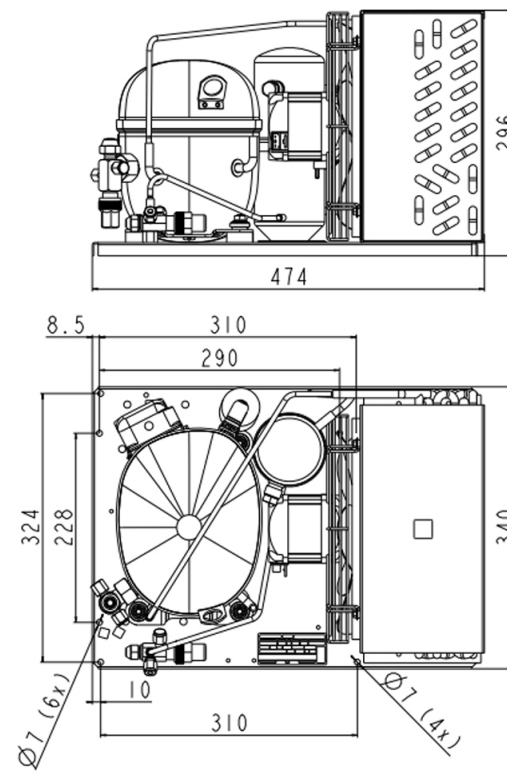

WIRING DIAGRAM

