

UNT2192GK

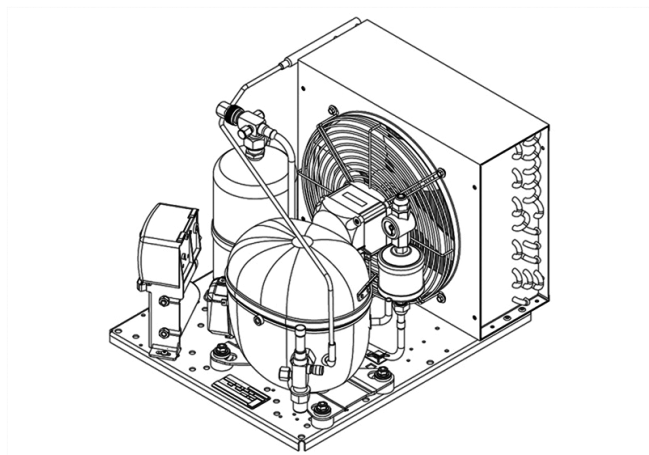

ENGINEERING CODE
503EA5212AA



POWER SUPPLY
220-240 V 50 Hz



MOTOR TYPE
CSIR



REFRIGERANT
R-452A



APPLICATION
LBP



STANDARD
EN13215_RG20



COOLING CAPACITY
583 W



EFFICIENCY
0.96 W/W

CE

ECODESIGN COMPLIANT

DATA

GENERAL DATA

Model UNT2192GK

ACCESSORIES

Discharge valve FLARE 3/8" 2110056

Suction valve FLARE 3/8" 2110024

CONDENSING COMPONENTS

Compressor NT2192GK LBP

Condenser 3R12T 2451218

Refrigerant R-404A

Expansion Device C-V

Fan Blade Diameter 275

Fankit 34W 275/31/5B 1996588

MECHANICAL DATA

Air Flow	800 m ³ /h
Height	323 mm
Receiver	2.3 L
Shaft Power	34
Weight	34 Kg
Width	395 mm
Length	494 mm

PERFORMANCE

TESTED CONDITIONS

Tested Refrigerant	R-452A
Tested Application	LBP
Tested Standard	EN13215_RG20

RATED POINTS

Ambient Temperature °C	Evaporating Temperature °C	Cooling Capacity W	Efficiency W/W	Consumo de Potencia W
32	-35	583	0.96	605

Test Condition: Subcooling 3 K, Return Gas 20 °C.

PERFORMANCE CURVE

Ambient Temperature 25°C

Evaporating Temperature °C	Cooling Capacity W	Efficiency W/W	Consumo de Potencia W
-40	513	1.01	510
-30	821	1.22	674
-25	1046	1.36	769
-20	1316	1.52	869
-15	1632	1.68	973
-10	1991	1.85	1078

Test Condition: Subcooling 3 K, Return Gas 20 °C.

PERFORMANCE CURVE

Ambient Temperature 32°C

Evaporating Temperature °C	Cooling Capacity W	Efficiency W/W	Consumo de Potencia W
-40	459	0.88	523
-30	749	1.08	696
-25	955	1.20	794
-20	1202	1.34	898
-15	1487	1.48	1005
-10	1810	1.63	1112

Test Condition: Subcooling 3 K, Return Gas 20 °C.

PERFORMANCE CURVE

Ambient Temperature 43°C

Evaporating Temperature °C	Cooling Capacity W	Efficiency W/W	Consumo de Potencia W
-40	401	0.78	512
-30	720	1.00	717
-25	927	1.12	830
-20	1164	1.23	947
-15	1431	1.34	1066

Test Condition: Subcooling 3 K, Return Gas 20 °C.

ENVELOPE

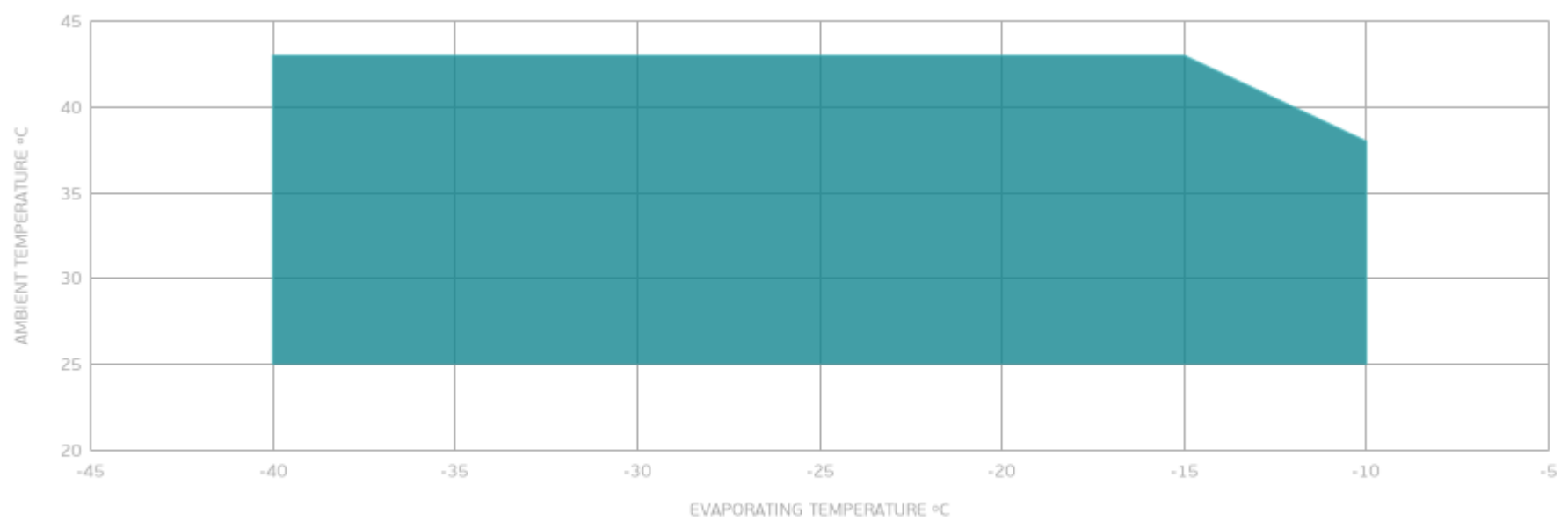

■ OPERATING CONDITION

EXTERNAL DIMENSIONS

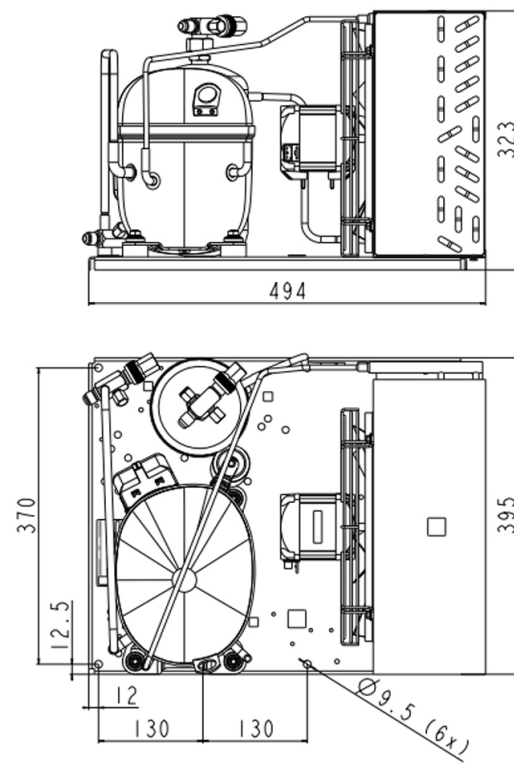

WIRING DIAGRAM

