

客户名称/Customer: _____

发行编号/NO. : CG20151025发行日期/DATE: 2015-10-22

全封闭型压缩机技术规格书

HERMETIC COMPRESSOR SPECIFICATION

机型/Model: **KSG280V1VMU**客户承认栏/Accept Marking:

本规格书从贵公司承认之日起生效，一式贰份。贵公司负责人承认签名之后请返回我公司一份，贵公司保留一份。

This document will be effective with your authorized signature. Please return one (1) copy of this form, and keep the other one (1) copy for your records.

浙江美芝压缩机有限公司

承认/Approved	担当/Drafted

适用范围 (Application)

压缩机型号 Model Name	KSG280V1VMU
压缩机类型 Compressor Type	全封闭型电动压缩机 Hermetic Motor Compressor
空调器类型 A/C Type	冷暖兼用型空调器 Cooling & Heating A/C System
冷媒类型 Refrigerant Type	R32
最大冷媒充注量 Maximal Refrigerant Charged	2.1 Kg Max
电机类型 Motor Type	单相诱导电机·运转电容型 Single Phase Induction Motor · PSC
电源类型 Power Source	单相 Single Phase 1ϕ-50HZ-220-240V
安全认证 Safety Approval	TUV: R 50296950

1、规格参数 (Specification)

汽缸容积 Displacement	27.85 cm³/rev.
冷冻机油充注量 Oil Charged	VG74 · 850 ml
总重量 (含冷冻机油) Weight (Oil Included)	20.5 Kg
电机极数 Pole Numbers	2 极/Poles
绕组阻值 (20°C时) Coil Resistance (at 20°C)	主绕组 辅绕组 Main: 1.26 \pm 5% Ω Aux. : 1.72 \pm 5% Ω
堵转电流 Locked Rotor Amps	(at 1 ϕ -50HZ-240V) \pm 10% 61 A
运转电容 Ruing Capacitor	65μF-400V
绝缘等级 Insulation Grade	E 级/Grade
排气管内径 I. D. of Discharge Pipe	9.8 mm
吸气管内径 I. D. of Suction Pipe	16.2 mm

2、额定性能规格 (Rated Performance Parameters)

额定能力 Rated Capacity	8650/8720	±5% W
额定输入功率 Rated Input Power	2050/2180	±5% W
额定输入电流 Rated Input Current	9.55/9.75	±5% A
能效比 % COP %	422/400	
噪音/NOISE (Sound Power Level)	★ 73	以下 MAX
振动 VIBRATION (切线方向振动实效值)	★ 15	以下 MAX
绝缘阻抗 Insulation Resistance	≥20 MΩ	封入氮气时 /Nitrogen Charged
绝缘耐压 Withstanding Voltage	AC1500V-1min	
残留水分量 Residual Moisture	冷凝法 ≤250mg	
含尘量 Residual Impurities	≤45mg	
接地阻抗 EARTHING RESISTANCE	0.1	以下 Ω MAX

*Remarks: Rated cop is measured by calorimeter methods of QMA-J50.016 made by Guangdong Meizhi Compressor Co., Ltd. Allowable cop should be more than 97% of the rated cop.

*备注: 额定 COP 根据本公司标准 QMA-J50.016 规定的卡路里方法测试, 允许 COP 应为额定 COP 的 97% 以上。

测定条件 (Rating Condition)

电源 Power Source	1φ-50HZ-220-240V	1φ-50HZ-220V
冷凝温度 Cond. Temp.	46.0°C	★46.0°C
蒸发温度 Evap. Temp.	10.0°C	★10.0°C
吸气温度 Return Gas Temp.	18.0°C	★18.0°C
过冷却温度 Liquid Temp.	41°C	
环境温度 Ambient Temp.	35°C	★20°C

3、电气配线接线图(Wire Connection Figure)

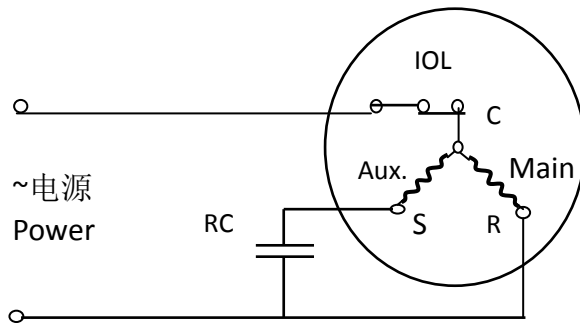

S: START (辅绕组 Aux Winding)

R: RUN (主绕组 Main Winding)

C: COMMON (共通)

RC: 运转电容 Run Capacitor

系统使用条件(Limit of System Application)

NO.	项目 Item	标准 (参考) Standard (reference)	极限状况下 Limit Cond.	说明 Note
1	排气压力 Discharge Pressure.	3.28 MPa	3.83 MPa	详细压力使用范围见附纸! See the attached chart of limitation of operation pressure.
2	吸气压力 Suction Pressure.	0.89 MPa	0.23~1.18 MPa	
3	压缩比 Compressing Ratio	8 Max	8 Max	
4	电机绕组温度 Motor Coil Temp.	100°C	125°C	
5	排气温度 Discharge Temp.	100°C	115°C	

注意事项 Application Notice:

- 整个运行过程中无液压缩发生。
No liquid refrigerant go back to compressor during the whole time.
- 连续运转时(包括除霜、除湿)压缩机底部温度-冷凝器中部温度需大于等于5°C以上;
When continuous running (include defrost and dehumidify), compressor bottom temp. subtract condensing temp. should be more than 5°C.
断续运转时压缩机底部温度-冷凝器中部温度需大于等于0°C以上。
When intermittent running, compressor bottom temp. subtract condensing temp. should be more than 0°C.
- 断续运转,每一周期5分钟以上,开2分钟以上,停2分钟以上。
When intermittent running, each cycle should be longer than 5 minutes. (On: over 2 min, Off: over 2 min)
- 运转电压波动允许范围 220V-15%~240V+10%(187~264V)
The supply voltage should be 220V-15%~240V+10%(187~264V)
- 高压侧和低压侧压力需保持平衡后才能启动。
Pressure should be balanced between high and low pressure side.
- 运转过程中不能有异常噪音发生。
In operation, abnormal noise is not allowed.
- 最大允许倾斜角度: 5°。

Tilt angle should be less than 5° .

8. 当压缩机以下状态时，需确认油面水平：

Oil level confirmation should be tested at:

1) 超负荷、低负荷时；

Overload and low load running;

2) 冷媒沉积启动时；

Refrigerant soaking starting;

3) 除霜开始、恢复时；

Defrost starting and resuming;

4) 超过最长配管时；

Connection pipe over 15m;

5) 超过最大落差时；

Elevation over 5m;

使用带视窗镜的压缩机进行确认；

Oil level confirmation test performed with side glass compressor:

1、在稳定运转状态（包括连续/断续运行），油面需在水平面 B 以上；

At steady running (include continuous or intermittent operation): oil level should be higher than B level.

2、在启动的 3 分钟以内，油面需在水平面 A 以上；

Within 3 minutes at starting: oil level should be higher than A level.

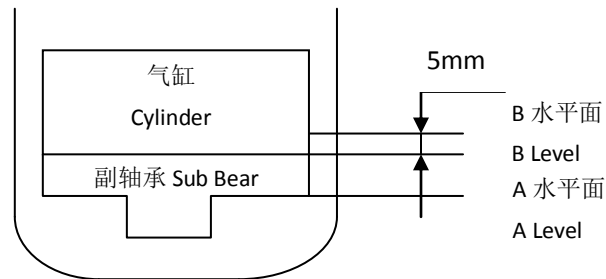

其他注意事项 Other Application Notice

1. 不要给吐出管、吸入管施加弯曲的力，强制其弯曲。
而且，对于始动、运转停止以及运输搬运等时所受冲击，配管设计时，各管许容应力如下：始动、停止时=30N/mm² 以下，运转时=20N/mm² 以下。
Don't provide any force on discharge & suction pipes. The piping stress should be less than 30N/mm² at starting & stopping, and less than 20N/mm² at running when designing the piping.
2. 压缩机不允许横置、倒置，在搬运时不允许跌落。
Do not put a compressor on its side or turn it over. And do not fall it off when moving.
3. 绝对不允许空气中运转。
COMPRESSING AIR IS NOT PERMITTED.
4. 压缩机密封塞拔除后，请尽快使用，不要将压缩机长时间放置。
Please assemble the compressor in your Air Conditioner rapidly after removing the plugs.
Don't place the compressor in air for a long time.
5. 电气品要使用弊社所指定的规格同等品。
Please use the accessories indicated by Our Company.
6. 冷媒量超过规定量时，需另行协商决定压缩机规格。（此时要考虑增加储液器、油加热器）
When the amount of refrigerant charged in the Air Conditioner is over the max amount allowable, compressor specification should be discussed. (Install additional accumulator, oil heater, etc.)
7. 冷媒填充原则上从高压侧开始实行。
Refrigerant must always be filled from the higher side of the refrigeration cycle.
8. 避免因误配线发生逆转。（若发生逆转，则压缩机不能再使用）
Avoiding compressor running in reverse caused by connecting electrical wire incorrectly.
(Don't reuse the compressor after running in reverse.)
9. 压缩机不得露天存放或存放在腐蚀性空气中如化学仓库等。
The compressor should be kept out of storing in open storage or corrosive atmosphere such as in a chemicals storage and so on.
10. 压缩机壳体表面不容许配线或类似物接触压缩机表面。
Do not allow electric cables or the like to touch compressor directly.
11. 必须有适当的防湿、防尘处理以防止水滴，灰尘进入压缩机
To avoid water droplets and dust into the compressor, moisture-proof or dust-proof measures must be take.
12. 分体式空调最长配管不超过 15m，配管的高低落差最大 5m。
For split type Air Conditioner, the maximum piping length should be 15m, and elevation difference should be within 5m.
13. 禁止使用 R410A 之外的冷媒。
Do not fill refrigeration cycles with other refrigerant except R410A.
14. 请不要裸手触摸运行中或刚停机正处于高温的压缩机，当心烫伤。
Do not touch the compressor with bare hands during operation or immediately after stoppage.
The compressor is at a high temperature. There is the danger of burns.
15. 维修保养设备时必须配戴防护眼镜。由于焊枪温度过高，拆卸配管时，当心会有冷媒、油的溅出而导致烫伤或进入眼中。
Wear safety goggles when servicing the unit. When removing the tubes by heating it with a burner, there is the danger of burns or eye injury if the refrigerant and/or oil remaining in the tubes is emitted.

R32 T1 GX工况 压缩机使用压力条件范围
LIMITATION OF OPERATION PRESSURE
FOR R32 TROPICAL MODEL

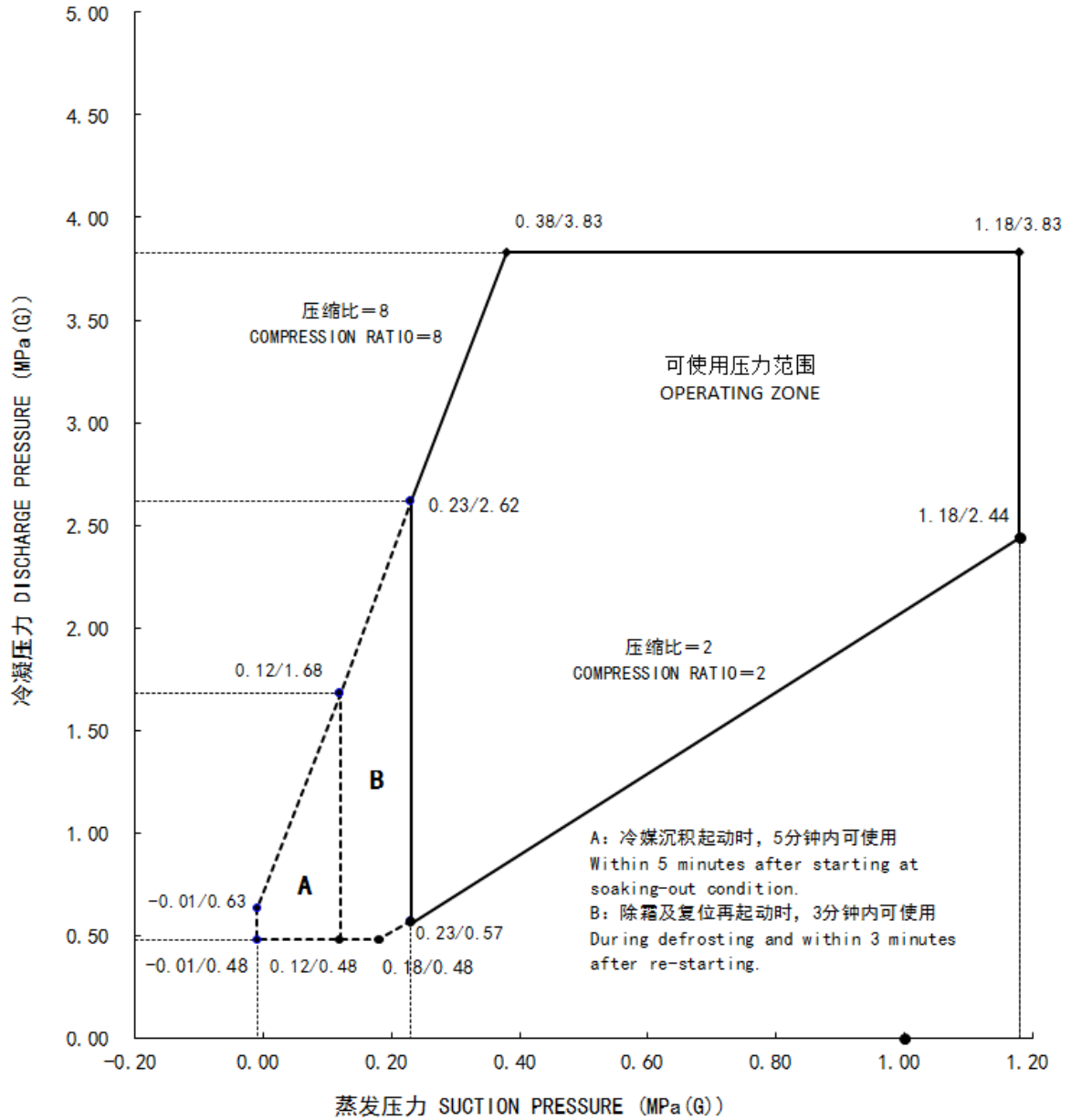

图纸/附件清单 Drawing/Accessories List

(See the Attached Pages)

名 称 (Parts Name)	数量 (Pieces)	图 号 (Drawing No.)	备注
电装品 ELE. COMPONENTS	1	MC357204Gr	
端子盖 TERMINAL COVER	1	MC33721410	
端子垫片 TERMINAL PACKING	1	MC33721710	
端子螺母 TERMINAL NUT	1	MC33300810	
橡胶垫 RUBBER CUSHION	3	MC61910110	
接地螺钉 EARTHING HEX BOLT	1	MC33300610	Note: GMCC Not Deliver; 客户自备。
接地螺钉垫片 WASHER FOR EARTHING BOLT	1	MC33300710	Note: GMCC Not Deliver; 客户自备。
压缩机外形图 COMPRESSOR DRAWING	1	MC618807GR	

电装品 (ELE. COMPONENTS)

ELE COMPONENTS

Drawing No. MC35720410

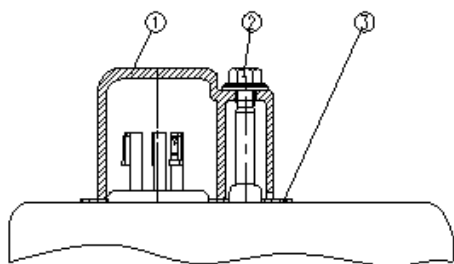
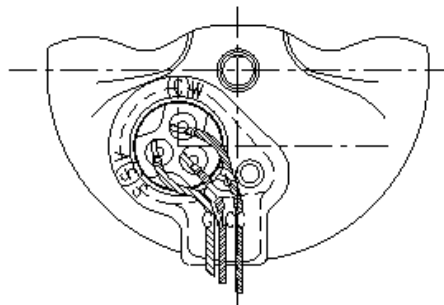
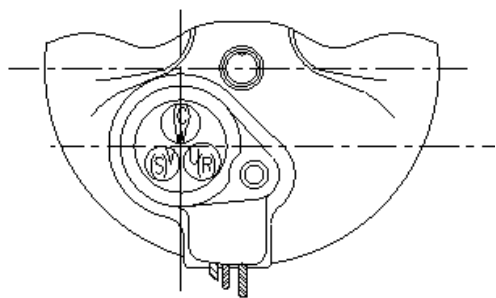

③	TERMINAL PACKING	MC33721710
②	TERMINAL NUT	MC33300810
①	TERMINAL COVER	MC33721410
Parts	T I T L E	Drawing No.

NOTES

Tightening totque of TERMINAL NUT : $1.2 \pm 0.2 \text{ N} \cdot \text{m}$

端子盖 (TERMINAL COVER)

TERMINAL COVER

Drawing No. MC33721410

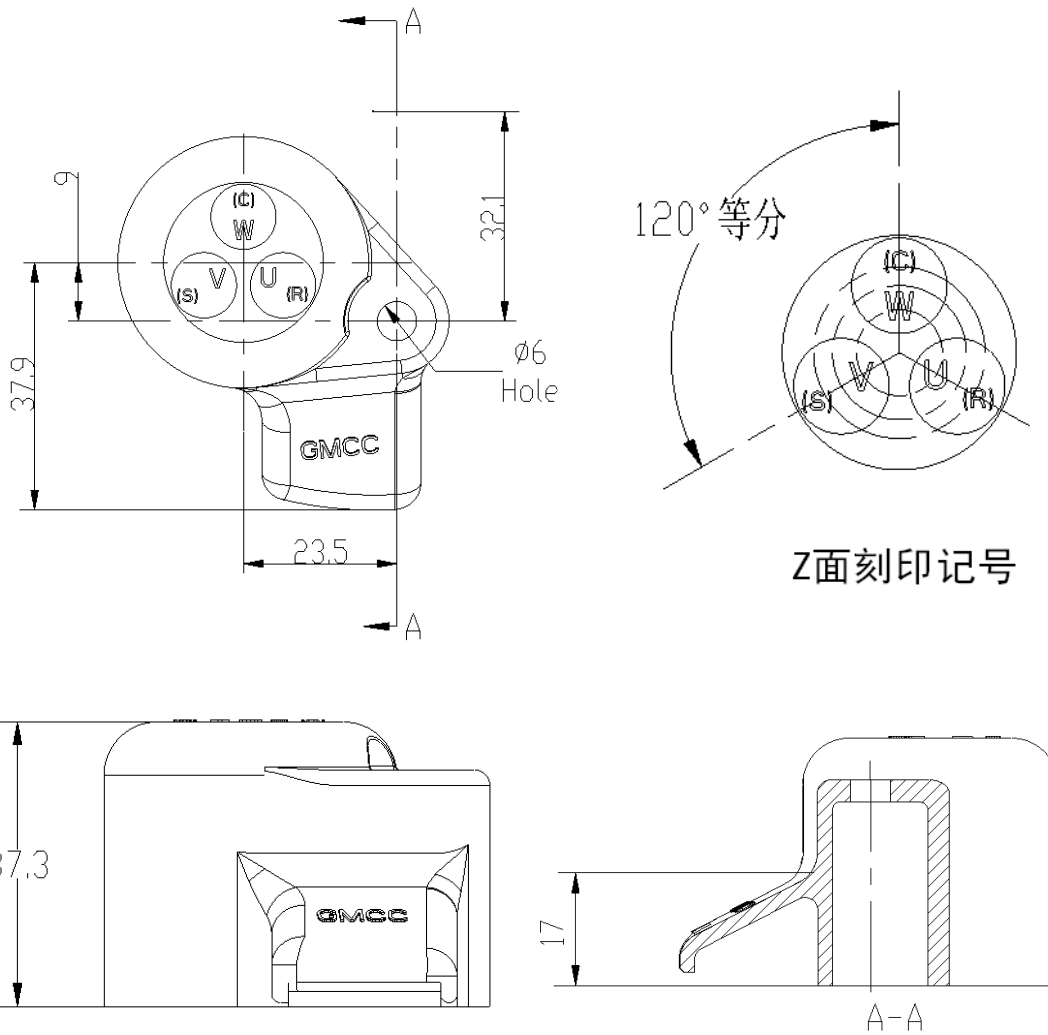

NOTES

MATERIAL: POLYBUTYLENE TEREPHTHALATE or BULK MOLDING COMPOUND

COLOR: BLACK

端子垫片 (TERMINAL PACKING)

TERMINAL PACKING

Drawing No.MC33721710

THICKNESS 1.2mm

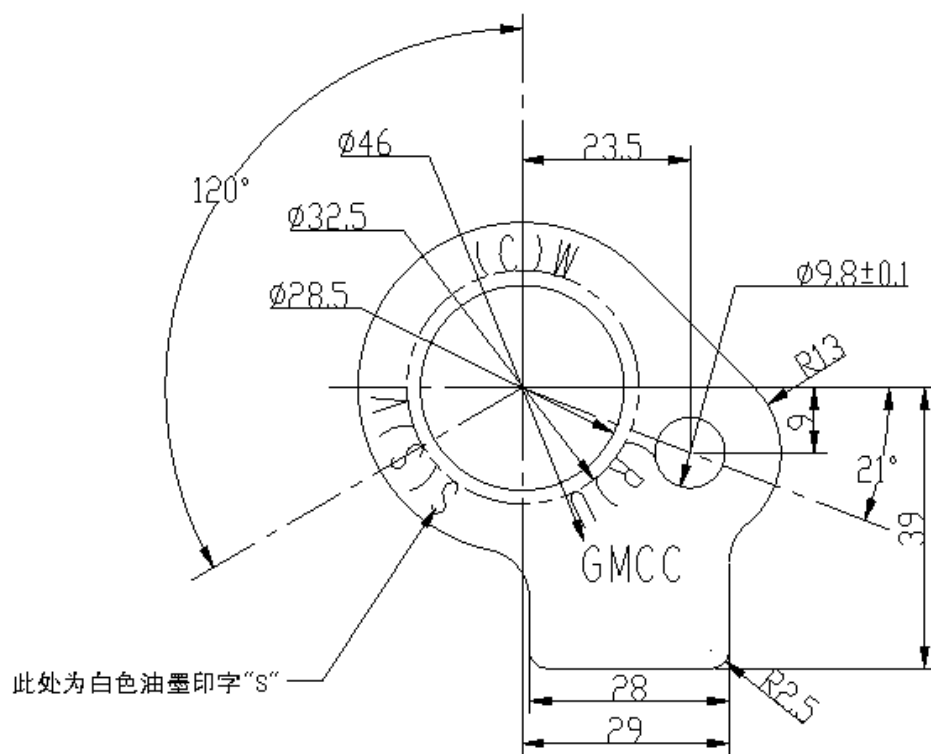

NOTES
 MATERIAL:SI
 COLOR:BLACK

端子螺母 (TERMINAL NUT)

TERMINAL NUT

Drawing No. MC33300810

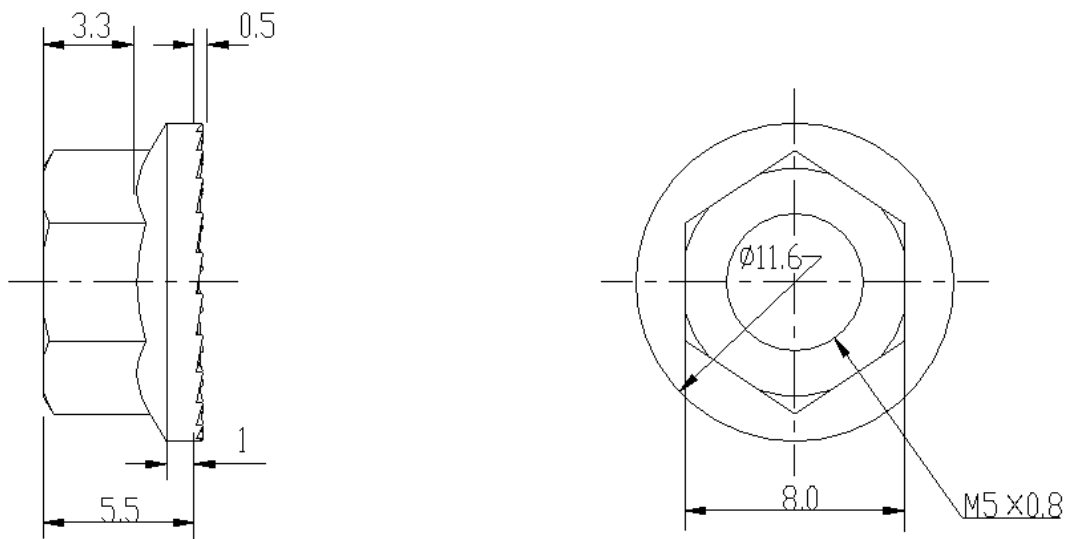

NOTES

MATERIAL: SWCH12A

TREATMENT: WITHOUT HEXAVALENT CHROMIUM COMPOUNDS (Ep-Fe/Zn 2-CM 2镀锌处理)

橡胶垫 (RUBBER CUSHION)

RUBBER CUSHION

Drawing: MC61910110

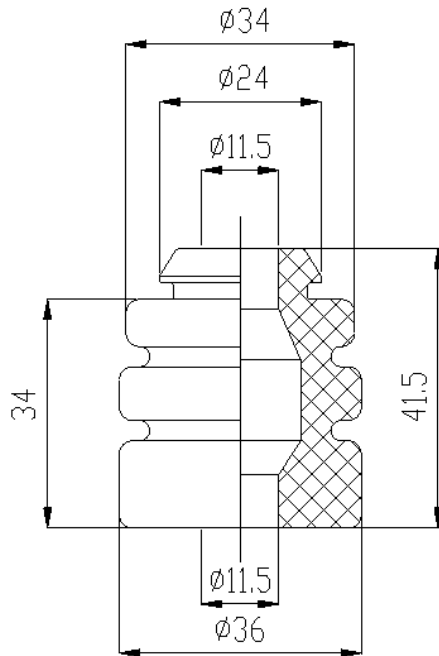
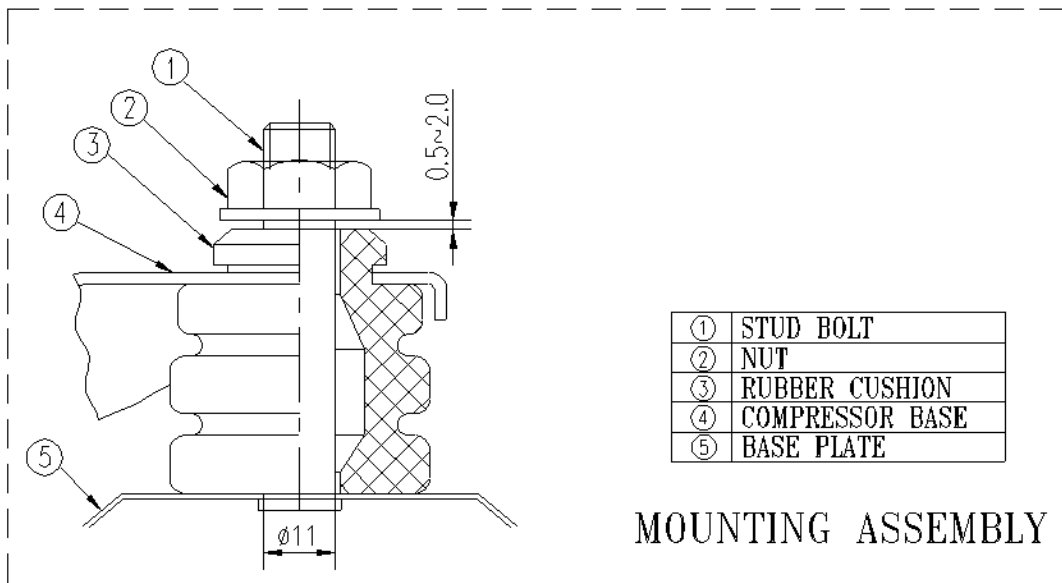
**NOTES****MATERIAL: EPDM****HARDNESS: HS=46 ± 5****MOUNTING ASSEMBLY**

外形图 (COMPRESSOR DRAWING)

RoHS																																																																																																																																																																																																																						
J9Z088193W 台架								 吸气管详细		 吸气管详细																																																																																																																																																																																																												
		<table border="1" style="width: 100%; border-collapse: collapse; height: 40px;"> <tr><td> </td><td> </td><td> </td><td> </td><td> </td><td> </td><td> </td><td> </td><td> </td><td> </td></tr> <tr><td> </td><td> </td><td> </td><td> </td><td> </td><td> </td><td> </td><td> </td><td> </td><td> </td></tr> <tr><td> </td><td> </td><td> </td><td> </td><td> </td><td> </td><td> </td><td> </td><td> </td><td> </td></tr> <tr><td> </td><td> </td><td> </td><td> </td><td> </td><td> </td><td> </td><td> </td><td> </td><td> </td></tr> <tr><td> </td><td> </td><td> </td><td> </td><td> </td><td> </td><td> </td><td> </td><td> </td><td> </td></tr> <tr> <td>KSG280V1VMU</td> <td>340</td> <td>313</td> <td>80</td> <td>330</td> <td>60</td> <td>122</td> <td>9.8</td> <td>16.2</td> <td>15.10.20</td> </tr> <tr> <td>机种名</td> <td>A</td> <td>B</td> <td>D</td> <td>E</td> <td>F</td> <td>H</td> <td>D1</td> <td>D2</td> <td>年月日</td> </tr> </table>																																																										KSG280V1VMU	340	313	80	330	60	122	9.8	16.2	15.10.20	机种名	A	B	D	E	F	H	D1	D2	年月日																																																																																																																																							
KSG280V1VMU	340	313	80	330	60	122	9.8	16.2	15.10.20																																																																																																																																																																																																													
机种名	A	B	D	E	F	H	D1	D2	年月日																																																																																																																																																																																																													
<table border="1" style="width: 100%; border-collapse: collapse; height: 40px;"> <tr><td> </td><td> </td><td> </td><td> </td><td> </td><td> </td><td> </td><td> </td><td> </td><td> </td></tr> <tr><td> </td><td> </td><td> </td><td> </td><td> </td><td> </td><td> </td><td> </td><td> </td><td> </td></tr> <tr><td> </td><td> </td><td> </td><td> </td><td> </td><td> </td><td> </td><td> </td><td> </td><td> </td></tr> <tr><td> </td><td> </td><td> </td><td> </td><td> </td><td> </td><td> </td><td> </td><td> </td><td> </td></tr> <tr> <td>标记</td> <td>数量</td> <td>更改文件号</td> <td>签字</td> <td>日期</td> <td> </td> <td> </td> <td> </td> <td> </td> <td> </td> </tr> </table>																																										标记	数量	更改文件号	签字	日期						<table border="1" style="width: 100%; border-collapse: collapse;"> <tr> <td>设计</td> <td>工艺</td> <td colspan="3">材料</td> <td colspan="2">图号</td> <td colspan="2">Gr</td> <td colspan="2">10</td> </tr> <tr> <td>制图</td> <td>标准化</td> <td colspan="3"> </td> <td colspan="2">MC618807Gr</td> <td colspan="2">名称</td> <td colspan="2">外形图</td> </tr> <tr> <td>校对</td> <td>审定</td> <td colspan="3"> </td> <td colspan="2"> </td> <td colspan="2"> </td> <td colspan="2">压缩机事业部</td> </tr> <tr> <td>审核</td> <td>日期</td> <td colspan="3"> </td> <td colspan="2"> </td> <td colspan="2"> </td> <td colspan="2"> </td> </tr> <tr> <td colspan="2">201510201610</td> <td colspan="3"> </td> <td colspan="2"> </td> <td colspan="2"> </td> <td colspan="2"> </td> </tr> </table>						设计	工艺	材料			图号		Gr		10		制图	标准化				MC618807Gr		名称		外形图		校对	审定								压缩机事业部		审核	日期										201510201610											<table border="1" style="width: 100%; border-collapse: collapse;"> <tr> <td> </td> <td> </td> <td> </td> <td> </td> <td> </td> <td> </td> <td> </td> <td> </td> <td> </td> <td> </td> </tr> <tr> <td> </td> <td> </td> <td> </td> <td> </td> <td> </td> <td> </td> <td> </td> <td> </td> <td> </td> <td> </td> </tr> <tr> <td> </td> <td> </td> <td> </td> <td> </td> <td> </td> <td> </td> <td> </td> <td> </td> <td> </td> <td> </td> </tr> <tr> <td> </td> <td> </td> <td> </td> <td> </td> <td> </td> <td> </td> <td> </td> <td> </td> <td> </td> <td> </td> </tr> <tr> <td> </td> <td> </td> <td> </td> <td> </td> <td> </td> <td> </td> <td> </td> <td> </td> <td> </td> <td> </td> </tr> <tr> <td> </td> <td> </td> <td> </td> <td> </td> <td> </td> <td> </td> <td> </td> <td> </td> <td> </td> <td> </td> </tr> <tr> <td> </td> <td> </td> <td> </td> <td> </td> <td> </td> <td> </td> <td> </td> <td> </td> <td> </td> <td> </td> </tr> <tr> <td> </td> <td> </td> <td> </td> <td> </td> <td> </td> <td> </td> <td> </td> <td> </td> <td> </td> <td> </td> </tr> <tr> <td> </td> <td> </td> <td> </td> <td> </td> <td> </td> <td> </td> <td> </td> <td> </td> <td> </td> <td> </td> </tr> <tr> <td> </td> <td> </td> <td> </td> <td> </td> <td> </td> <td> </td> <td> </td> <td> </td> <td> </td> <td> </td> </tr> </table>																																																																																																					
标记	数量	更改文件号	签字	日期																																																																																																																																																																																																																		
设计	工艺	材料			图号		Gr		10																																																																																																																																																																																																													
制图	标准化				MC618807Gr		名称		外形图																																																																																																																																																																																																													
校对	审定								压缩机事业部																																																																																																																																																																																																													
审核	日期																																																																																																																																																																																																																					
201510201610																																																																																																																																																																																																																						

