

R11_-4030_-4T2-3830

Diameter:

400 mm

Nominal data according to standard EN 60335:

Phase	3~
Nominal voltage	400 V
Frequency	50 Hz
Speed	high/low
Rated power input	195/130 W
Rated current	0.34/0.21 A
Rated speed	1320/1000 RPM
Min. ambient temperature	-30 °C
Max. ambient temperature	70/70 °C
Sound power level A weighted	73/66 dB (A)
Connection	terminal box
Insulation class	155
Protection class	IP54

ErP data according to EU regulation 327/2011:

Overall efficiency	31.3 %
Measurement category	A
Efficiency category	static
Efficiency grade N	41.8
Variable speed drive	NO
Power input	218 W
Air flow	2840 m³/h
Pressure drop	90 Pa
Speed	1332 RPM
Specific ratio	1.00

Aerodynamic characteristic

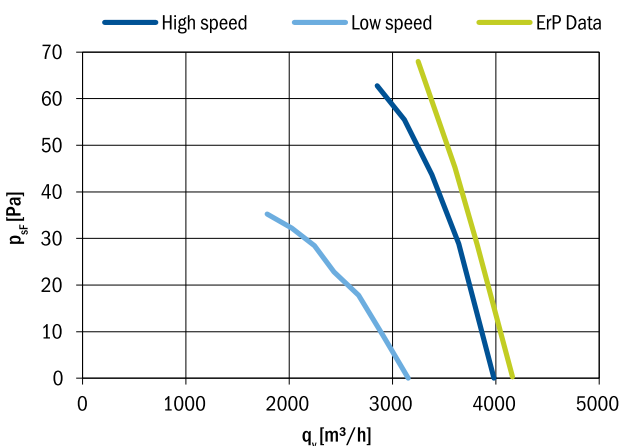

Fan characteristic measured in short bell mouth with guard grill.
ErP characteristic measured in full bell mouth without guard grill.

General notes

Connection diagrams:		
Sucking	0301-1-0048	See section
Blowing	0301-1-0048	Connection diagrams
Guard grills & wall-plates	See section Accessories	
Standards compliance	See introduction page	



Fan with guard grill

Airflow Direction	Type	Code	Weight (kg)
Sucking	R11R-4030A-4T2-3830	0311-4-0034	5.7
Blowing	R11R-4030P-4T2-3830	0311-4-0042	

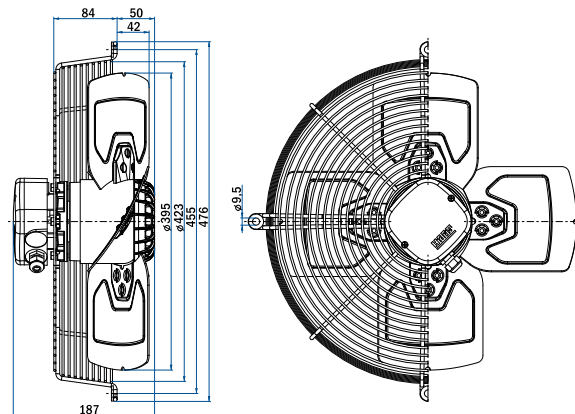

Fan with plate

Airflow Direction	Type	Code	Weight (kg)
Sucking	R11P-4030A-4T2-3830	On request	
Blowing	R11P-4030P-4T2-3830	On request	

Fan without guard grill

Airflow Direction	Type	Code	Weight (kg)
Sucking	R11E-4030A-4T2-3830	On request	
Blowing	R11E-4030P-4T2-3830	On request	