

Vsak prenos tretjim osebam in uporaba v nedogovorjene namene ni dovoljen. This document must not be copied without our written permission and/or transferred to a third party for any unauthorized purpose.

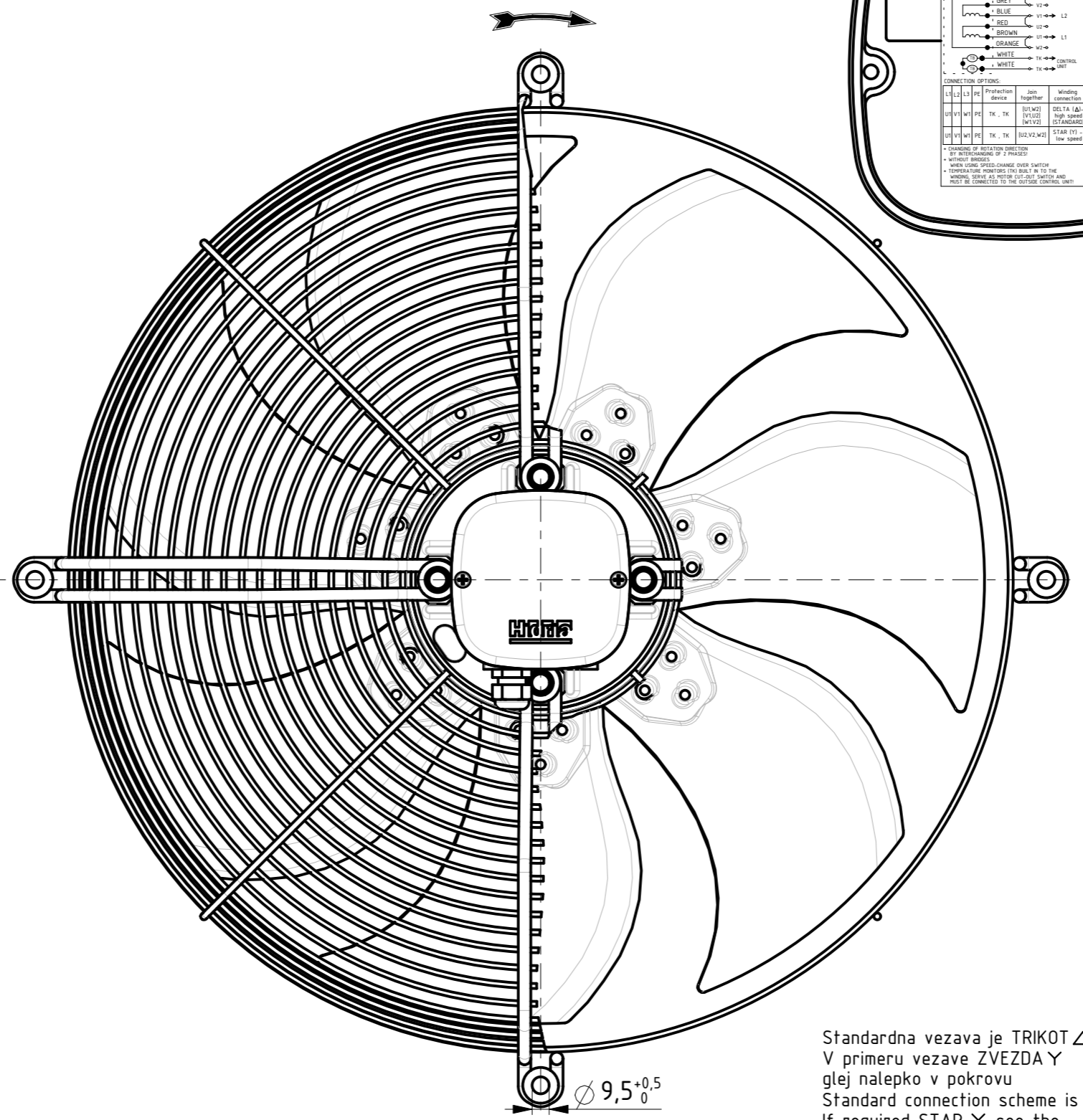

Standardna vezava je TRIKOT Δ
V primeru vezave ZVEZDA Y
glej nalepko v pokrovu
Standard connection scheme is DELTA Δ
If required STAR Y see the
connection diagram in the cover

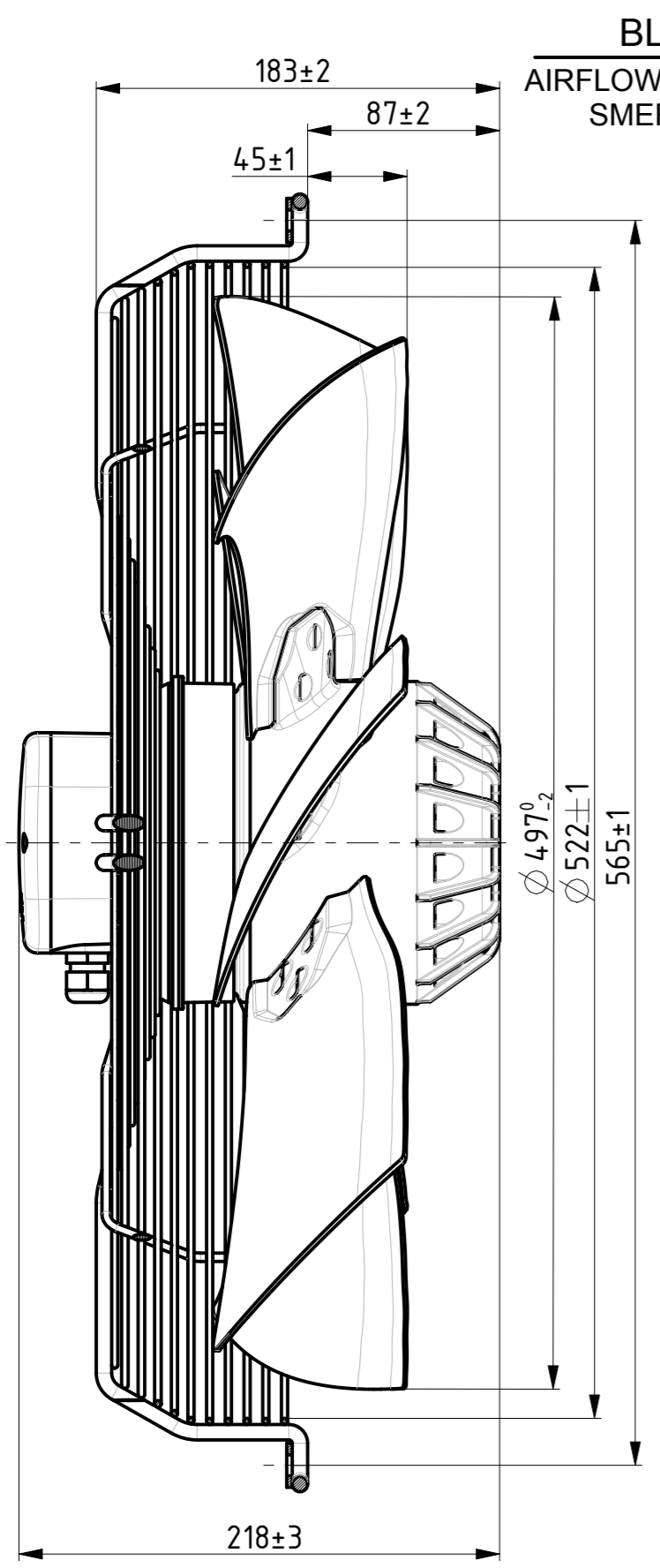
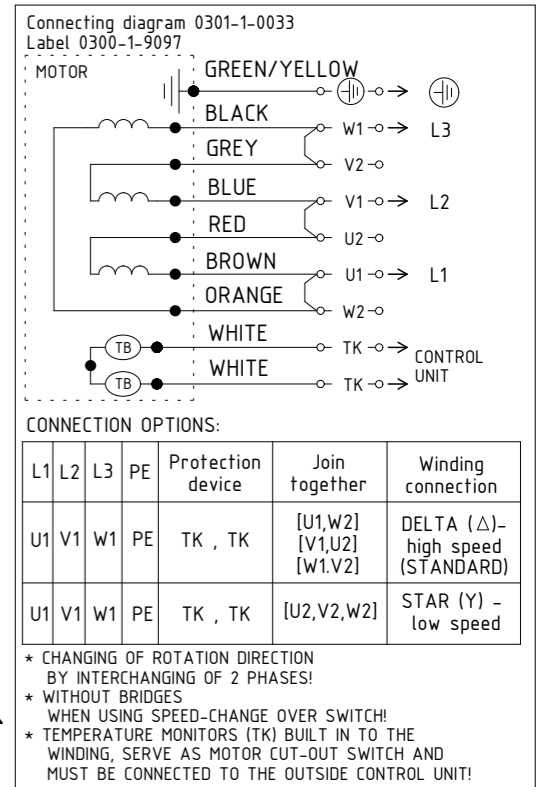
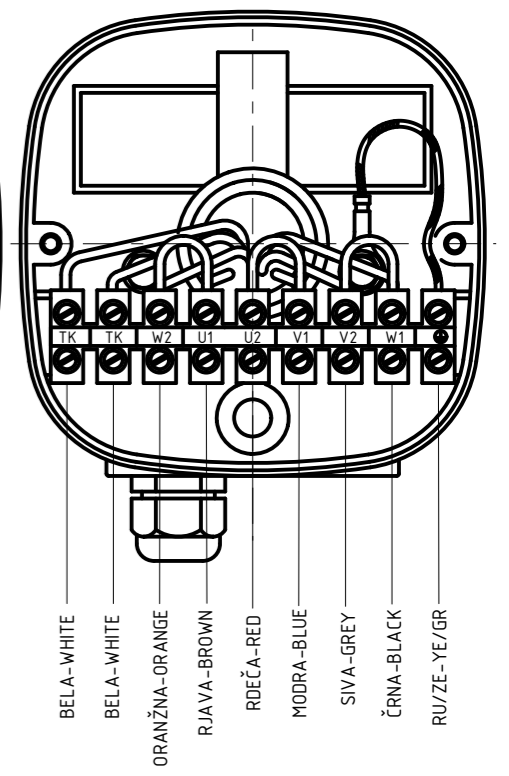
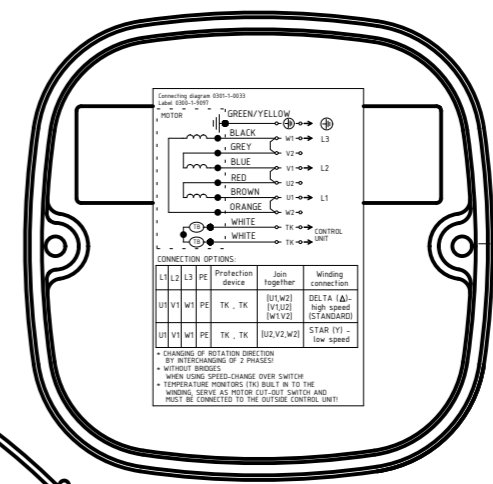

Opomba:
Vzmetna ploščica na kabelski strani.
- navodilo za kontrolo ventilatorja 0301-1-4506
- checking instruction 0301-1-4506

Horia MADE IN SLOVENIA **CE** DATE

R13R-5030HP-4T2-7056 0313-4-1145
 3~400V 50Hz D/Y 630/480W 1,75/0,85A 1415/1260RPM
 MAX.AMB.45° C IP54 INS.CL.155
 TH.PROT. ROT.

ErP: Effes=31,0% (A,static) N=37,8

Horia		NETOLERIRANE MERE UNTOLERANCED DIM.	ISO 2768-m	MERIL/FORMAT 33:100 / A3	
Izdano		POVRSINSKA OBD. SURFACE TEXTURE		MATERIAL	
		RISAL	DATUM 13-Avg-2010	PODPIS Uroš K.	NAZIV: TITILE: VENTILATOR HEF R13R-5030HP-4T2-7056
		PROJEKTIRAL	13-Avg-2010	Uroš T.	
		POTRIL ROTMATIKA MOTORS			
		POTRIL SPE LAMELLE			
		POTRIL ROTMATIKA FANS			
		POTRIL			
3	321/12	14-Dec-2012	Uroš K.		
2	235/10	26-Avg-2010	Uroš K.		
1	226/10	13-Avg-2010	Uroš T.		
ST.	ST.SPR.	DATUM	PODPIS		
				KODA: CODE: 0313-4-1145 0313-4-1145	VERZIJA: REV: AB
					LIST: SHEET: 1 OD: OF: 1