

Diameter:

630 mm

R14_-63AP_-ET80B-14B17



Nominal data according to standard IEC 60034 (max. load):	
Phase	3~
Nominal voltage	400 V
Nominal voltage range	380-480 V
Frequency	50-60 Hz
Input power	900 W
Input current	1.57 A
Nominal speed	1100 RPM
Min. ambient temperature	-25 °C
Protection class	IP54
Insulation class	130

ErP data according to EU regulation 327/2011:	
Overall efficiency	52.4 %
Measurement category	A
Efficiency category	static
Efficiency grade N	53.1
Variable speed drive	INTEGRATED
Power input	0.88 kW
Air flow	9846 m ³ /h
Pressure drop	160 Pa
Rotational speed	1112 RPM
Specific ratio	1.00

General notes	
Connection diagram: 0302-0-1006	See section Connection diagrams
Guard grills & wall-plates	See section Accessories
Standards compliance	See introduction page

Dimensions and fan ordering information



Type: R14R-63APS-ET80B-14B17
Code: 0314-4-0051
Weight: 16.1 kg

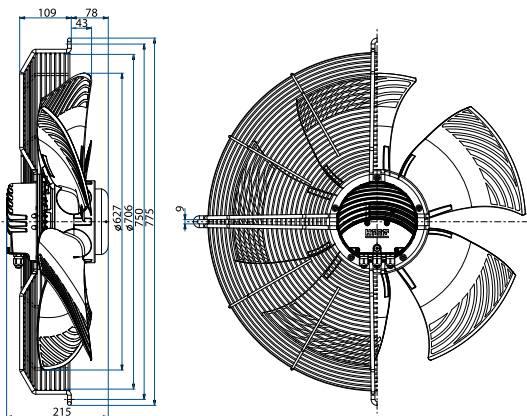

Type: R14P-63APS-ET80B-14B17
Code: 0314-4-0052
Weight: 24.4 kg

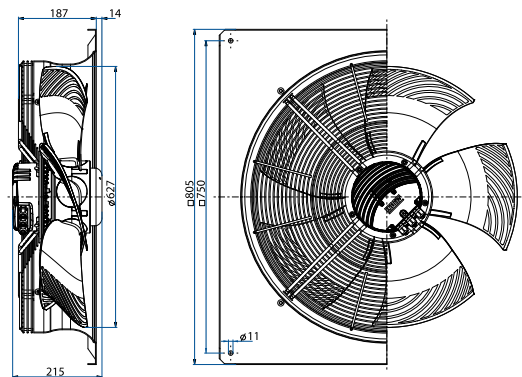

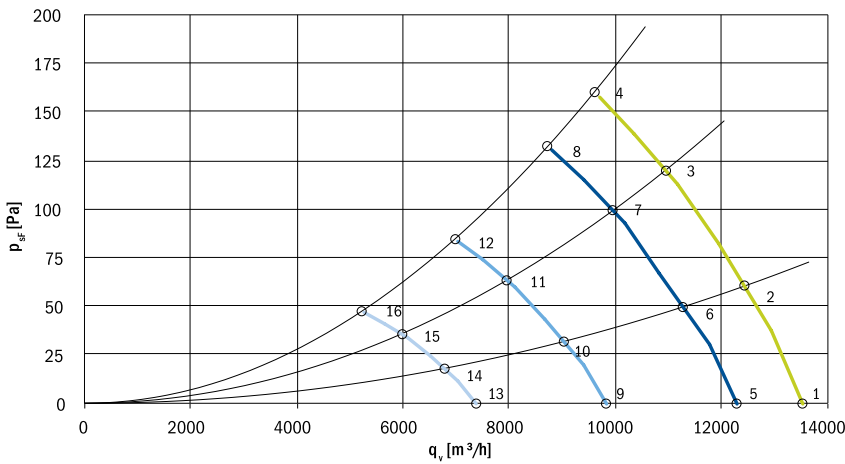

Aerodynamic characteristic:

- measured in full bell mouth without guard grill
- instalation category A according to ISO 5801

Sound power level:

- measured on pressure side
- fan mounted in full bell mouth without guard grill
- measured according to ISO 3741; instalation type A

The values given may vary according to actual instalation in the unit.

Definition of symbols

- U [V]** Supply voltage
- f [Hz]** Frequency
- n [RPM]** Fan speed
- qv [m³/h]** Air flow
- psF [Pa]** Pressure drop
- Pe [W]** Power input
- I [A]** Current
- Lwa [dB (A)]** Sound power level A weighted
- Ta max [°C]** Max. ambient temperature

	U [V]	f [Hz]	n [RPM]	qv [m³/h]	psF [Pa]	Pe [W]	I [A]	Lwa out [dB (A)]	Ta max [°C]
1	400	50	1110	13530	0	640	1.37	74	60
2	400	50	1110	12400	60	730	1.53	71	60
3	400	50	1110	10950	120	838	1.75	72	60
4	400	50	1110	9600	160	900	1.88	73	60
5	400	50	1000	12300	0	482	1.03	72	60
6	400	50	1000	11300	50	545	1.15	69	60
7	400	50	1000	9950	100	630	1.31	70	60
8	400	50	1000	8800	130	677	1.42	71	60
9	400	50	800	9840	0	247	0.53	67	60
10	400	50	800	9030	32	280	0.59	64	60
11	400	50	800	8000	63	322	0.67	65	60
12	400	50	800	7020	83	345	0.73	66	60
13	400	50	600	7380	0	104	0.22	61	60
14	400	50	600	6800	17	118	0.25	58	60
15	400	50	600	6000	35	135	0.28	59	60
16	400	50	600	5280	48	145	0.30	60	60



Type: R14R-63APB-ET80B-14B17
Code: 0314-4-0053
Weight: 16.4 kg

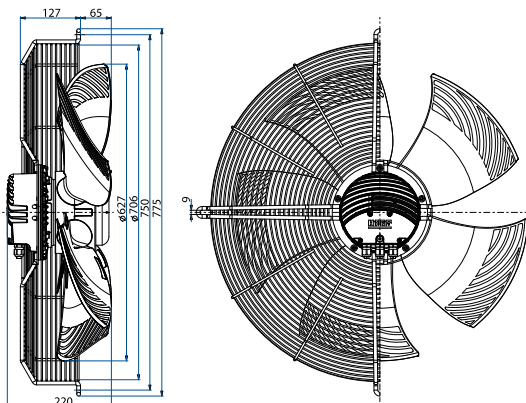

Type: R14P-63APB-ET80B-14B17
Code: 0314-4-0054
Weight: 24.6 kg

