

AXIAL FAN

Unit:axial fan

Type:

Motor:single phase motor with capacitor

Customer:

Motor type:MTA502RF

Customer type:

Type	Voltage V	Frequency Hz	Input power W	Current A	Speed r/min $\pm 5\%$	Air volume m ³ /h	Noise level dBA	Capacitor μ F/VDB
MTA502RF	220	50	80	0.4	950	1700	56	3 μ F/450V

Insulation class : B

Operating type: S1

Permissible ambient temperature : -30~60°C

Temperature increase: $\Delta T \leq 85k$

Motor protection:thermocontact 150 \pm 5°C

Bearings: ball bearings

License: CE

Model meanings:

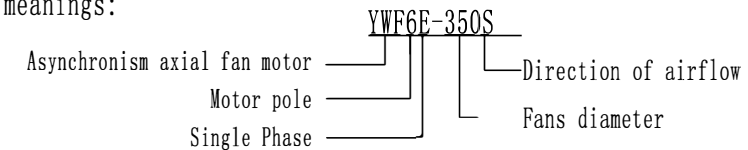

Electrical connection:lead wire 0.50mm

Direction of rotation:clockwise(sucking),Airflow direction:"S" looking at rotor side

High-voltage test according to EN 60335-1 1800V

Material/Surface treatment:rotor with condensation drain holes varnished black,stator temperature protected

Balance grade:G6.3 Fan balanced dynamically in two planes

APPROX. WEIGHT

MEANS

DRN. BY

CHD. BY

ENG. BY

APP. BY

A4

SCALE

SHEET: of

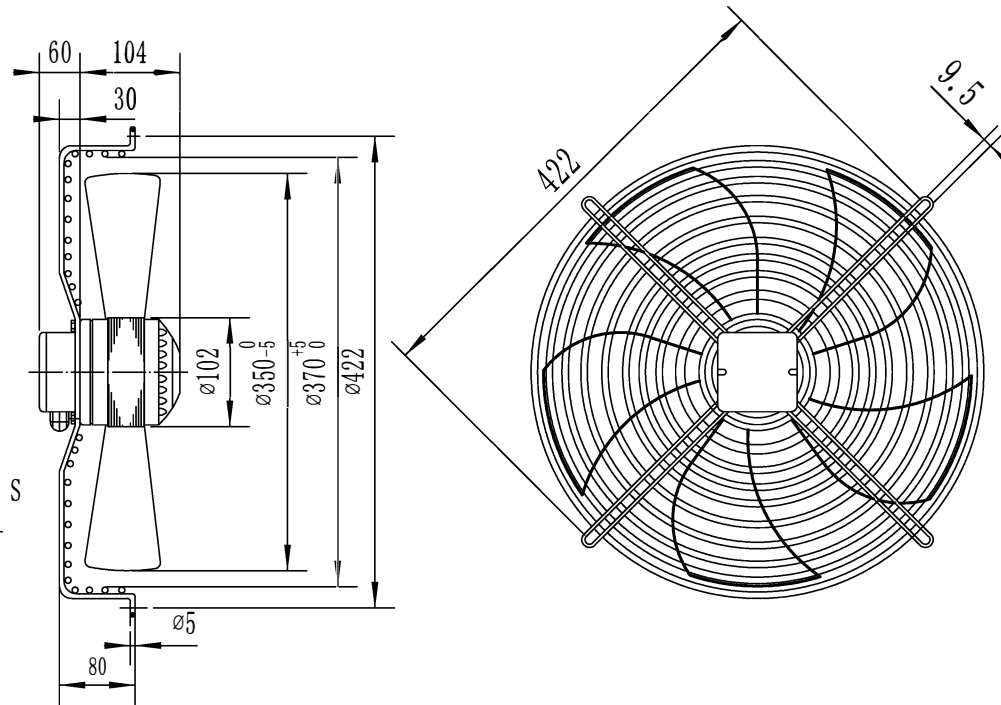

MTA502RF AXIAL FAN MOTOR

220V 50Hz 0.4A 80W

3 μ F/450V 950r/min CL. B



SINGLE-PHASE WIRING DIAGRAM

