

SPECIFICATIONS OF COMPRESSOR

Model No: 5CB110SA04

Output : 10 HP



Temporary

Panasonic Appliances Compressor (Dalian) Co., Ltd.

Section 1. General Specifications

Content		Unit	Specification
Compressor Model (Code)		—	5CB110SA04
Type		—	Hermetic Scroll Compressor
Application		—	High Back Pressure
Evap. Temp. Range		°C (°F)	-15~12 (5~54)
Compressor Cooling Type		—	Natural Cooling
Power Source	Phase	—	3
	Rated Voltage	V	380~415
	Rated Frequency	Hz	50
Voltage Range		V	342~456
Weight (Including Oil)		kg	44.6
Refrigerant		—	R410A
Oil Type		—	FV68S
Oil Charge		ml	2500
Displacement		cm ³ /rev	110.2
MCC		A	24.0
Motor	Motor Type	—	3-PH Induction Motor
	Number of Poles	—	2
	Electrical Insulation	Class	E
	Nominal Revolution	min ⁻¹	—
	Locked Rotor Ampere	A	99
	Winding Resistance [at 25°C (77°F)]	Ω	U-V
U-W			1.382
V-W			1.339
Connection Tube	Suction Line (O.D.)	mm (in)	25.4 (1.0)
	Discharge Line (O.D.)	mm (in)	19.05 (0.750)
Compressor Surface Paint		—	Black Paint

Notes

- 1 Voltage range is applied at standard rating conditions.
- 2 Motor specifications in the table are the average values for your reference.
- 3 () : All units with parentheses are reference values.

Expiration of Specification

Expiration of this specification shall be effected until issuing a notice with indication of the expiration date from the issued date . In case of improvement or elimination of this specification , it shall be handled by the revision record based on agreement between both sides.

Section 2. Performance Warranty

2.1 Performance

Power Source (3PH)	Hz	50
	V	380
Capacity	W	27,400
	(BTU/hr)	93,489
Input Power	W	8,980
Current	A	15.7

Standard Rating Conditions

Refrigerant	—	R410A
Condensing Temp.	°C (°F)	54.5 (130.1)
Evaporating Temp.	°C (°F)	7 (44.6)
Suction Gas Temp.	°C (°F)	18.5 (65.3)
Liquid Temp.	°C (°F)	46.0 (114.8)
Ambient Temp.	°C (°F)	35 (95)

2.2 Sound Level

Power Source (3PH)	Hz	50
	V	380
Sound Level	dB (A)	69Max.

Notes

- 1 The operating conditions are the same as 2.1.
- 2 MIC location is the distance of 1m (3.28feet) from the compressor.
- 3 Sound Level is an average sound pressure level in four directions.

2.3 Minimum Starting Voltage

Power Source (3PH)	Hz	50
Minimum Starting Voltage	V	323

Conditions

Compressor Temp.	°C (°F)	10~60 (50~140)
Ambient Temp.	°C (°F)	10~40 (50~105)
High Pressure	MPa(G) (psig)	3.25 (471.4)
Low Pressure	MPa(G) (psig)	0.9 (130.5)

2.4 Others

Content		Unit	Specification
Design Pressure	L.P. S.	MPa(G) (psig)	2.21 (320.5)
	H. P. S.	MPa(G) (psig)	4.15 (601.9)
Insulation Resistance		MΩ	100 (without refrigerant)
Dielectric Strength (The leakage current is less than 10mA)		V	1900 (1 minute)
Residual Moisture (MAX)		mg	300

Note:

1. The insulation resistance be measured with a DC500V megohm tester.

Section 3. Standard Accessories

3.1 Accessories List

Parts Name	Qty	Parts code	Revision No.	Note
Terminal Box Cover	1	A-0101-DSB	0	Installed on Compressor
Terminal Box Clip	1	A-0201-DSB	0	Installed on Compressor
Eyelet Rub Lead Wire	1	A-0301-DSB	0	Installed on Compressor
Mounting Grommet	4	M-0101-DSC	0	
Mounting Sleeve	4	M-0202-DSC	0	
Screw Special	1	B-0101-DSB	0	Installed on Compressor

3.2 The Drawing for Reference

Parts Name	Parts Code	Revision No.
Compressor Outline Drawing	D-0105-DSB	0
Mounting Parts Listing	M-5102-DSC	0
Packing Dimensions	D-0203-DSB	0
Wiring Diagram	E-0910-DSB	0

3.3 Internal Motor Protector (in compressor)

Parts Name	Specification	
Internal Motor Protector	Type of protector	UP28NA08B-560
	Trip Temperature	135±5℃
	Reset Temperature	70±10℃
	Trip Current	78A 3~10s

1. When the protector is not on current, the ambient temperature of the protector rises to the temperature of protector which is for touching current and off, this is operating temperature. Then, the ambient temperature of the protector goes down the moment it touches current and closes, at this moment, the temperature of the protector is recovery temperature.
2. When the current of compressor is overloaded, under the ambient temperature 25℃, the protector can guarantee the motion in the limited current within the first operating circles 3-10seconds.

Section 4. Compressor Protection

4.1 Protection Required but not Included with compressor

Protection Device	Items	Specifications
Reversal Defensible Relay	Features	To protect the compressor from reverse rotation
	Rated Voltage	AC380V
Crankcase Heater	Rated Power	44 Watts
Discharge Thermostat	Mounting Position	Located within 100mm(4 in)from the compressor shell
	Trip Temperature	130±5°C
	Reset Temperature	95±11°C
High Pressure Switch	Setting	Cut-out seting no higher than 4.15MPa (G) (601.9 psig)
Low Pressure Switch	Setting	Cut-out seting no lower than 0.15MPa (G) (21.8 psig)

4.2 Position of the Protection and Refrigerant Charging

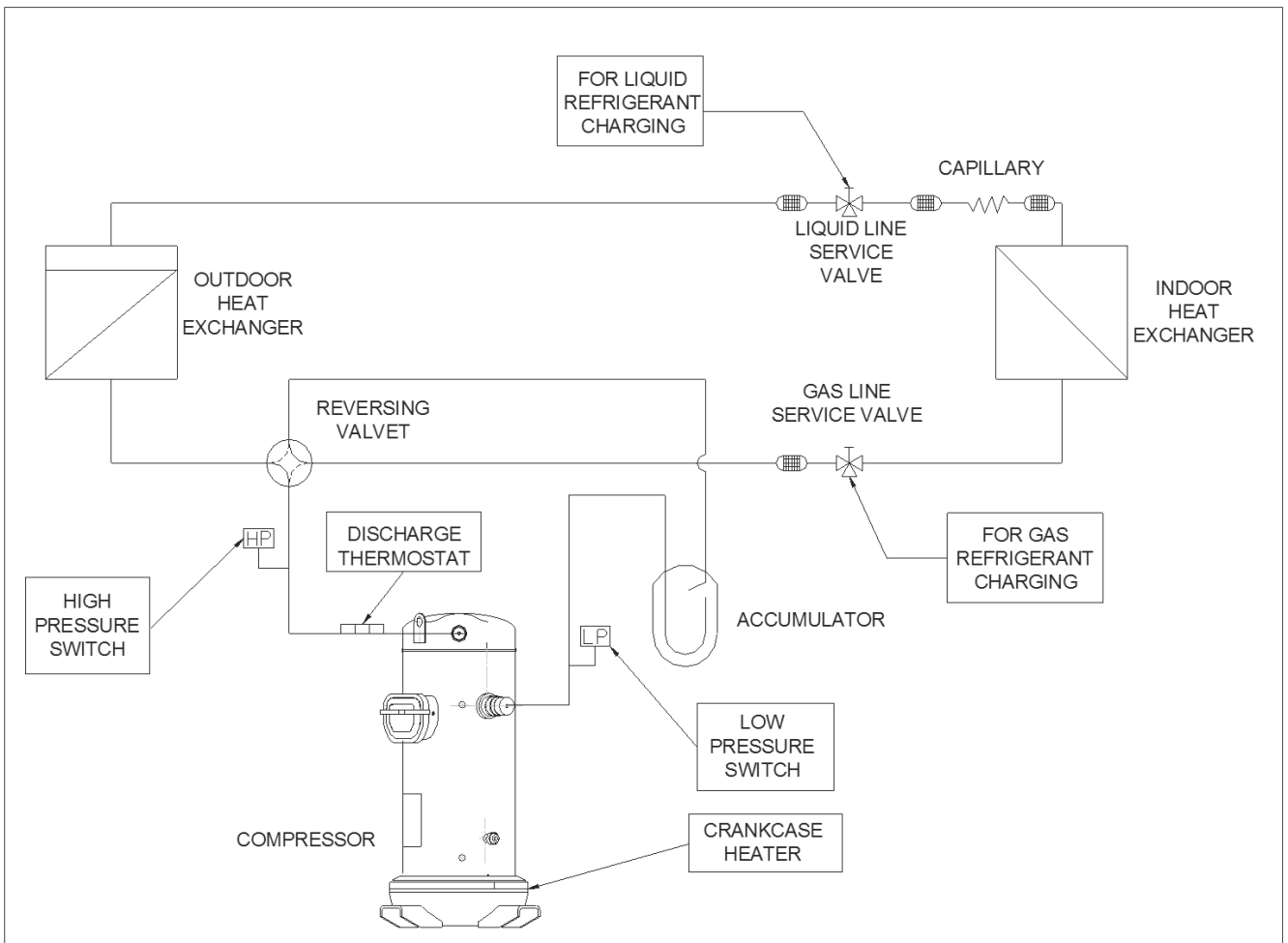

Section 5. Data Sheet

PERFORMANCE DATA

Compressor Model	5CB110SA04
Power Source	3PH 50Hz 380~415V
Suction Gas Superheat(°C)	11.1
Sub Cooling(°C)	8.3
Compressor Cooling	Natural Cooling
Refrigerant	R410A

CAPACITY(W)

Condensing Temperature(°C)	Evaporating Temperature(°C)							
	-15	-10	-6.7	0	4.4	7.2	10	12
35.0	15,890	19,350	22,030	28,680	34,100	38,070	42,500	45,980
40.5	14,640	17,790	20,220	26,240	31,140	34,720	38,710	41,840
45.0	13,680	16,590	18,840	24,380	28,880	32,170	35,840	38,700
50.0	12,680	15,340	17,400	22,460	26,550	29,540	32,870	35,470
54.4		14,320	16,220	20,880	24,650	27,400	30,450	32,840
60.0			14,840	19,050	22,440	24,910	27,640	29,780
65.0				17,560	20,650	22,900	25,380	27,320

POWER(W)

Condensing Temperature(°C)	Evaporating Temperature(°C)							
	-15	-10	-6.7	0	4.4	7.2	10	12
35.0	5,910	5,880	5,860	5,840	5,840	5,840	5,840	5,840
40.5	6,570	6,570	6,570	6,570	6,570	6,570	6,570	6,570
45.0	7,200	7,220	7,230	7,250	7,260	7,260	7,260	7,250
50.0	7,970	8,030	8,060	8,110	8,120	8,130	8,130	8,120
54.4		8,820	8,870	8,950	8,970	8,980	8,980	8,970
60.0			10,010	10,130	10,170	10,180	10,180	10,170
65.0				11,300	11,360	11,370	11,360	11,350

CURRENT(A) @380V

Condensing Temperature(°C)	Evaporating Temperature(°C)							
	-15	-10	-6.7	0	4.4	7.2	10	12
35.0	11.3	11.2	11.2	11.2	11.2	11.2	11.2	11.2
40.5	12.3	12.3	12.3	12.3	12.3	12.3	12.3	12.3
45.0	13.2	13.2	13.2	13.3	13.3	13.3	13.3	13.3
50.0	14.3	14.4	14.4	14.5	14.5	14.5	14.5	14.5
54.4		15.5	15.5	15.7	15.7	15.7	15.7	15.7
60.0			17.1	17.3	17.3	17.3	17.3	17.3
65.0				18.8	18.9	18.9	18.9	18.9

FLOW (kg/h) @380V

Condensing Temperature(°C)	Evaporating Temperature(°C)							
	-15	-10	-6.7	0	4.4	7.2	10	12
35.0	307	383	438	564	656	719	785	833
40.5	307	377	429	550	641	703	768	817
45.0	308	373	422	539	628	690	755	804
50.0	309	368	414	527	614	675	741	790
54.4		364	408	517	602	663	728	778
60.0			399	504	588	648	713	762
65.0				492	575	634	699	749

Compressor Model(Code)
Power Source

5CB110SA04
3PH 50Hz 380~415V

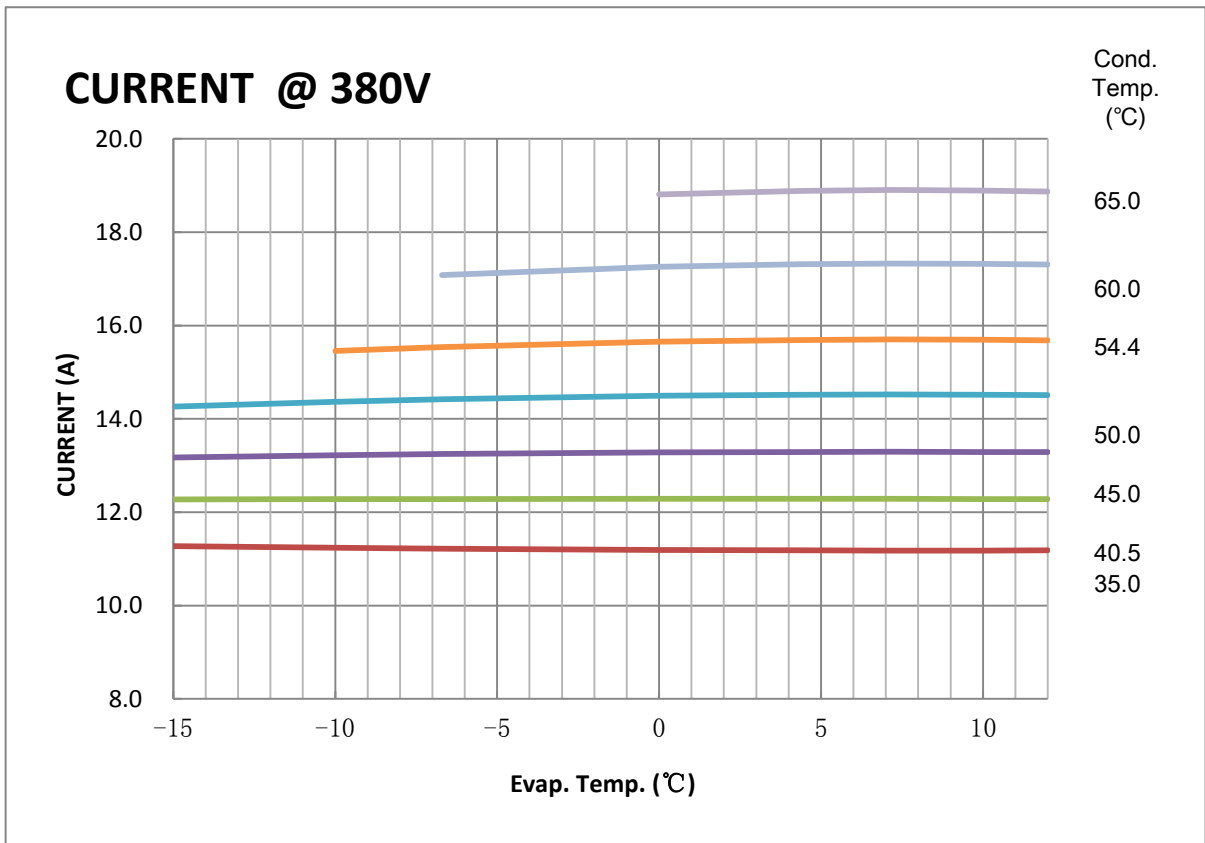
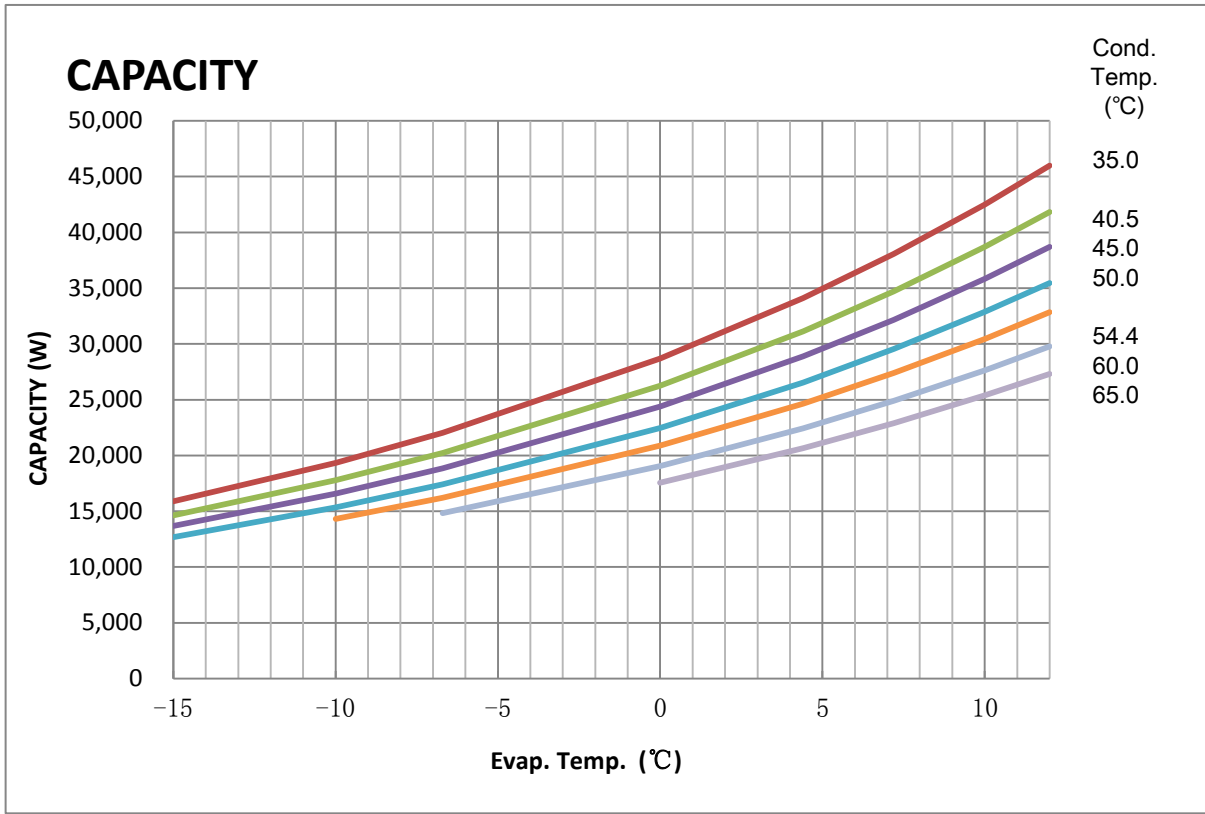

COEFFICIENTS OF PERFORMANCE CURVES

Compressor Model	5CB110SA04
Power Source	3PH 50Hz 380~415V
Suction Gas Superheat (K)	11.1
Sub Cooling (K)	8.3
Compressor Cooling	Natural Cooling
Refrigerant	R410A

$$X=C1+C2*(S)+C3*D+C4*(S^2)+C5*(S*D)+C6*(D^2)+C7*(S^3)+C8*(D*S^2)+C9*(S*D^2) +C10*(D^3)$$

X—CAPACITY(W) OR POWER(W) OR CURRENT(A) OR FLOW(kg/h)

S—EVAPORATING TEMP, °C

D—CONDENSING TEMP, °C

<u>380V-50Hz</u>	CAPACITY (W)	POWER (W)	CURRENT (A)	FLOW (kg/h)
C1	4.856535E+04	4.087251E+03	7.319727E+00	6.578572E+02
C2	2.093723E+03	1.468459E+00	-5.811663E-03	2.374735E+01
C3	-6.752168E+02	-2.077014E+01	3.333629E-02	-2.836566E+00
C4	3.561652E+01	1.445344E+00	2.079504E-03	2.216776E-02
C5	-3.330930E+01	-4.441964E-01	-3.181073E-04	-1.087691E-01
C6	3.055709E+00	2.025073E+00	2.204532E-03	4.405117E-03
C7	2.331324E-01	-4.515316E-03	-2.730198E-06	-4.605970E-05
C8	-3.780949E-01	-3.586419E-02	-5.288275E-05	4.983976E-03
C9	1.696246E-01	1.041716E-02	1.184597E-05	1.347584E-04
C10	-6.506408E-08	1.417974E-08	9.325206E-12	1.332501E-10

Note: The polynomial coefficients subject to change without notice.

Envelope

Refrigerant: R410A

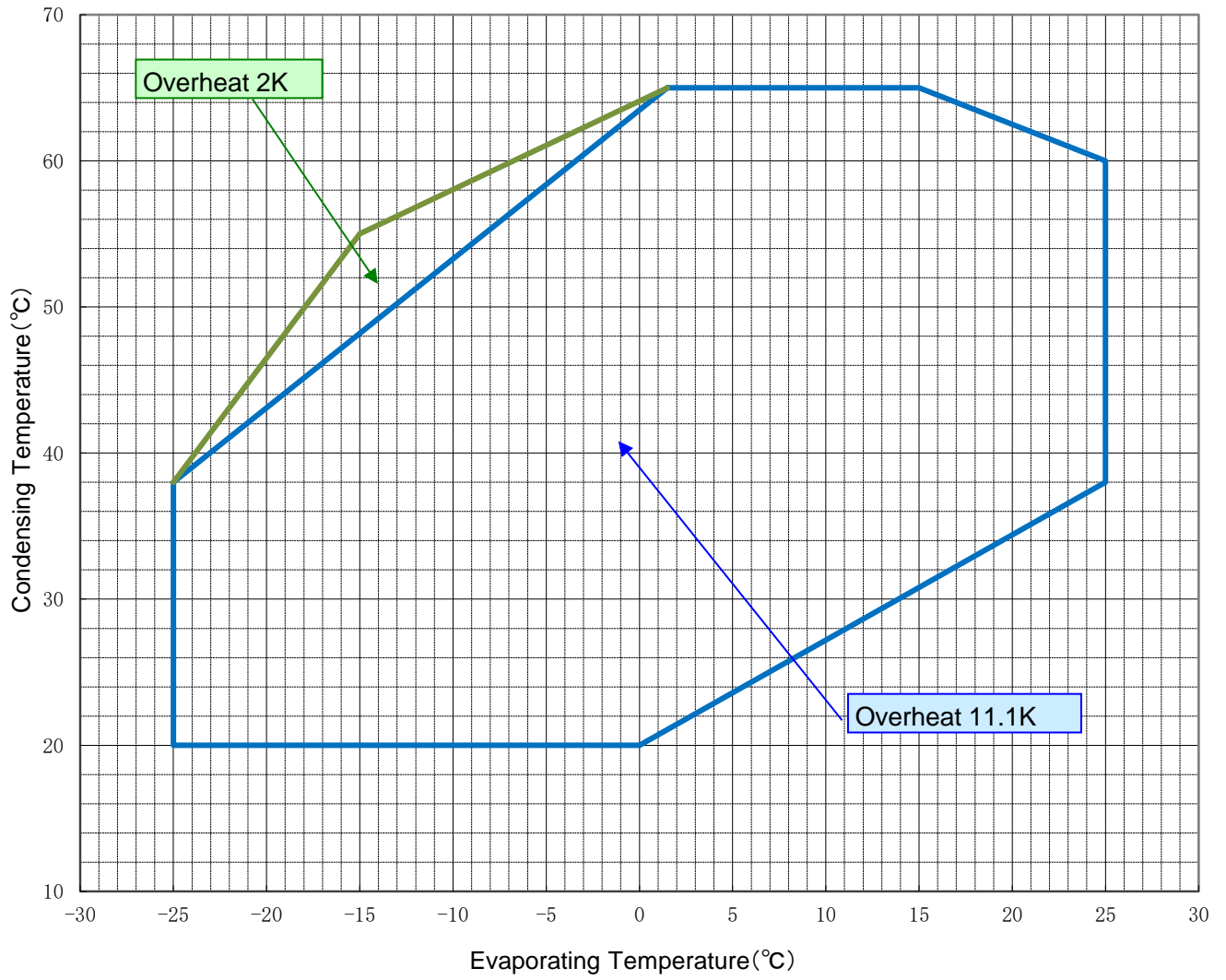

Section 6. Application Standard & Limit

The following requirements apply to vertical type hermetic scroll compressors:

Standard: Applicable to ordinary conditions in Japan JIS B8616 or equivalent conditions, such as standard rating conditions, maximum operating conditions, low temperature conditions, etc.

Limit: Applicable to transitional brief period of time, such as start-up and beginning of defrost mode.

No.	Item	Standard	Limit	Note
1	Refrigerant	R410A		
2	Evaporating Temp.	-15~+12°C (+5~+54 °F) 0.38~1.05MPa(G) (55~152psig)	-25~+15°C (-13~+59 °F) 0.23~1.15MPa(G) (33~167psig)	Compressor Suction Pressure
3	Condensing Temp.	+30~+60°C (+86~+140 ° F) 1.78~3.75MPa(G) (258~544psig)	+65°C (+149 ° F) 4.18MPa(G) (606psig)	Compressor Discharge Pressure
4	Compression Ratio	2 ~ 6	8	
5	Winding Temp.	115°C (239 °F) Max.	125°C (257 °F) Max.	
6	Shell Bottom Temp.	Upper Limit:90°C (194 °F) Max.		When compressor is running
		Lower Limit:Evaporating Temp.+12K (Min).		
		Lower Limit:Ambient Temp.+11K (Min).		When compressor shuts off
7	Discharge Gas Temp.	115°C (240 °F) Max.	C-SB:130°C (266°F) Max.	Temp. within 100mm(4in) of the discharge fitting.
				Temp. inside of the well pipe on the top of compressor
8	Suction Gas Temp.	Superheat: 5K Min.	No excessive noise	It should meet the requirement of item 5, 6, 7 and 13 within 30cm of the suction fitting.
9	Running Voltage	Within ±10% of the rated voltage		Voltage at compressor terminals.
10	Starting Voltage	Three Phase Models: 85% of the rated voltage min.		Dropped voltage at compressor terminals.
11	On/Off Cycling	On Period: Until the oil level returns to the center of the lower bearing Off Period: Until balance of high and low pressure is obtained		For at least 7 minutes -on/3 minutes-off is recommendable. 200,000 cycle Max.
12	Refrigerant Charge	oil/refrigerant(wt.)>0.35		Specific gravity of the Oil:0.94
13	Minimum Oil Level	No less than 72% of the initial oil charge		
14	Abnormal Pressure Rise/Drop	Pressure Rise: 4.15MPa(G) (602psig) Max.		By high pressure switch
		Pressure Drop: 0.15MPa(G) (22psig) Min.		By low pressure switch
15	System Moisture Level	200ppm Max.		
16	System Uncondensable Gas Level	1 Vol.% Max. Residual Oxygen 0.1 Vol.% Max.		24 hrs. after vacuuming: 1.01kPa Max.
17	Tilt	5° Deg.Max.		

Operation beyond the above limits must be approved by Panasonic Appliances Compressor (Dalian) Co., Ltd.

(G): Gauge Pressure

Notes

- 1 Installation should be completed within 15 minutes after removing the rubber plugs.
- 2 Do not use the compressor to compress air.
- 3 Do not energize the compressor under vacuumed condition.
- 4 Evacuation and Refrigerant charge : Evacuate internal section in the refrigeration system from high and low pressure sides and charge liquid refrigerant from condenser outlet side. Additional charge shall be done with gas condition from
- 5 Do not tilt over the compressor while carrying it.
- 6 Do not remove the paint.
- 7 Crankcase heater is required when the oil sump temperature is too low to meet the requirement of item 6 on page7.
- 8 Voltage fluctuation between compressor terminals, during operation, shall be within 2% of the rated voltage.
- 9 Do not operate compressor in reverse rotational direction.
- 10 Suction strainers are recommended for all applications.
- 11 Copper Piping Stress

Start/Shutdown	34.32 N/mm ² Max.
Run	12.26 N/mm ² Max.
- 12 When The Compressor body and its packaging is abandoned, Please follow every sales environmental standards, For packaging refrigerant oil ,solid recycle and dispose.
- 13 Panasonic Appliances Compressor (Dalian) Co,Ltd provide the 《Compressor Specification Common Appendix》 and 《Safty Request on the use of Compressor》 also fit this specification.
- 14 Minimum Oil Level

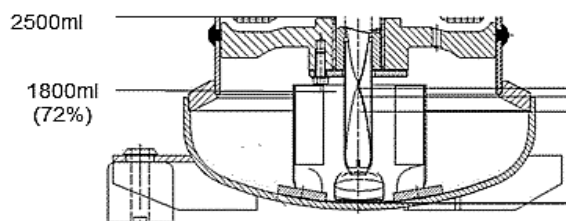

Section 7. Selection of Electrical Wire

Voltage drop may occur due to the large current draw during compressor starting.
We recommend selecting the wire size from the table below.

7.1 Type of Unit

7.1.1 Window & Commercial Type Unit

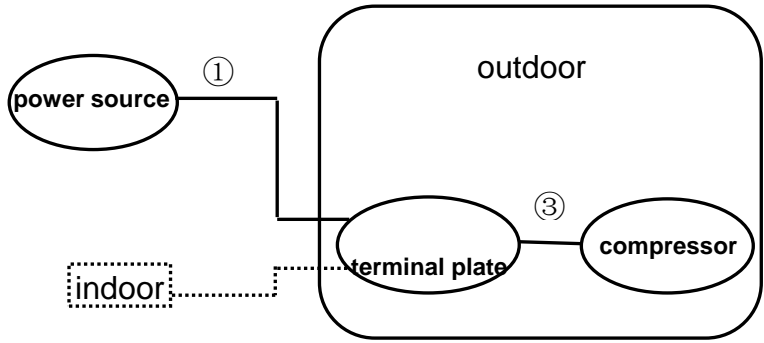

7.1.2 Split Type(Separate Type)

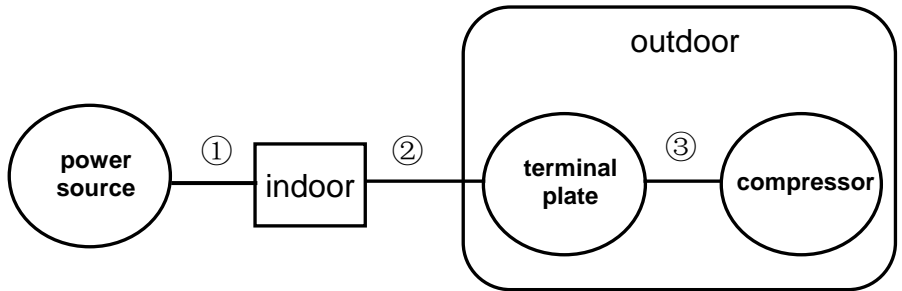

7.2 Size Table of Electrical Wire

Starting current (A)	Size of electrical wire (mm ²)						
	Remark ① Length or Remark ①+② Length (heat-resistance Temperature: 60°C(140°F) min.)						Remark ③ Length (heat-resistance Temperature: 120°C(248°F) min.)
	5m max.	10m max.	15m max.	20m max.	30m max.	50m max.	1m max.
20max.	2.0	2.0	2.0	3.5	5.5	8.0	2.0
30max.	↑	↑	3.5	5.5	↑	14.0	↑
40max.	↑	3.5	5.5	↑	8.0	↑	↑
50max.	↑	↑	↑	8.0	14.0	22.0	↑
60max.	↑	5.5	↑	↑	↑	↑	↑
70max.	3.5	↑	8.0	14.0	↑	↑	3.5
80max.	↑	↑	↑	↑	22.0	30.0	↑
90max.	↑	↑	14.0	↑	↑	↑	↑
100max.	↑	8.0	↑	↑	↑	38.0	↑
110max.	↑	↑	↑	↑	↑	↑	↑
120max.	5.5	↑	↑	22.0	30.0	↑	↑
140max.	↑	14.0	↑	↑	↑	50.0	5.5
160max.	↑	↑	22.0	↑	↑	↑	↑
180max.	↑	↑	↑	↑	38.0	60.0	8.0
200max.	8.0	↑	↑	30.0	↑	↑	↑
220max.	↑	↑	↑	↑	50.0	80.0	↑
240max.	↑	↑	↑	↑	↑	↑	8.0*

* 8.0 mm² wire can be used below 0.8m

7.4 Caution of Ground

The internal motor protector does not protect the compressor against all possible conditions.
Please be sure that the system utilizes the ground connection when installed in the field.
Earth leakage circuit breaker must be installed

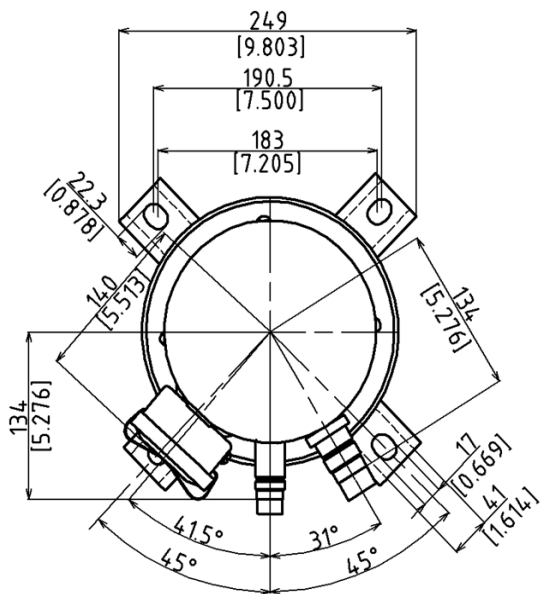
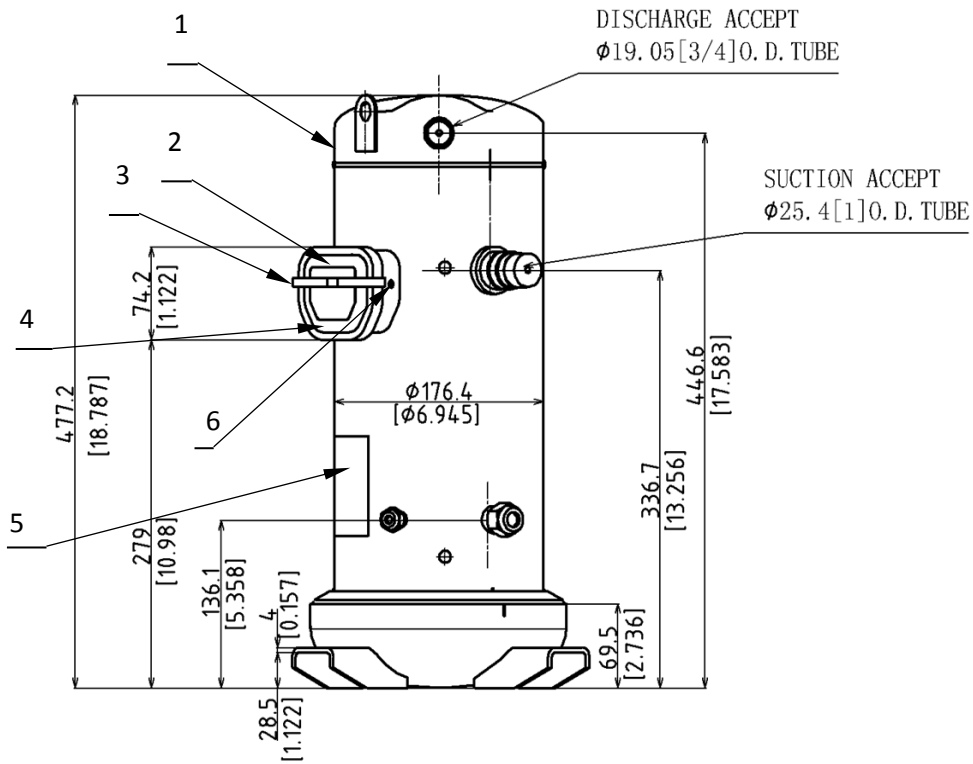

No.	Part Code	Qty	Name
1	5CB110SA04	1	Compressor
2	A-0101-DSB	1	Terminal Box Cover
3	A-0201-DSB	1	Terminal Box Clip
4	A-0301-DSB	1	Eyelet Rub Lead Wire
5		1	Nameplate
6	B-0101-DSB	1	Screw Special

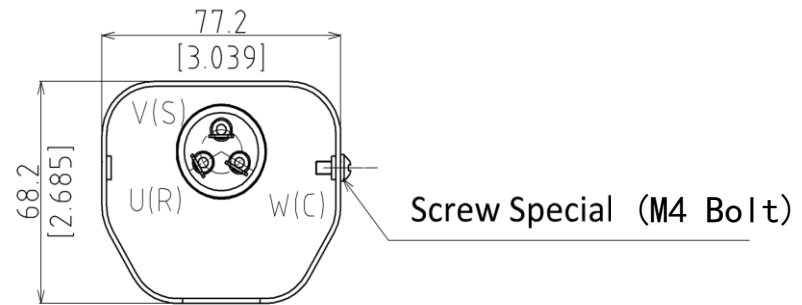

TERMINAL

Part Code

D-0105-DSB

Name

Compressor Outline Drawing

No.	Part	QTY	Name
1	M-0101-DSC	4	Mounting Grommet
2	M-0202-DSC	4	Mounting Sleeve

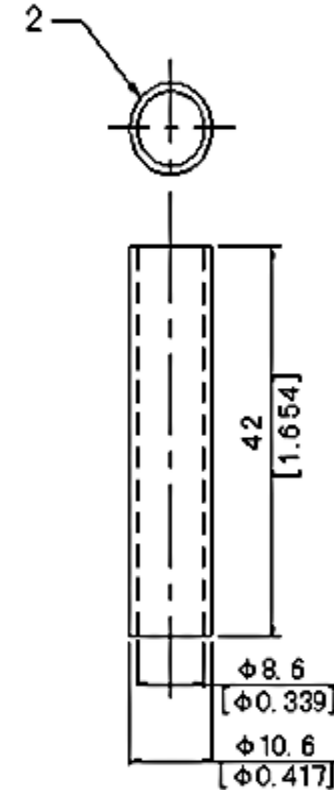
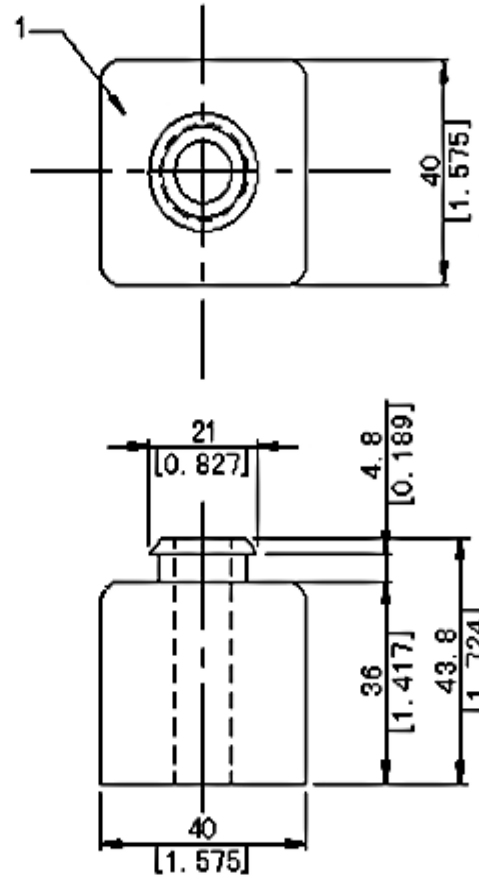
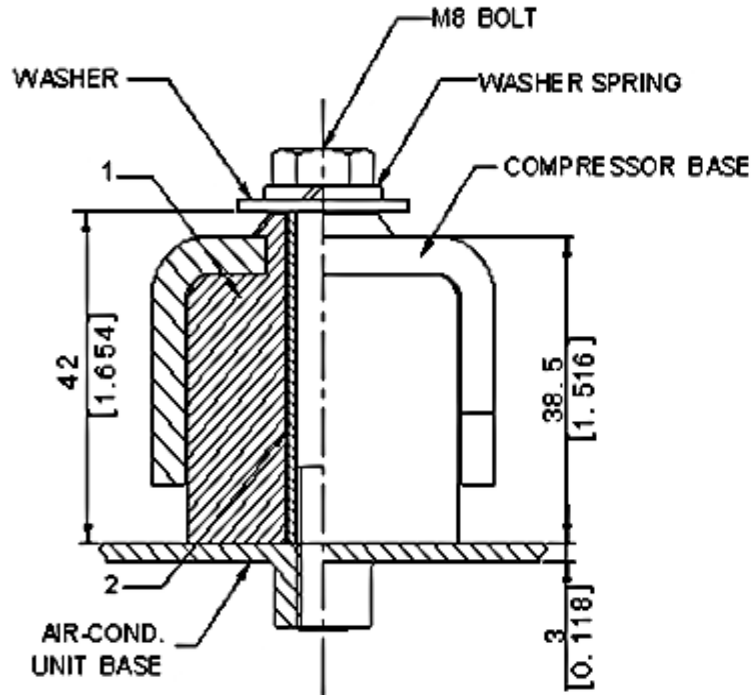

Part Code
M-5102-DSC
Name
Mounting Parts Listing

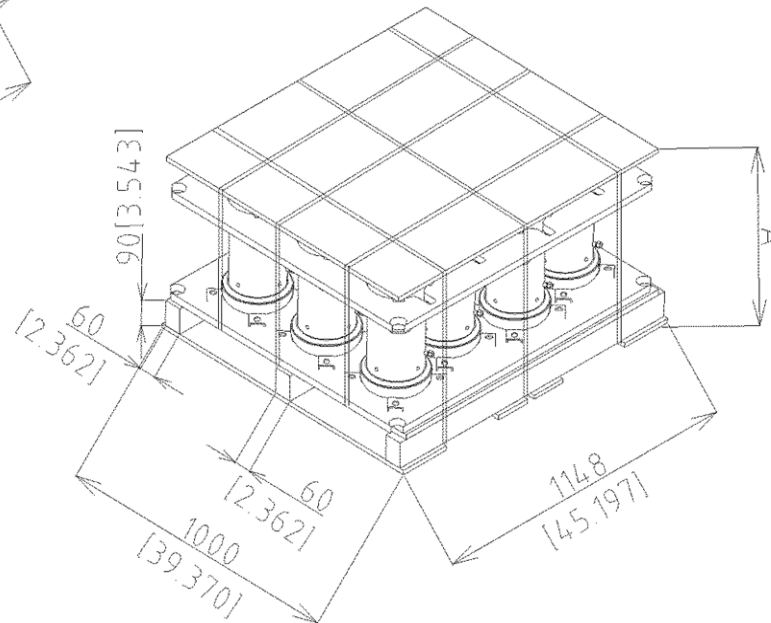
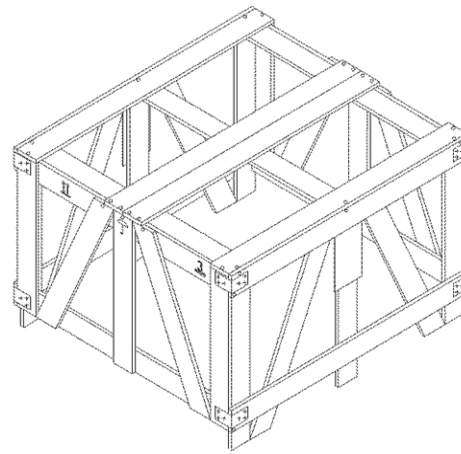
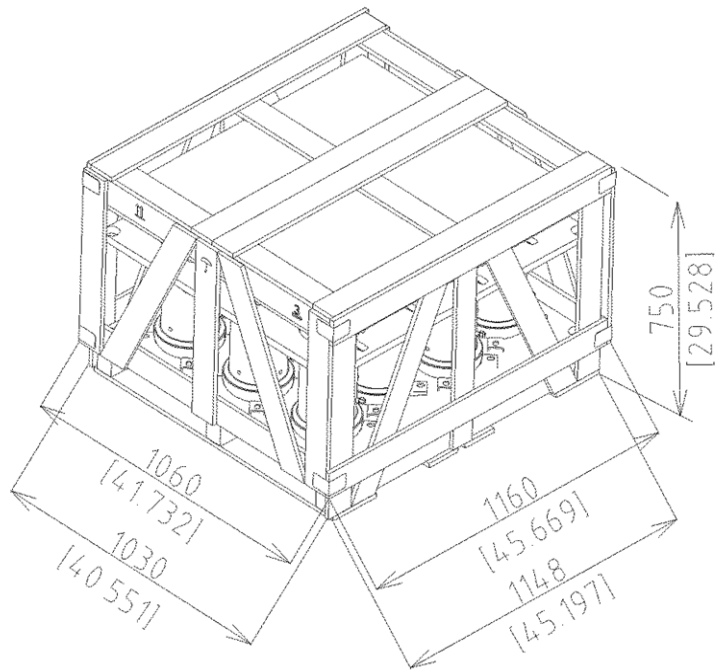

COMPRESSOR MODEL	A
5CB110SA04	613

Part Code
D-0203-DSB
Name
Packing Dimensions

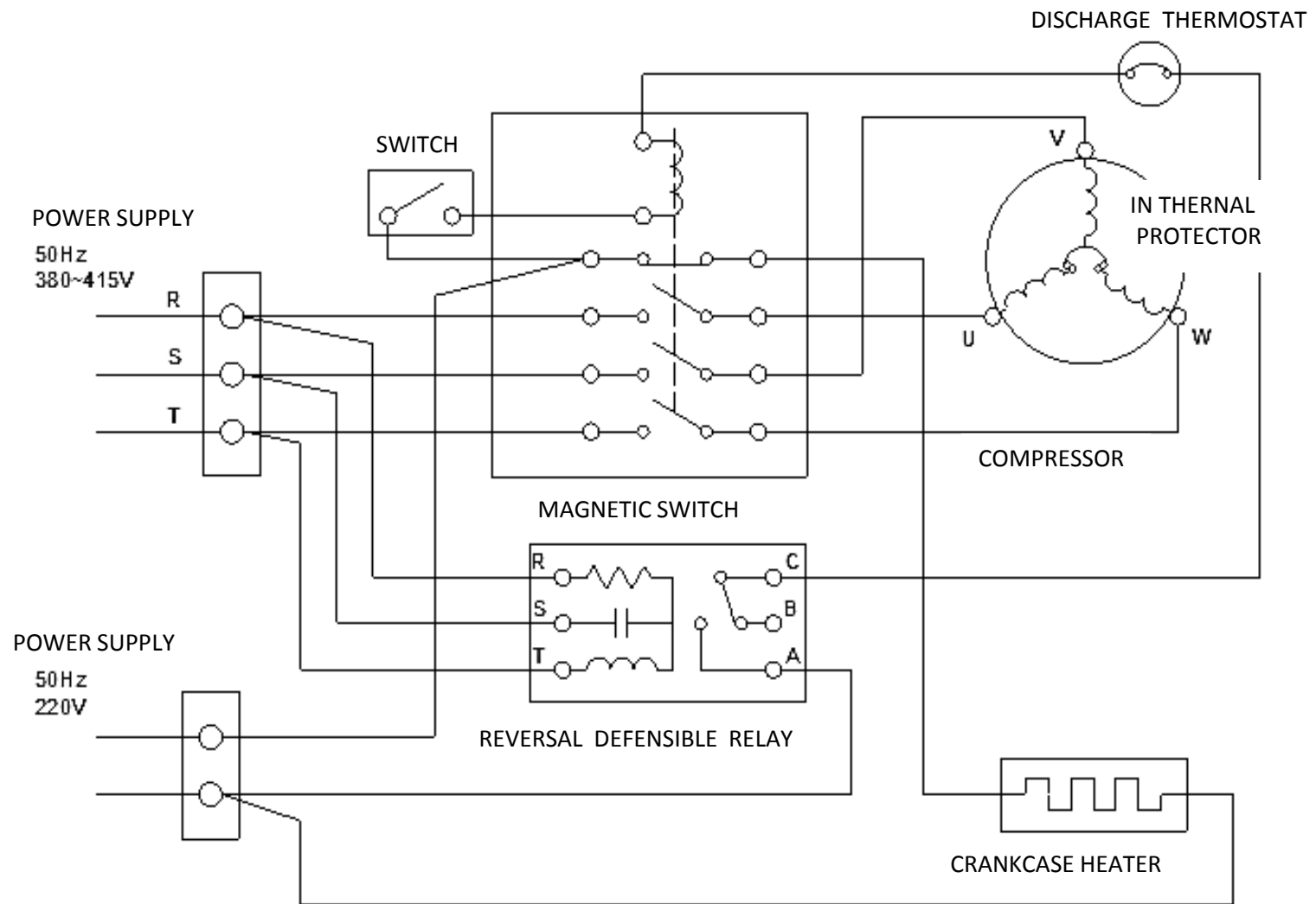
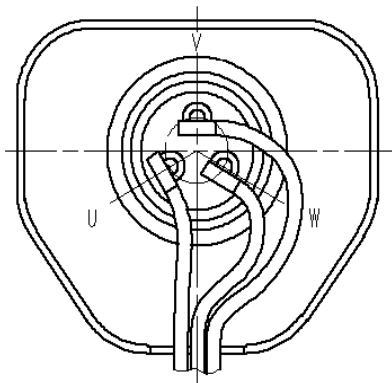

Part Code
E-0910-DSB
Name
Wiring Diagram