

Panasonic

No. : 9CB051SA04-00-GGS-0

APPROVAL SHEET SPECIFICATIONS OF HERMETIC SCROLL COMPRESSOR

MODEL	9CB051SA04
-------	------------

△					
△					
△					
△					
△					
NO.	DATE	PAGE	REVISION DETAILS	PAPCDL SIGNED	CLIENT SIGNED

REVISION RECORD

Panasonic Appliances Compressor (Dalian) Co., Ltd.

Section 1. General Specifications

Content		Unit	Specification	
Compressor Model		—	9CB051SA04	
Type		—	Hermetic Scroll Compressor	
Application		—	High Back Pressure	
Evap. Temp. Range		°C (°F)	-25~27	
Compressor Cooling Type		—	Natural Cooling	
Power Source	Phase	—	3	
	Rated Voltage	V	380~415	
	Rated Frequency	Hz	50	
Voltage Range		V	342~456	
Weight (Including Oil)		kg	37.4	
Refrigerant		—	R32	
Oil Type		—	FW68S	
Oil Charge		ml	1700	
Displacement		cm ³ /rev	51.6	
Maximum Continuous Current (MCC)		A	13.1	
Motor	Motor Type	—	3-PH Induction Motor	
	Number of Poles	—	2	
	Electrical Insulation	—	E	
	Nominal Revolution	min ⁻¹	—	
	Starting Current	A	66	
	Winding Resistance [at 25°C (77°F)]	Ω	U-V	2.433
			U-W	2.433
V-W			2.304	
Connection Tube	Suction Line (O.D.)	mm (in)	22.2 (0.875)	
	Discharge Line (O.D.)	mm (in)	12.7 (0.500)	
Compressor Surface Paint		—	Black Paint	
Nitrogen sealing capacity		Mpa	0.1~0.15	

Notes

- 1 Voltage range is applied at standard rating conditions.
- 2 Motor specifications in the table are the average values for your reference.

Expiration of Specification

Expiration of this specification shall be effected until issuing a notice with indication of the expiration date from the issued date . In case of improvement or elimination of this specification , it shall be handled by the revision record based on agreement between both sides.

Section 2. Performance Warranty

2.1 Performance (PRELIMINARY DATA)

Power Source (3PH)	Hz	50	Remark
	V	380	
Refrigerant	—	R32	
Capacity	W	13,700	
	(BTU/hr)	46,744	
Input Power	W	4,800	
Current	A	8.30	

Standard Rating Conditions

Refrigerant.	—	R32
Condensing Temp.	°C	54.4
Evaporating Temp.	°C	7.2
Suction Gas Temp.	°C	18.3
Liquid Temp.	°C	46.1
Ambient Temp.	°C	35.0

Note: Sampling inspection in the factory according to the new GB/T18429-2018 working conditions

C.T:54.5°C E.T:7.0°C S.T:18.5°C L.T:46.0°C

2.2 Sound Level

Power Source (3PH)	Hz	50
	V	380
Sound Level	dB(A)	60Max.
Notes		
1 The operating conditions are the same as 2.1.		
2 MIC location is the distance of 1m (3.28feet) from the compressor.		
3 Sound Level is an average sound pressure level in four directions.		

2.3 Minimum Starting Voltage

Power Source (3PH)	Hz	50
Minimum Starting Voltage	V	323

Conditions

Compressor Temp.	°C	10~60
Ambient Temp.	°C	10~40
High Pressure	MPa(G)	3.38
Low Pressure	MPa(G)	0.91

2.4 Others

Content		Unit	Specification
Design Pressure	L.P. S.	MPa(G)	2.8
	H. P. S.	MPa(G)	4.5
Insulation Resistance		MΩ	100 (without refrigerant)
Dielectric Strength (The leakage current is less than 10mA)		V	1900 (1 minute)
Residual Moisture		mg	300

Note:

1. The insulation resistance be measured with a DC500V megohm tester.

Model: 9CB051SA04

File No: 9CB051SA04-00-GGS-0

Section 3. Standard Accessories

3.1 Accessories List

Parts Name	Qty	Parts code	Revision No.	Note
Terminal Box Cover	1	A-0101-DSB	0	Installed on Compressor
Terminal Box Clip	1	A-0201-DSB	0	Installed on Compressor
Eyelet Rub Lead Wire	1	A-0301-DSB	0	Installed on Compressor
Mounting Grommet	4	M-0101-DSB	0	
Mounting Sleeve	4	M-0201-DSB	0	
Screw Special	2	B-0101-DSB	0	Installed on Compressor

3.2 The Drawing for Reference

Parts Name	Parts Code	Revision No.
Compressor Outline Drawing	D-0101-DSB	0
Mounting Parts Listing	M-5101-DSB	0
Packing Dimensions	D-0202-DSB	0
Wiring Diagram	E-0910-DSB	0

3.3 Internal Motor Protector (in compressor)

Parts Name	Specification		
Internal Motor Protector	Model	UP18MA052-770 *3	37HM530-15 *3
	Trip Temperature	130±5℃	125±5℃
	Reset Temperature	70±10℃	65±9℃
	Trip Current	46A / 3~10s	50A / 3~10s

1. When the protector is not on current, the ambient temperature of the protector rises to the temperature of protector which is for touching current and off, this is operating temperature. Then, the ambient temperature of the protector goes down the moment it touches current and closes, at this moment, the temperature of the protector is recovery temperature.
2. When the current of compressor is overloaded, under the ambient temperature 25℃, the protector can guarantee the motion in the limited current within the first operating circles 3-10seconds.
3. Please kindly choose either of one.

Section 4. Compressor Protection

4.1 Protection Required but not Included with compressor

Protection Device	Items	Specifications
Reversal Defensible Relay	Features	To protect the compressor from reverse rotation
	Rated Voltage	AC380V
Crankcase Heater	Rated Power	35 W 240V
Discharge Thermostat	Mounting Position	Located within 100mm(4 in)from the compressor shell
	Trip Temperature	130±5°C
	Reset Temperature	95±11°C
High Pressure Switch	Setting	Cut-out seting no higher than 4.5Mpa(G)
Low Pressure Switch	Setting	Cut-out seting no lower than 0.23Mpa(G)

4.2 Position of the Protection and Refrigerant Charging

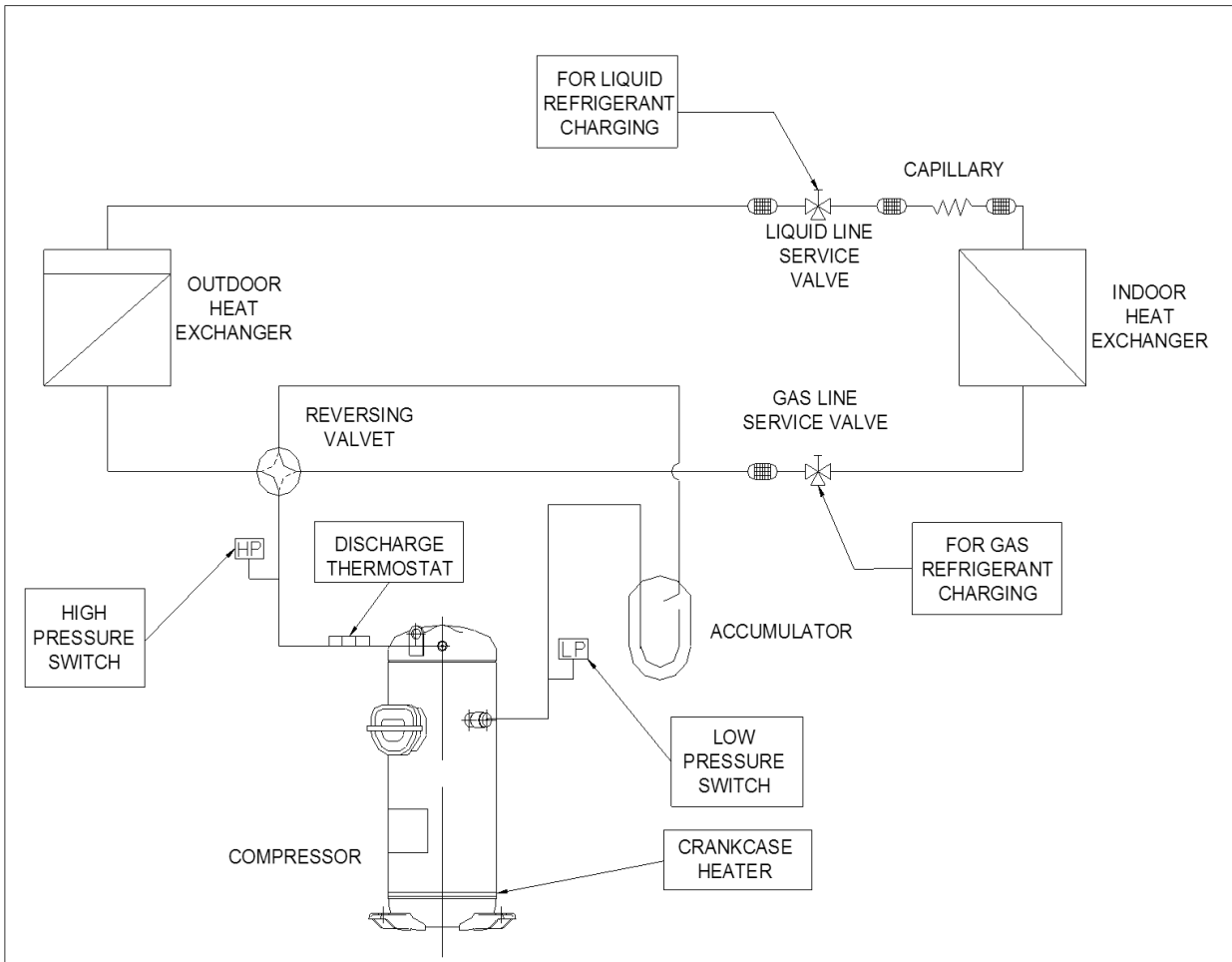

Section 5. Operating Envelope

Refrigerant : R32.

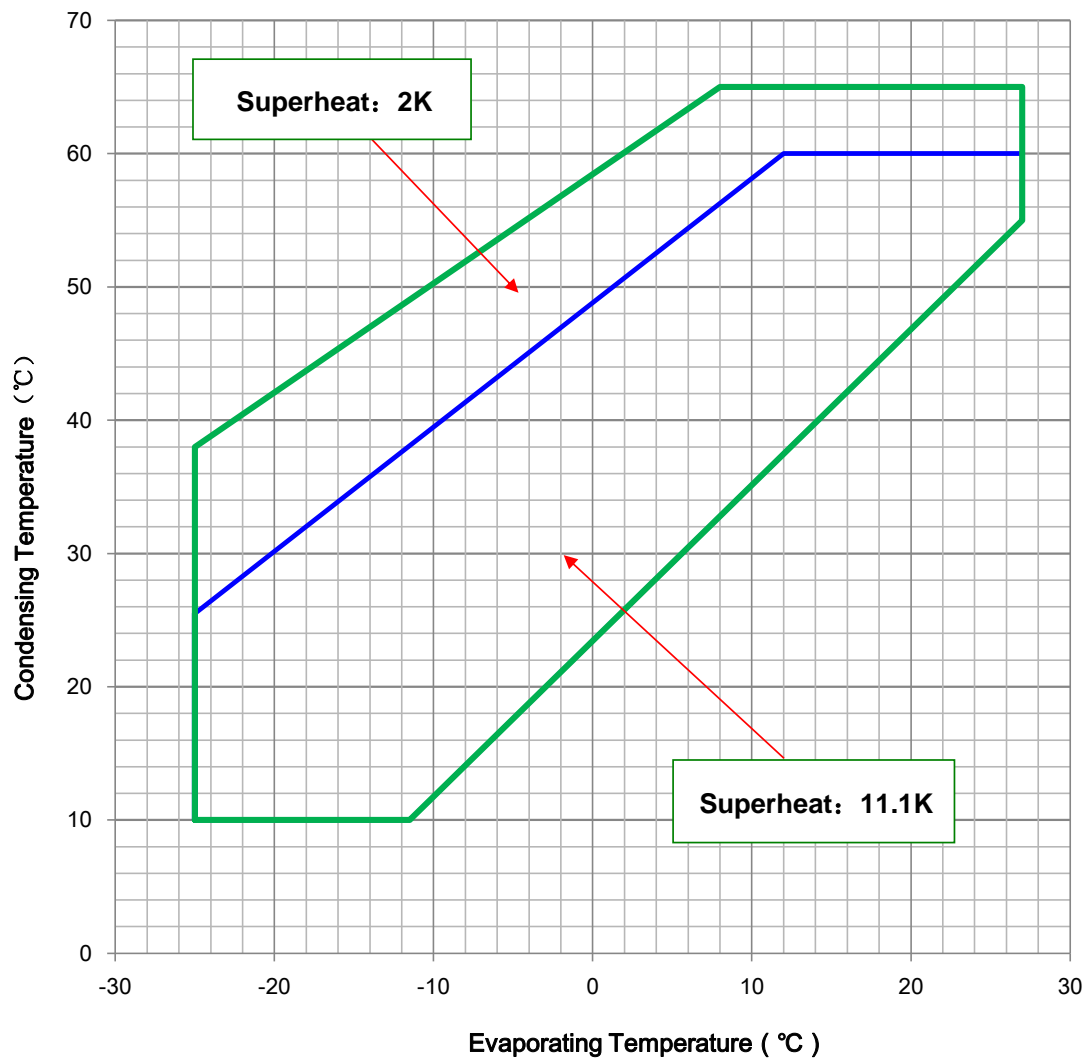

Section 6. Application Standard & Limit

The following requirements apply to vertical type hermetic scroll compressors:

Standard: Applicable to ordinary conditions in Japan JIS B8616 or equivalent conditions, such as standard rating conditions, maximum operating conditions, low temperature conditions, etc.

Limit: Applicable to transitional brief period of time, such as start-up and beginning of defrost mode.

No.	Item	Standard	Limit	Note
1	Refrigerant	R32		
2	Evaporating Temp.	-25~27℃ 0.24~1.68MPa (G)		Compressor Suction Pressure
3	Condensing Temp.	+10~+65℃ 1.00~4.27MPa (G)		Compressor Discharge Pressure
4	Compression Ratio	2~8		
5	Winding Temp.	115℃ Max.	125℃	
6	Shell Bottom Temp.	Upper Limit:90℃Max.		
		Lower Limit:Evaporating Temp.+12℃Min.		
		Lower Limit:Ambient Temp.+11℃Min.		
7	Discharge Gas Temp.	130℃ Max.		Temp. within 100mm(4in) of the discharge fitting.
8	Suction Gas Temp.	Superheat: 2K Min.	No excessive noise (no increase of current and alarm)	It should meet the requirement of item 5, 6, 7 and 14 within 30cm of the suction fitting.
9	Running Voltage	Within ±10% of the rated voltage		Voltage at compressor terminals.
10	Starting Voltage	Three Phase Models: 85% of the rated voltage min.		Dropped voltage at compressor terminals.
		Single Phase Models: 90% of the rated voltage min.		
11	On/Off Cycling	On Period: Until the oil level returns to the center of the lower bearing Off Period: Until balance of high and low pressure is obtained		
12	Refrigerant Charge	oil/refrigerant(wt.)>0.35		Specific gravity of the Oil:0.94
13	Minimum Oil Level	Center of the lower bearing	Bottom of the lower bearing	
14	Abnormal Pressure Rise/Drop	Pressure Rise: 4.5MPa(G) Max.		By high pressure switch
		Pressure Drop: 0.23MPa(G) Min.		By low pressure switch
15	System Moisture Level	200ppm Max.		
16	System Uncondensable Gas Level	1 Vol.% Max. Residual Oxygen 0.1 Vol.% Max.		24 hrs. after vacuuming: 1.01kPa Max.
17	Tilt	5° Deg.Max.		

Operation beyond the above limits must be approved by Panasonic Appliances Compressor (Dalian) Co., Ltd.

(G): Gauge Pressure

Notes

- 1 Installation should be completed within 15 minutes after removing the rubber plugs.
- 2 Do not use the compressor to compress air.
- 3 Do not energize the compressor under vacuumed condition.
- 4 Evacuation and Refrigerant charge : Evacuate internal section in the refrigeration system from high and low pressure sides and charge liquid refrigerant from condenser outlet side. Additional charge shall be done with gas condition from low side.
- 5 Do not tilt over the compressor while carrying it.
- 6 Do not remove the paint.
- 7 Crankcase heater is required when the oil sump temperature is too low to meet the requirement of item 6 on page 7.
- 8 Voltage fluctuation between compressor terminals, during operation, shall be within 2% of the rated voltage.
- 9 Do not operate compressor in reverse rotational direction.
- 10 Suction strainers are recommended for all applications.
- 11 Copper Piping Stress

Start/Shutdown	34.32 N/mm ² Max.
Run	12.26 N/mm ² Max.
- 12 When The Compressor body and its packaging is abandoned, Please follow every sales environmental standards,
For packaging refrigerant oil, solid recycle and dispose.
- 13 Panasonic Appliances Compressor (Dalian) Co., Ltd provide the 《Compressor Specification Common Appendix》 and 《Safety Request on the use of Compressor》 also fit this specification.

Section 7. Selection of Electrical Wire

Voltage drop may occur due to the large current draw during compressor starting.

We recommend selecting the wire size from the table below.

7.1 Type of Unit

7.1.1 Window & Commercial Type Unit

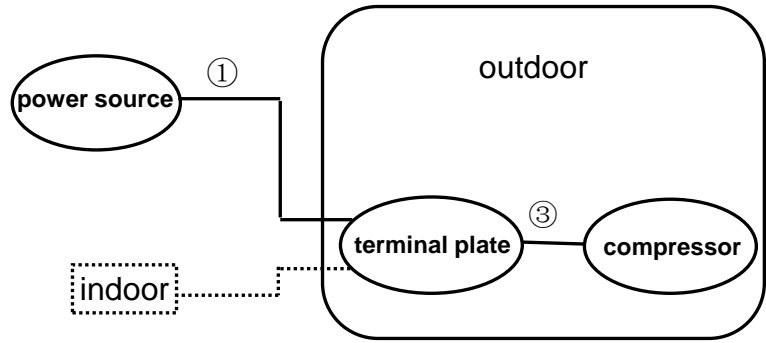

7.1.2 Split Type(Separate Type)

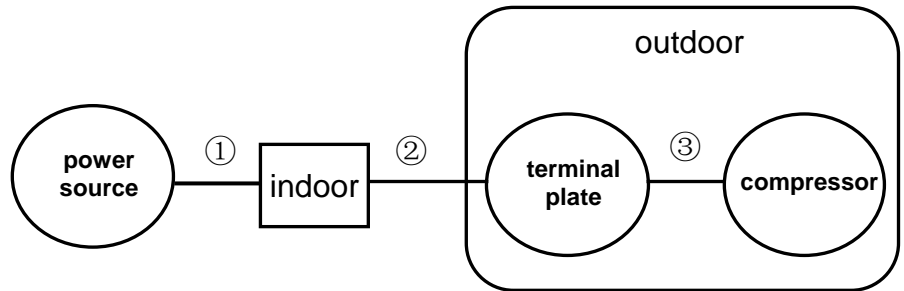

7.2 Size Table of Electrical Wire

Starting current (A)	Size of electrical wire (mm ²)						
	Remark ① or Remark ①+② (heat-resistance Temperature: 60°C min.)						Remark③ (heat-resistance Temperature: 120°Cmin.)
	5m max.	10m max.	15m max.	20m max.	30m max.	50m max.	1m max.
20max.	2.0	2.0	2.0	3.5	5.5	8.0	2.0
30max.	↑	↑	3.5	5.5	↑	14.0	↑
40max.	↑	3.5	5.5	↑	8.0	↑	↑
50max.	↑	↑	↑	8.0	14.0	22.0	↑
60max.	↑	5.5	↑	↑	↑	↑	↑
70max.	3.5	↑	8.0	14.0	↑	↑	3.5
80max.	↑	↑	↑	↑	22.0	30.0	↑
90max.	↑	↑	14.0	↑	↑	↑	↑
100max.	↑	8.0	↑	↑	↑	38.0	↑
110max.	↑	↑	↑	↑	↑	↑	↑
120max.	5.5	↑	↑	22.0	30.0	↑	↑
140max.	↑	14.0	↑	↑	↑	50.0	5.5
160max.	↑	↑	22.0	↑	↑	↑	↑
180max.	↑	↑	↑	↑	38.0	60.0	8.0
200max.	8.0	↑	↑	30.0	↑	↑	↑
220max.	↑	↑	↑	↑	50.0	80.0	↑
240max.	↑	↑	↑	↑	↑	↑	14.0

* 0.8m Max

7.3 Caution of Ground

The internal motor protector does not protect the compressor against all possible conditions.

Please be sure that the system utilizes the ground connection when installed in the field.

Earth leakage circuit breaker must be installed.

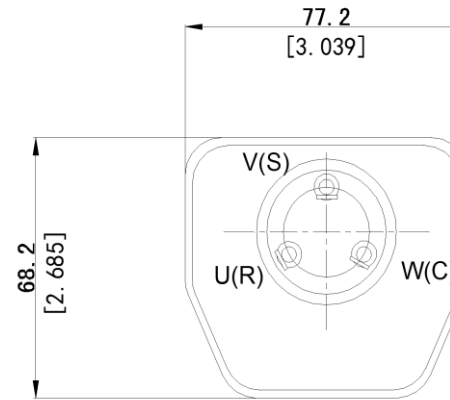
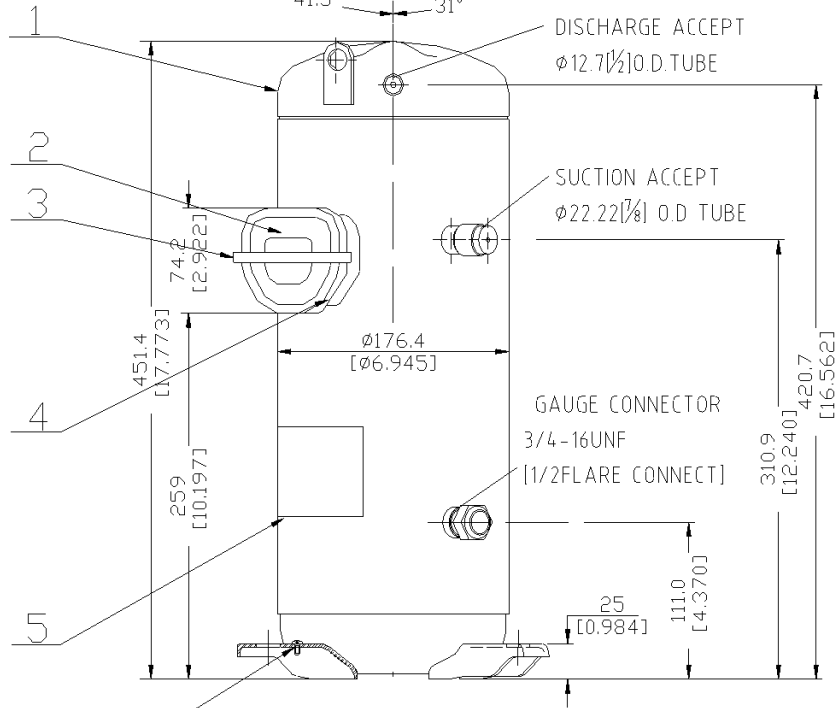
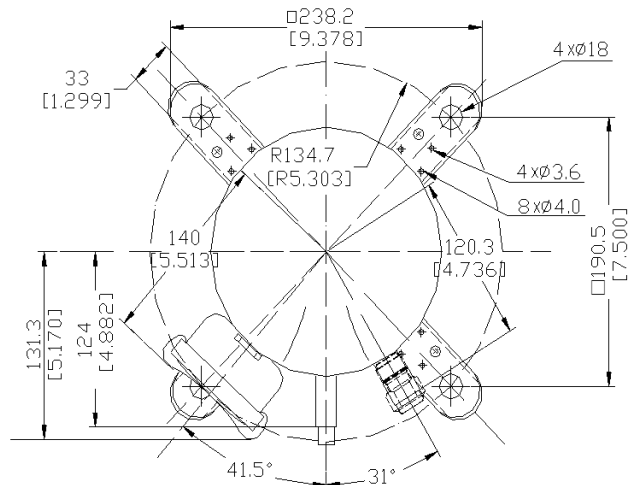

TERMINAL

No.	Part Code	Qty	Name
1	9CB051SA04	1	Compressor
2	A-0101-DSB	1	Terminal Box Cover
3	A-0201-DSB	1	Terminal Box Clip
4	A-0301-DSB	1	Insulating Grommet
5		1	Nameplate
6	B-0101-DSB	2	Screw Special

Part Code

D-0101-DSB-0

Name

Compressor Outline Drawing

No.	Part	QTY	Name
1	M-0101-DSB	4	Mounting Grommet
2	M-0201-DSB	4	Mounting Sleeve
3	B-0101-DSB	2	Screw Special

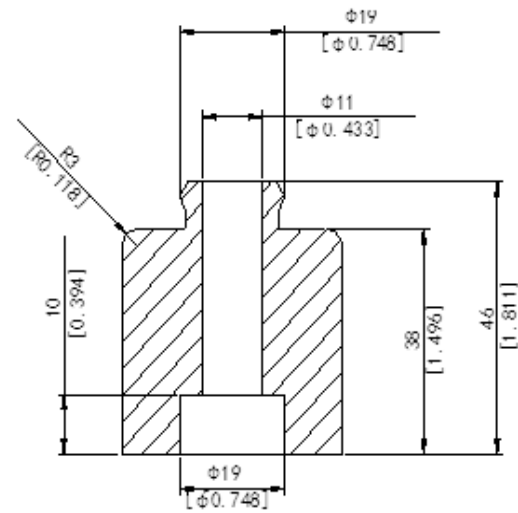
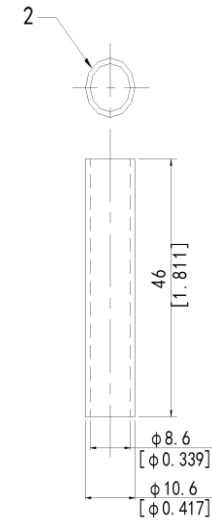
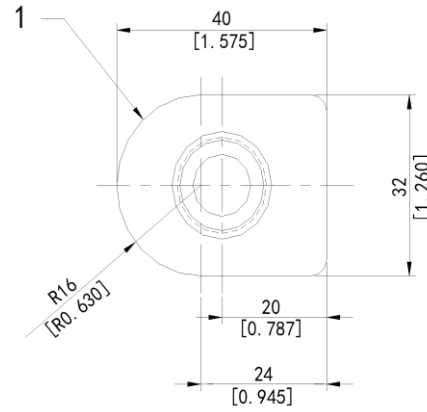
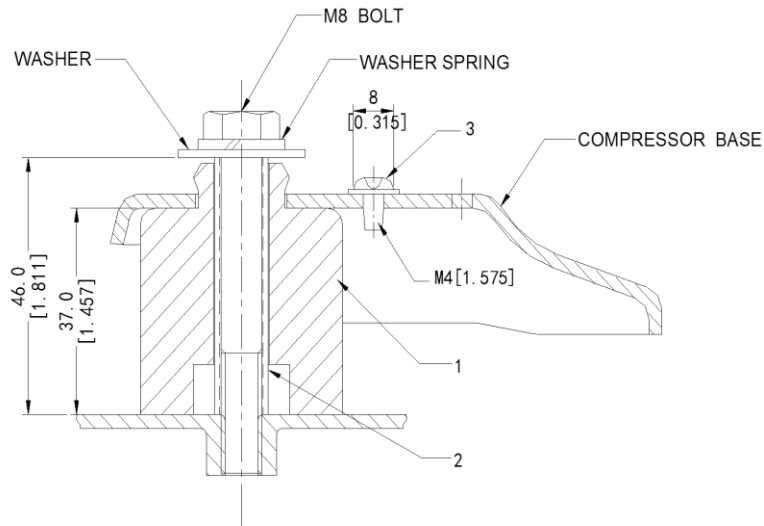

Part Code
M-5101-DSB-0
Name
Mounting Parts Listing

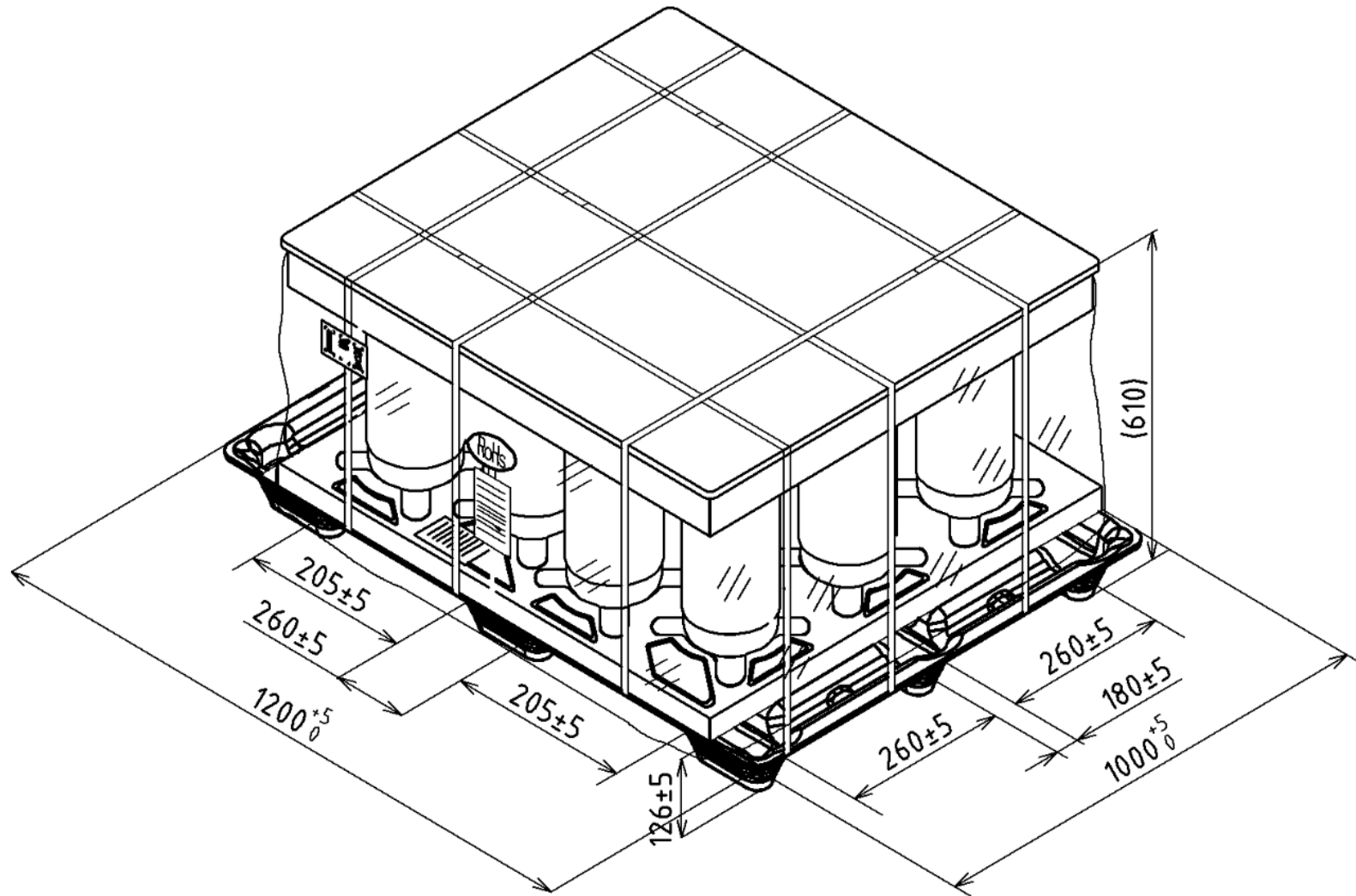

Part Code
D-0204-DSB-0
Name
Packing Dimensions

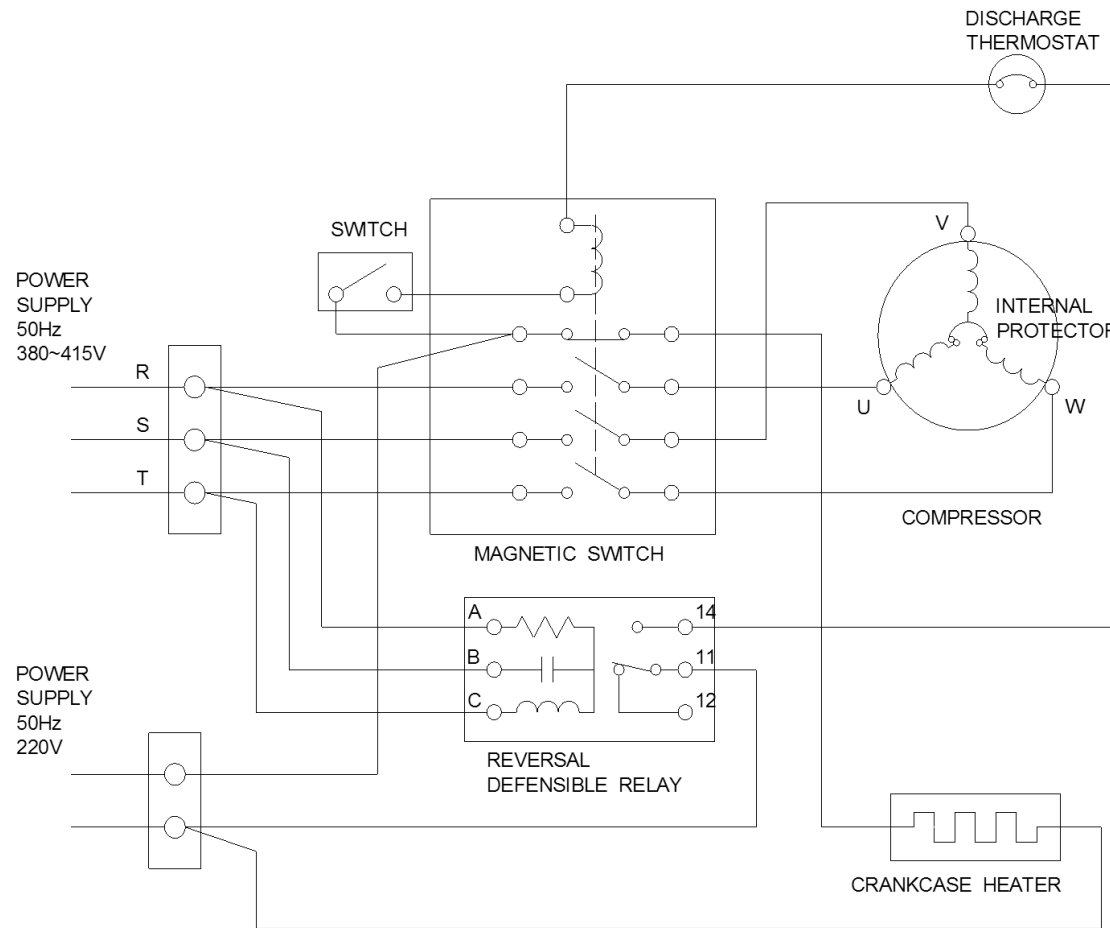
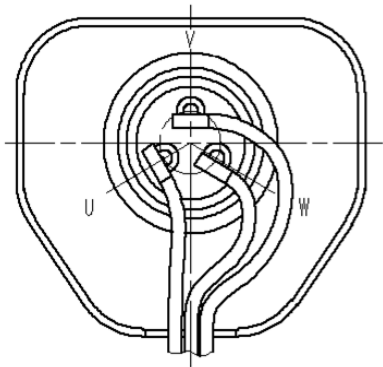

Part Code
E-0910-DSB-0
Name
Wiring Diagram