



SPECIFICATIONS OF COMPRESSOR

Model No: C-SCS295H38Q

Output : 8 HP



Temporary

DALIAN SANYO COMPRESSOR Co.,Ltd.

06-May-09

GENERAL SPECIFICATIONS

Model No:		C-SCS295H38Q
Application		
Evaporating Temp Range	(°C)	-30.0 ~ 15.0
Refrigerant		R407C
Compressor Cooling		Gas Injection
Rated Performance		
Heating Capacity	(W)	35200
Input	(W)	8700
Current	(A)	14.8
Revolution	(min ⁻¹)	2846
Sound Level	(dB(A))	
Rating Conditions		
Power Source		3-PH 50Hz 380V
Evaporating Temp	(°C)	7.2
Condensing Temp	(°C)	54.4
Suction Gas Temp	(°C)	18.3
Liquid Temp	(°C)	50.4
Ambient Temp	(°C)	35.0
Test Conditions are Mid point.		
Measuring Point of Sound Level		
Distance from the Compressor	(m)	1.0
Compressor		
Design		Hermetic Scroll
Displacement	(cm ³)	137.0
Suction Line Connection	(Φmm OD)	25.4
Discharge Line Connection	(Φmm OD)	19.05
Oil	(ml)	2800 (FV68S)
Mass(Incl.Oil)	(kg)	70
Motor		
Type		3-PH Induction Motor(3IR)
Pole		2
Rated Power Source		3-PH 50Hz 380-415V
Voltage Range	(V)	342~456
Starting Current	(A)	80

DALIAN SANYO COMPRESSOR Co.,Ltd.

PERFORMANCE CURVE

Code No.	C-SCS295H38Q
Power Source	3-PH 50Hz 380V
Condensing Temp.(°C)	30, 35, 40.5, 45, 50, 54.4, 60, 65
Suction Gas Superheat(K)	11.1
Sub Cooled(K)	4
Compressor Cooling	Gas Injection
Refrigerant	R407C
Test Conditions are Mid point.	

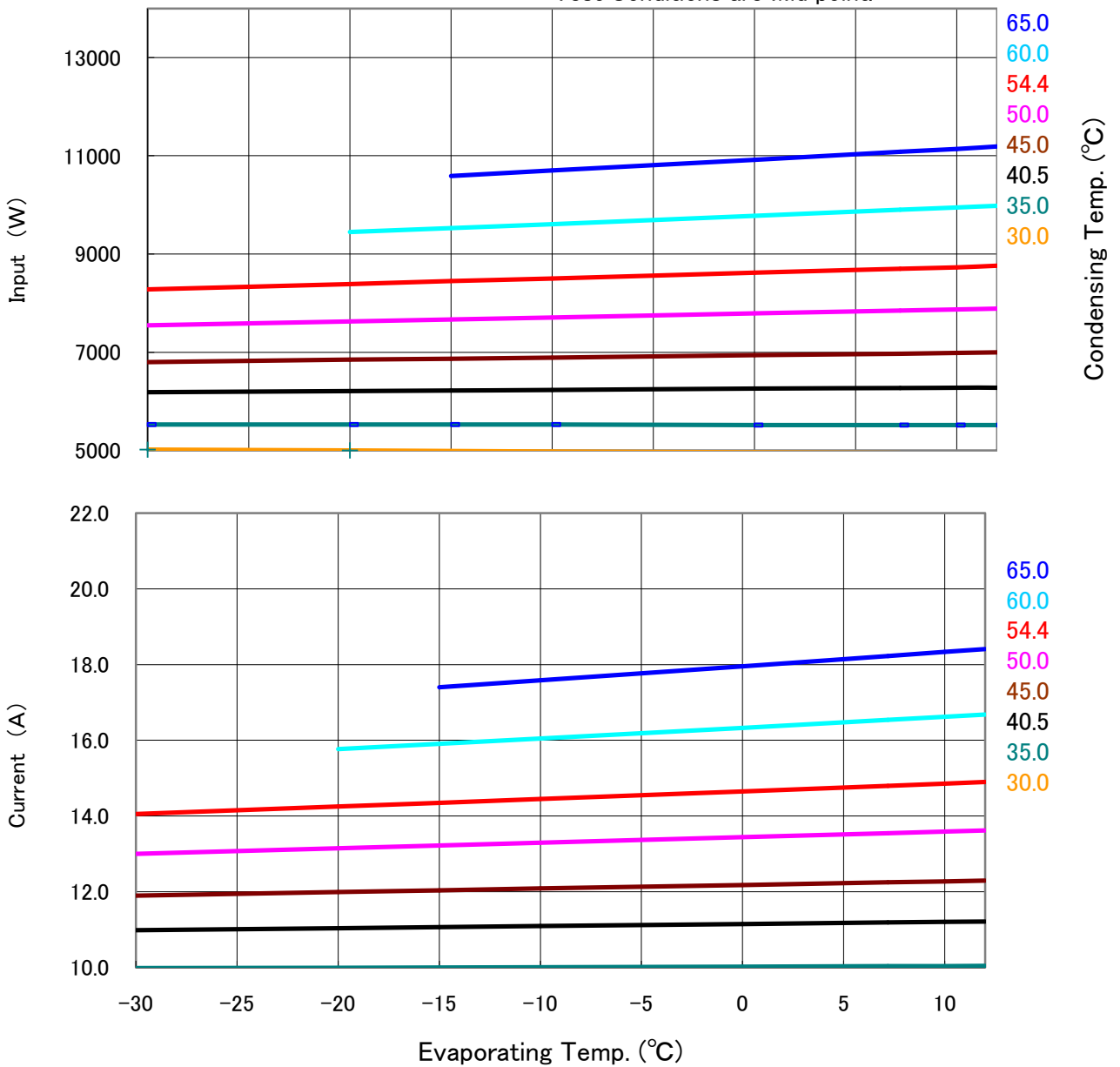

PERFORMANCE DATA

Code No.	C-SCS295H38Q
Power Source	3-PH 50Hz 380V
Condensing Temp.(°C)	30, 35, 40.5, 45, 50, 54.4, 60, 65
Suction Gas Superheat(K)	11.1
Sub Cooled(K)	4
Compressor Cooling	Gas Injection
Refrigerant	R407C

Test Conditions are Mid point.

Heating Capacity (W)

		Evaporating Temp. (°C)							
		-30	-20	-15	-10	0	7.2	10	12
Condensing Temp. (°C)	30	12,580	16,750	19,330	22,300	29,690	36,480	39,520	41,840
	35	12,990	17,110	19,640	22,540	29,690	36,210	39,110	41,330
	40.5	13,460	17,520	19,990	22,810	29,700	35,920	38,680	40,770
	45.0	13,850	17,860	20,290	23,040	29,710	35,690	38,320	40,320
	50.0	14,300	18,250	20,620	23,290	29,720	35,430	37,930	39,830
	54.4	14,710	18,600	20,910	23,510	29,730	35,200	37,590	39,400
	60.0		19,050	21,290	23,800	29,740	34,910	37,160	38,850
	65.0			21,640	24,060	29,750	34,660	36,780	38,380

Input (W)

		Evaporating Temp. (°C)							
		-30	-20	-15	-10	0	7.2	10	12
Condensing Temp. (°C)	30	5,020	5,000	4,990	4,980	4,960	4,950	4,940	4,940
	35	5,530	5,530	5,530	5,530	5,520	5,520	5,520	5,520
	40.5	6,190	6,210	6,220	6,230	6,260	6,270	6,280	6,280
	45.0	6,800	6,850	6,870	6,890	6,940	6,970	6,990	7,000
	50.0	7,550	7,630	7,670	7,710	7,790	7,850	7,870	7,890
	54.4	8,280	8,390	8,450	8,500	8,620	8,700	8,730	8,760
	60.0		9,450	9,530	9,610	9,780	9,900	9,950	9,980
	65.0			10,590	10,700	10,920	11,080	11,140	11,190

Current (A)

		Evaporating Temp. (°C)							
		-30	-20	-15	-10	0	7.2	10	12
Condensing Temp. (°C)	30	9.2	9.2	9.2	9.1	9.1	9.1	9.1	9.1
	35	10.0	10.0	10.0	10.0	10.0	10.0	10.0	10.0
	40.5	11.0	11.0	11.1	11.1	11.2	11.2	11.2	11.2
	45.0	11.9	12.0	12.0	12.1	12.2	12.2	12.3	12.3
	50.0	13.0	13.1	13.2	13.3	13.4	13.5	13.6	13.6
	54.4	14.1	14.3	14.4	14.5	14.7	14.8	14.9	14.9
	60.0		15.8	15.9	16.0	16.3	16.5	16.6	16.7
	65.0			17.4	17.6	18.0	18.2	18.3	18.4

MassFlow(kg/h)

		Evaporating Temp. (°C)							
		-30	-20	-15	-10	0	7.2	10	12
Condensing Temp. (°C)	30	130.0	210.7	265.1	328.9	484.6	619.8	677.7	720.8
	35	130.2	205.6	257.9	319.8	472.6	606.6	664.2	707.1
	40.5	130.5	200.2	250.1	310.0	459.8	592.4	649.6	692.4
	45.0	130.7	195.9	243.9	302.2	449.5	581.1	638.0	680.6
	50.0	130.9	191.2	237.2	293.7	438.4	568.7	625.2	667.7
	54.4	131.1	187.2	231.5	286.5	428.8	558.0	614.3	656.5
	60.0		182.3	224.4	277.5	416.9	544.7	600.6	642.6
	65.0			218.3	269.8	406.6	533.1	588.6	630.5

EER

		Evaporating Temp. (°C)							
		-30	-20	-15	-10	0	7.2	10	12
Condensing Temp. (°C)	30	2.51	3.35	3.87	4.48	5.99	7.37	8.00	8.47
	35	2.35	3.09	3.55	4.08	5.38	6.56	7.09	7.49
	40.5	2.17	2.82	3.21	3.66	4.74	5.73	6.16	6.49
	45.0	2.04	2.61	2.95	3.34	4.28	5.12	5.48	5.76
	50.0		2.39	2.69	3.02	3.82	4.51	4.82	5.05
	54.4		2.22	2.47	2.77	3.45	4.05	4.31	4.50
	60.0			2.23	2.48	3.04	3.53	3.73	3.89
	65.0				2.25	2.72	3.13	3.30	3.43

Coefficients of Polynomial Formula

	Heating Capacity (W)	Input (W)	Current (A)	MassFlow (kg/h)
C1	2.999541E+04	3.445769E+03	6.098469E+00	5.630078E+02
C2	1.055011E+03	1.380994E+00	5.514149E-04	1.898175E+01
C3	-1.140366E+01	-4.038469E+00	3.235269E-02	-2.807415E+00
C4	1.505486E+01	-1.580165E-02	-3.491414E-05	1.539752E-01
C5	-6.866030E+00	-4.812797E-01	-6.136183E-04	-5.539983E-02
C6	1.057456E-01	1.824465E+00	2.299798E-03	6.226473E-03
C7	7.096918E-02	-1.612649E-04	-4.086582E-07	8.935001E-07
C8	-1.171038E-01	1.731347E-04	4.353584E-07	1.135602E-03
C9	5.579883E-03	1.228334E-02	1.800124E-05	1.419587E-04
C10	-5.328717E-08	1.851826E-07	2.864374E-10	-2.385911E-09

Note: The polynomial coefficients subject to change without notice.

$$X = C1 + C2*(S) + C3*D + C4*(S^2) + C5*(S*D) + C6*(D^2) + C7*(S^3) + C8*(D*S^2) + C9*(S*D^2) + C10*(D^3)$$

X—CAPACITY(W) OR POWER(W) OR CURRENT(A)

S—EVAPORATING TEMP, °C

D—CONDENSING TEMP, °C

WIRING DIAGRAM

C-SC Series 3 phase
5.8-9kw
European & Chinese
power supply
specifications
models

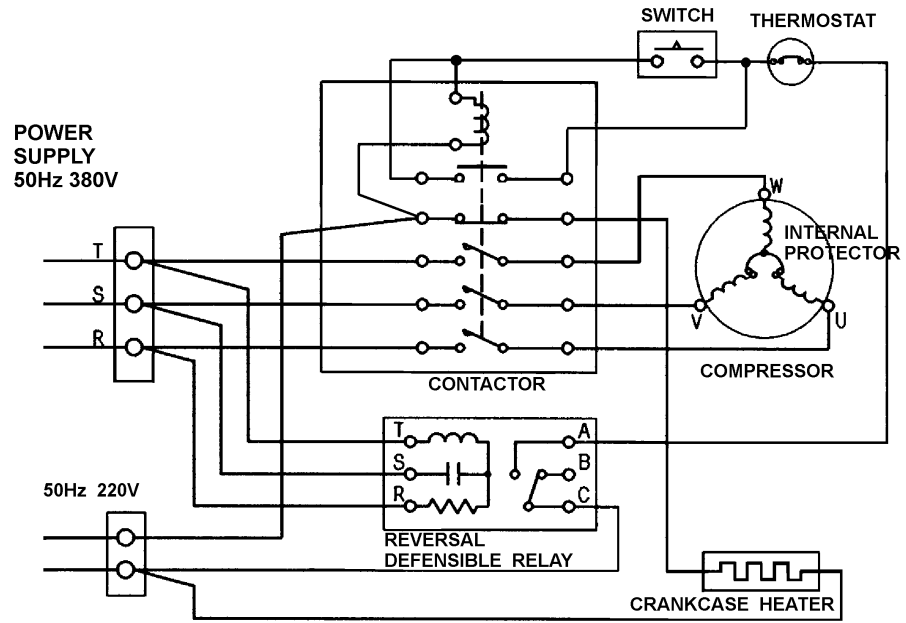

Operating Envelope

Suction Gas Superheat: 11.1K
Refrigerant: R407C

