

Model

Designation	NL6.1MF	220-240V/50Hz 1~ 208-230V/60Hz 1~	Sales code:	105G6660
-------------	----------------	------------------------------------------	-------------	-----------------

Compressor design

Oil type	Polyolester	Refrigerant(s)	R134a , R513A
Oil viscosity	19,2cST	Displacement	6,13cm ³ / 0,37cu.in
Oil quantity	270cm ³ / 9,1fl.oz	Compressors on pallet	80
Refr. charge - tech. limit	600g / 21,2oz		
Free gas volume comp.	2360cm ³ / 79,8fl.oz		
Weight	10kg / 22lbs		
Motor protection	1# internal		
Winding resistance main	10,2Ω (at 25°C)		
Winding resistance aux	16,4Ω (at 25°C)		
Max. winding temp.	125°C / 257°F		
Max. discharge temp.	130°C / 266°F		



General - Configurations with NL6.1MF

	Conf. 1	Conf. 2	Conf. 3	Conf. 4	Conf. 5
Motorconfiguration	RSIR	CSIR	CSIR	CSIR	CSIR
Power supply (nominal)	220-240V/50Hz	220-240V/50Hz	208-230V/60Hz	220-240V/50Hz	208-230V/60Hz
Number of phases	1	1	1	1	1
Voltage range	187-254V	187-254V	187-254V	187-254V	187-253V
Approvals	VDE, UL, CCC, EAC, KC	VDE, UL, CCC, EAC, KC	VDE, UL, CCC, EAC, KC	VDE, UL, CCC, EAC, KC	VDE, UL, CCC, EAC, KC
Starting torque	LST	HST	HST	HST	HST
Note	- / -				

Applications with NL6.1MF

	Conf. 1	Conf. 2	Conf. 3	Conf. 4	Conf. 5
Refrigerant	R134a	R134a	R134a	R513A	R513A
Application	MBP	MBP	LBP+MBP	MBP	LBP+MBP
System cooling	fan 1,5m/s	fan 1,5m/s	fan 1,5m/s	fan 1,5m/s	fan 1,5m/s
Hot gas defrost	- / -	- / -	- / -	- / -	- / -
Long interval pull down	OK	OK	OK	OK	OK

Electrical data - Configurations with NL6.1MF

	Conf. 1	Conf. 2	Conf. 3	Conf. 4	Conf. 5
Starting device type	PTC	relay	relay	relay	relay
Run capacitor	- / -	- / -	- / -	- / -	- / -
Start capacitor	- / -	80μF	80μF	80μF	80μF
LRA (locked rotor amps / 4s)	8A	9,2A	9,2A	9,2A	9,2A
RLA (rated load amps / 1s)	1,7A	1,7A	1,7A	1,7A	1,7A
Cut in current	12,2A	12,2A	12,2A	12,2A	12,2A

Model

Designation **NL6.1MF** 220-240V/50Hz 1~ 208-230V/60Hz 1~ Sales code: **105G6660**

Compressor dimensions

Housing	A Height	190,5mm / 7,5in
	B Height	184,5mm / 7,26in
	C Length shell	205mm / 8,07in
	D Length w. cover	254mm / 10in
	E Width	166mm / 6,54in

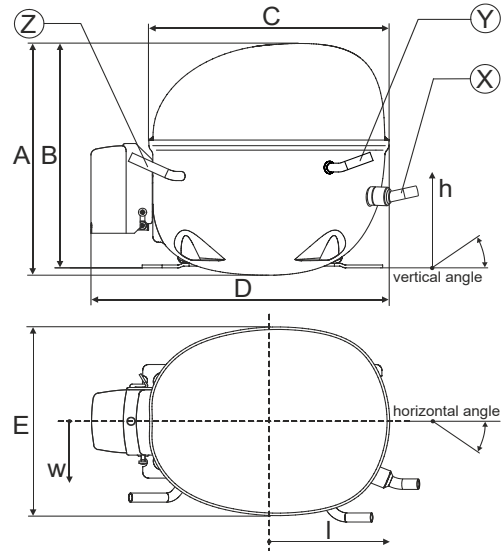

Connectors		Suction	Discharge	Process
		X	Y	Z
Diameter	[mm]	øi 8,11-8,29	øi 6,11-6,29	øi 6,11-6,29
(i:inside, o:outside)	[in]	øi 0,32-0,33	øi 0,24-0,25	øi 0,24-0,25
Material		copper	copper	copper
Horizontal angle	±2°	0°	0°	0°
Vertical angle	±2°	15°	35°	155°
Position l/h/w	[mm]	126/76/78	133/103/54	-107/94/72
	[in]	4,9/3/3,1	5,2/4/2,1	-4,2/3,7/2,8
Straight tube l.	[mm]	12	12	12
	[in]	0,5	0,5	0,5

Compressor fixation

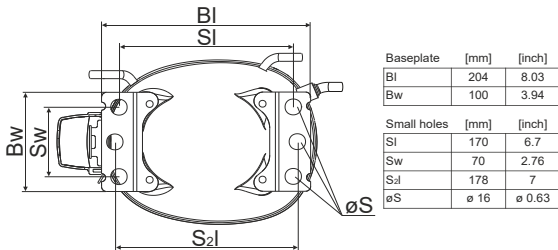

Bolt joint

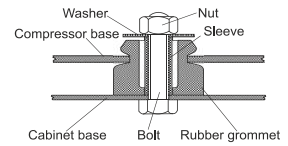

Snap-on

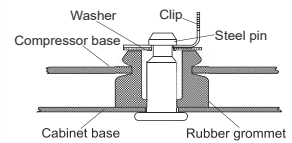

Mounting accessories	one comp.	multi pack
Bolt joint M6 ø16mm	118-1917	118-1918
Bolt joint ø1/4" ø16mm	118-1946	
Bolt joint ø1/4" ø19mm	118-1949	
Snap-on ø7,3 ø16mm	118-1947	118-1919

Application notes

LRA value on compressor label and datasheet may differ due to different test conditions for UL approval.

Model

Designation	NL6.1MF	220-240V/50Hz	Conf. 1	Sales code:	105G6660
-------------	----------------	----------------------	----------------	-------------	-----------------

Configuration

Motorconfiguration	RSIR
Power supply (nominal)	220-240V/50Hz 1~
Refrigerant	R134a
Application	MBP
Voltage range	187-254V
Starting torque	LST
Approvals	VDE (2)
(1): Made in China	UL (1),(2)
(2): Made in Slovakia	CCC (1),(2)
	EAC (1),(2)
	KC (1)

Electrical accessories / wiring diagram

RSIR

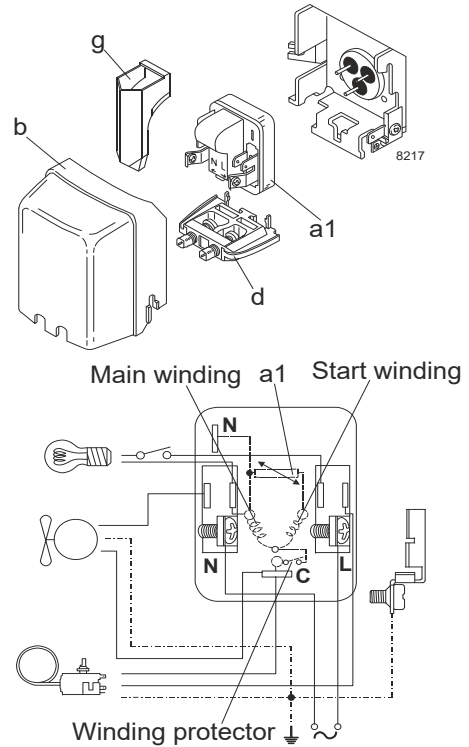

Ambient temperatures / system cooling

Ambient temperature min.:	10°C / 50°F
Ambient temperature max.:	43°C / 110°F

System cooling (n/a: outside limits)			
T ambient	LBP	MBP	HBP
32°C / 90°F	n/a	fan 1,5m/s	n/a
38°C / 100°F	n/a	fan 1,5m/s	n/a
43°C / 110°F	n/a	fan 1,5m/s	n/a

Operation pressure range

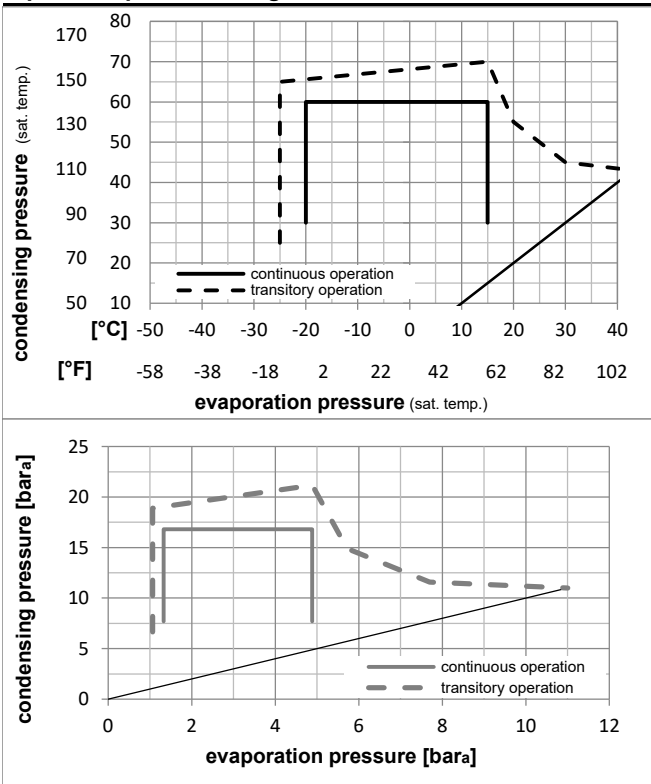

Components

a1	PTC starter (220V, 250hm, 4.8mm)	103N0018
b	plastic cover	103N2011
d	cord relief	103N1010
g	protection screen for PTC	103N0476

Alternative components

a1	PTC starter (220V, 250hm, 6.3mm)	103N0011
b	plastic cover	103N2011
d	cord relief	103N1010
g	protection screen for PTC	103N0476

Model

Designation **NL6.1MF 220-240V/50Hz** Conf. 1 Sales code: **105G6660**

Optimization + standard conditions

R134a, 220V/50Hz, RSIR, static, VDE, UL, CCC, EAC, KC

Evaporating pressure (saturation temperature)		Condensing pressure (saturation temperature)				Power consumption									ASHRAE MBP	
		Return gas temp.				Current consumption										Ref. mass flow ṁ
		Liquid temp.				Cooling capacity	COP	EER	P1	I		ṁ				
pe	pc	RGT	Tliq	[W]	[Btu/h]					[kcal/h]	[W/W]		[Btu/Wh]	[kcal/Wh]		
[°C]	-6,66	54,4	35	46,1	320,1	1093	275,5	1,61	5,49	1,38	199,2	1,46	6,98	ASHRAE MBP		
[°F]	20	130	95	115												
[°C]	-10	55	32	55	245,1	837	211,0	1,31	4,47	1,13	187,5	1,43	5,93	cecomaf MBP		
[°F]	14	131	89,6	131												
[°C]	-10	45	20	45	283,3	968	243,8	1,59	5,44	1,37	177,8	1,40	6,63	EN12900 MBP		
[°F]	14	113	68	113												
[°C]	-6,66	48,9	18,3	48,9	308,4	1053	265,4	1,60	5,46	1,38	192,9	1,44	7,62	ARI540 MBP		
[°F]	20	120	65	120												
[°C]	-10	45	32	45	293,9	1004	253,0	1,65	5,65	1,42	177,8	1,40	6,43	opt		
[°F]	14	113	89,6	113												
[°C]	-25	45	32	45	127,3	435	109,5	0,99	3,37	0,85	129,0	1,32	2,76	opt		
[°F]	-13	113	89,6	113												

Performance tables

R134a, 220V/50Hz, RSIR, static, VDE, UL, CCC, EAC, KC

	pe		Cooling capacity			COP		EER		P1	I	m
	[°C]	[°F]	[W]	[Btu/h]	[kcal/h]	[W/W]	[Btu/Wh]	[kcal/Wh]	[W]	[A]	[kg/h]	
[°C / °F]	-20	-4	173,3	592	149,1	1,19	4,06	1,02	145,8	1,34	3,76	
cond. pressure	-15	5	228,4	780	196,5	1,41	4,82	1,21	162,0	1,37	4,98	
pc= 45/113	-10	14	293,9	1004	253,0	1,65	5,65	1,42	177,8	1,40	6,43	
return gas temp.	-5	23	371,3	1268	319,5	1,92	6,56	1,65	193,4	1,44	8,16	
RGT= 32/90	0	32	461,8	1577	397,4	2,21	7,54	1,90	209,1	1,49	10,21	
liquid temp	5	41	566,7	1935	487,7	2,52	8,60	2,17	225,2	1,54	12,62	
Tliq= 45/113	15	59	825,4	2819	710,4	3,19	10,88	2,74	259,1	1,66	18,70	
[°C / °F]	-20	-4	140,8	481	121,2	0,94	3,21	0,81	149,8	1,35	3,38	
cond. pressure	-15	5	188,5	644	162,2	1,12	3,81	0,96	168,8	1,39	4,54	
pc= 55/131	-10	14	245,1	837	211,0	1,31	4,47	1,13	187,5	1,43	5,93	
return gas temp	-5	23	312,0	1066	268,5	1,51	5,17	1,30	206,0	1,48	7,58	
RGT= 32/90	0	32	390,5	1334	336,1	1,74	5,94	1,50	224,5	1,54	9,55	
liquid temp	5	41	481,9	1646	414,7	1,98	6,76	1,70	243,3	1,60	11,87	
Tliq= 55/131	15	59	708,9	2421	610,1	2,51	8,56	2,16	282,9	1,75	17,81	

Model

Designation	NL6.1MF	220-240V/50Hz	Conf. 2	Sales code:	105G6660
-------------	----------------	----------------------	----------------	-------------	-----------------

Configuration

Motorconfiguration	CSIR
Power supply (nominal)	220-240V/50Hz 1~
Refrigerant	R134a
Application	MBP
Voltage range	187-254V
Starting torque	HST
Approvals	VDE (2)
(1): Made in China	UL (1),(2)
(2): Made in Slovakia	CCC (1),(2)
	EAC (1),(2)
	KC (1)

Electrical accessories / wiring diagram

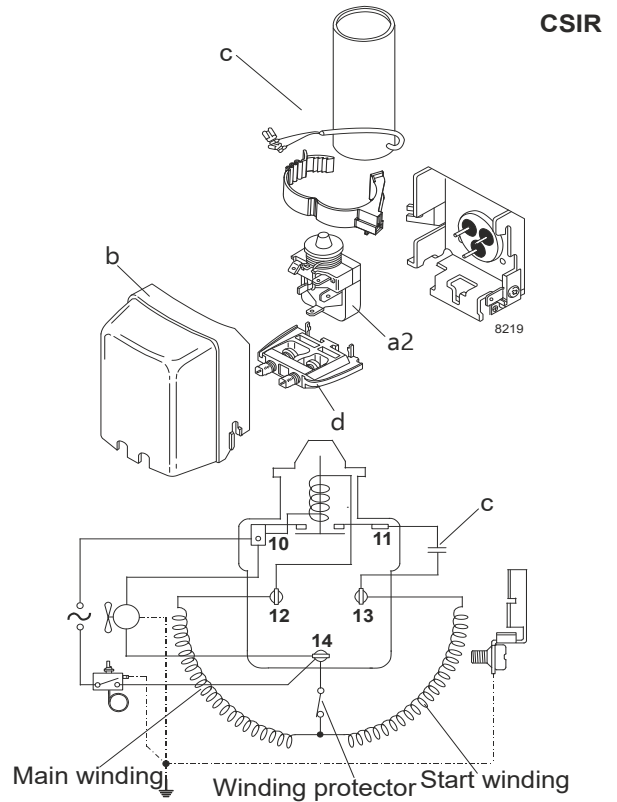

Ambient temperatures / system cooling

Ambient temperature min.:	10°C / 50°F
Ambient temperature max.:	43°C / 110°F

System cooling (n/a: outside limits)			
T ambient	LBP	MBP	HBP
32°C / 90°F	n/a	fan 1,5m/s	n/a
38°C / 100°F	n/a	fan 1,5m/s	n/a
43°C / 110°F	n/a	fan 1,5m/s	n/a

Operation pressure range

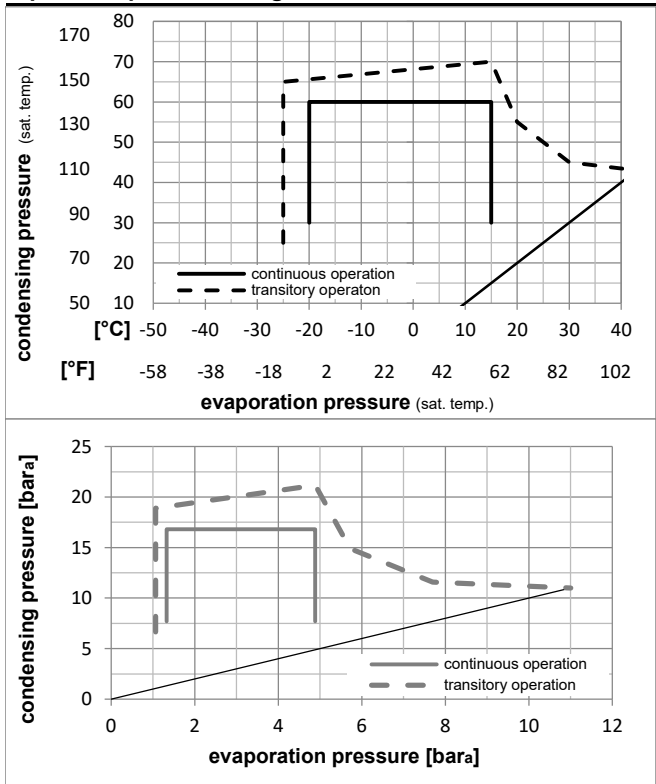

Components

a2	relay	117U6015
c	start capacitor (80µF)	117U5015
b	plastic cover	103N2011
d	cord relief	103N1010

Model

Designation **NL6.1MF 220-240V/50Hz** Conf. **2** Sales code: **105G6660**

Optimization + standard conditions

R134a, 220V/50Hz, CSIR, static, VDE, UL, CCC, EAC, KC

	Evaporating pressure (saturation temperature)				Condensing pressure (saturation temperature)						Power consumption			ASHRAE MBP
	pe	pc	RGT	Tliq	W	[Btu/h]	[kcal/h]	COP	EER	[kcal/Wh]	P1	I	m	
	[°C]	[°C]	[°C]	[°C]	[W]	[Btu/h]	[kcal/h]	[W/W]	[Btu/Wh]	[kcal/Wh]	[W]	[A]	[kg/h]	
	-6,7	54,4	35	46,1	320,1	1093	275,5	1,61	5,49	1,38	199,2	1,46	6,98	ASHRAE MBP
	[°F]	20	130	95	115									
	-10	55	32	55	245,1	837	211,0	1,31	4,47	1,13	187,5	1,43	5,93	cecmaf MBP
	[°F]	14	131	89,6	131									
	-10	45	20	45	283,3	968	243,8	1,59	5,44	1,37	177,8	1,40	6,63	EN12900 MBP
	[°F]	14	113	68	113									
	-6,7	48,9	18,3	48,9	308,4	1053	265,4	1,60	5,46	1,38	192,9	1,44	7,62	ARI540 MBP
	[°F]	20	120	65	120									
	-10	45	32	45	293,9	1004	253,0	1,65	5,65	1,42	177,8	1,40	6,43	opt
	[°F]	14	113	89,6	113									
	-25	45	32	45	127,3	435	109,5	0,99	3,37	0,85	129,0	1,32	2,76	opt
	[°F]	-13	113	89,6	113									

Performance tables

R134a, 220V/50Hz, CSIR, static, VDE, UL, CCC, EAC, KC

	pe	Cooling capacity			COP	EER	P1	I	m		
	[°C]	[°F]	[W]	[Btu/h]	[kcal/h]	[W/W]	[Btu/Wh]	[kcal/Wh]	[W]	[A]	[kg/h]
[°C / °F]	-20	-4	173,3	592	149,1	1,19	4,06	1,02	145,8	1,34	3,76
cond. pressure	-15	5	228,4	780	196,5	1,41	4,82	1,21	162,0	1,37	4,98
pc= 45/113	-10	14	293,9	1004	253,0	1,65	5,65	1,42	177,8	1,40	6,43
return gas temp.	-5	23	371,3	1268	319,5	1,92	6,56	1,65	193,4	1,44	8,16
RGT= 32/90	0	32	461,8	1577	397,4	2,21	7,54	1,90	209,1	1,49	10,21
liquid temp	5	41	566,7	1935	487,7	2,52	8,60	2,17	225,2	1,54	12,62
Tliq= 45/113	15	59	825,4	2819	710,4	3,19	10,88	2,74	259,1	1,66	18,70
[°C / °F]	-20	-4	140,8	481	121,2	0,94	3,21	0,81	149,8	1,35	3,38
cond. pressure	-15	5	188,5	644	162,2	1,12	3,81	0,96	168,8	1,39	4,54
pc= 55/131	-10	14	245,1	837	211,0	1,31	4,47	1,13	187,5	1,43	5,93
return gas temp	-5	23	312,0	1066	268,5	1,51	5,17	1,30	206,0	1,48	7,58
RGT= 32/90	0	32	390,5	1334	336,1	1,74	5,94	1,50	224,5	1,54	9,55
liquid temp	5	41	481,9	1646	414,7	1,98	6,76	1,70	243,3	1,60	11,87
Tliq= 55/131	15	59	708,9	2421	610,1	2,51	8,56	2,16	282,9	1,75	17,81

Model

Designation	NL6.1MF	208-230V/60Hz	Conf. 3	Sales code:	105G6660
-------------	----------------	----------------------	----------------	-------------	-----------------

Configuration

Motorconfiguration	CSIR
Power supply (nominal)	208-230V/60Hz 1~
Refrigerant	R134a
Application	LBP+MBP
Voltage range	187-254V
Starting torque	HST
Approvals	VDE (2)
(1): Made in China	UL (1),(2)
	CCC (1),(2)
	EAC (1),(2)
	KC (1)

Electrical accessories / wiring diagram

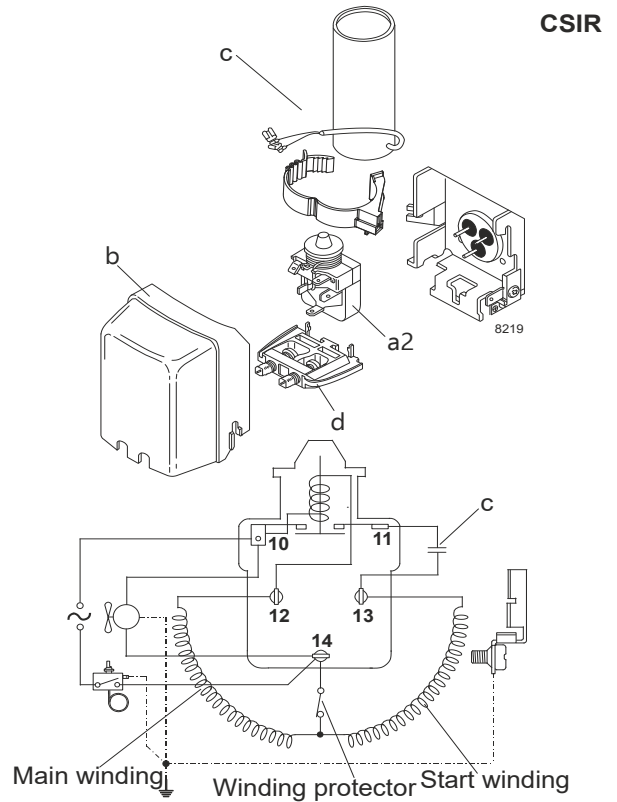

Ambient temperatures / system cooling

Ambient temperature min.:	10°C / 50°F
Ambient temperature max.:	43°C / 110°F

System cooling (n/a: outside limits)			
T ambient	LBP	MBP	HBP
32°C / 90°F	fan 1,5m/s	fan 1,5m/s	n/a
38°C / 100°F	fan 1,5m/s	fan 1,5m/s	n/a
43°C / 110°F	fan 1,5m/s	fan 1,5m/s	n/a

Operation pressure range

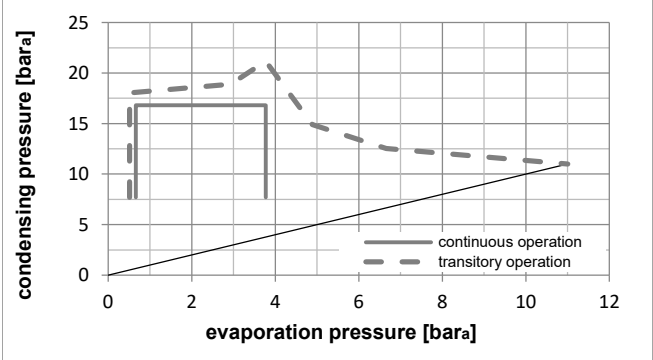
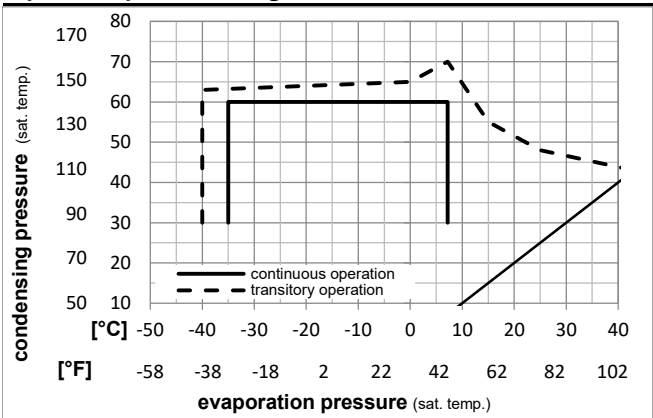

Components

a2	relay	117U6015
c	start capacitor (80µF)	117U5015
b	plastic cover	103N2011
d	cord relief	103N1010

Model

Designation **NL6.1MF 208-230V/60Hz** Conf. **3** Sales code: **105G6660**

Optimization + standard conditions

R134a, 220V/60Hz, CSIR, static, VDE, UL, CCC, EAC, KC

Evaporating pressure (saturation temperature)		Condensing pressure (saturation temperature)			Cooling capacity						Power consumption		Current consumption		Ref. mass flow	
pe	pc	RGT	Tliq	[W]	[Btu/h]	[kcal/h]	COP	EER	[W]	I	m	[A]	[kg/h]			
[°C]	[°C]	[°C]	[°C]	[W]	[Btu/h]	[kcal/h]	[W/W]	[Btu/Wh]	[kcal/Wh]	[W]	[A]	[kg/h]				
-6,66	54,4	35	46,1	383,3	1309	329,8	1,62	5,54	1,40	236,2	1,44	8,36	ASHRAE	MBP		
[°F]	20	130	95	115												
-10	55	32	55	292,1	998	251,4	1,34	4,58	1,16	217,6	1,37	7,06	cecomaf	MBP		
[°F]	14	131	89,6	131												
-10	45	20	45	339,2	1159	291,9	1,65	5,64	1,42	205,4	1,33	7,94	EN12900	MBP		
[°F]	14	113	68	113												
-6,66	48,9	18,3	48,9	370,8	1266	319,1	1,63	5,57	1,40	227,2	1,41	9,16	ARI540	MBP		
[°F]	20	120	65	120												
-10	45	32	45	351,9	1202	302,9	1,71	5,85	1,47	205,4	1,33	7,70	opt			
[°F]	14	113	89,6	113												
-25	45	32	45	152,2	520	130,9	1,13	3,87	0,98	134,3	1,09	3,30	opt			
[°F]	-13	113	89,6	113												

Performance tables

R134a, 220V/60Hz, CSIR, static, VDE, UL, CCC, EAC, KC

	pe		Cooling capacity			COP		EER		P1		I		m	
	[°C]	[°F]	[W]	[Btu/h]	[kcal/h]	[W/W]	[Btu/Wh]	[kcal/Wh]	[W]	[A]	[kg/h]				
[°C / °F]	-35	-31	70,6	241	60,7	0,79	2,71	0,68	89,0	0,96	1,52				
cond. pressure	-25	-13	152,2	520	130,9	1,13	3,87	0,98	134,3	1,09	3,30				
pc= 45/113	-15	5	272,9	932	234,9	1,50	5,14	1,29	181,4	1,24	5,95				
return gas temp.	-10	14	351,9	1202	302,9	1,71	5,85	1,47	205,4	1,33	7,70				
RGT= 32/90	-5	23	445,5	1521	383,4	1,94	6,63	1,67	229,6	1,42	9,80				
liquid temp	0	32	555,0	1896	477,7	2,19	7,47	1,88	253,7	1,52	12,27				
Tliq= 45/113	7,2	45	744,2	2542	640,5	2,58	8,82	2,22	288,1	1,68	16,62				
[°C / °F]	-35	-31	42,9	146	36,9	0,55	1,88	0,47	77,9	0,91	1,02				
cond. pressure	-25	-13	117,0	400	100,7	0,89	3,03	0,76	132,0	1,08	2,80				
pc= 55/131	-15	5	223,1	762	192,0	1,18	4,04	1,02	188,7	1,26	5,37				
return gas temp	-10	14	292,1	998	251,4	1,34	4,58	1,16	217,6	1,37	7,06				
RGT= 32/90	-5	23	373,8	1276	321,7	1,51	5,17	1,30	246,9	1,48	9,09				
liquid temp	0	32	469,7	1604	404,2	1,70	5,81	1,46	276,3	1,60	11,49				
Tliq= 55/131	7,2	45	636,0	2172	547,4	2,00	6,82	1,72	318,6	1,78	15,73				

Model

Designation	NL6.1MF	220-240V/50Hz	Conf. 4	Sales code:	105G6660
-------------	----------------	----------------------	----------------	-------------	-----------------

Configuration

Motorconfiguration	CSIR
Power supply (nominal)	220-240V/50Hz 1~
Refrigerant	R513A
Application	MBP
Voltage range	187-254V
Starting torque	HST
Approvals	VDE (2)
(1): Made in China	UL (1),(2)
(2): Made in Slovakia	CCC (1),(2)
	EAC (1),(2)
	KC (1)

Electrical accessories / wiring diagram

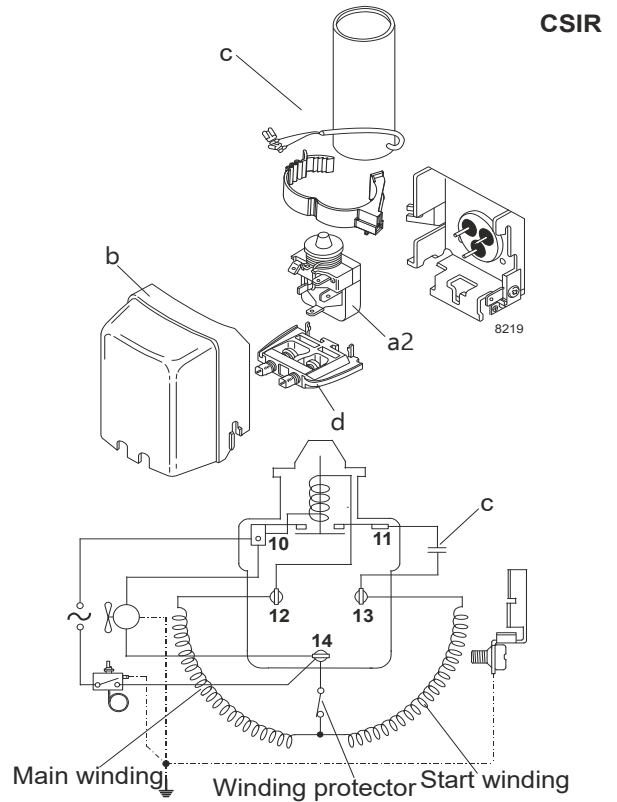

Ambient temperatures / system cooling

Ambient temperature min.:	10°C / 50°F
Ambient temperature max.:	43°C / 110°F

System cooling (n/a: outside limits)			
T ambient	LBP	MBP	HBP
32°C / 90°F	n/a	fan 1,5m/s	n/a
38°C / 100°F	n/a	fan 1,5m/s	n/a
43°C / 110°F	n/a	fan 1,5m/s	n/a

Operation pressure range

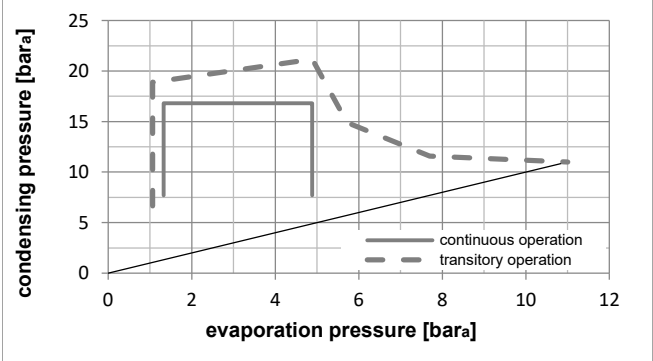
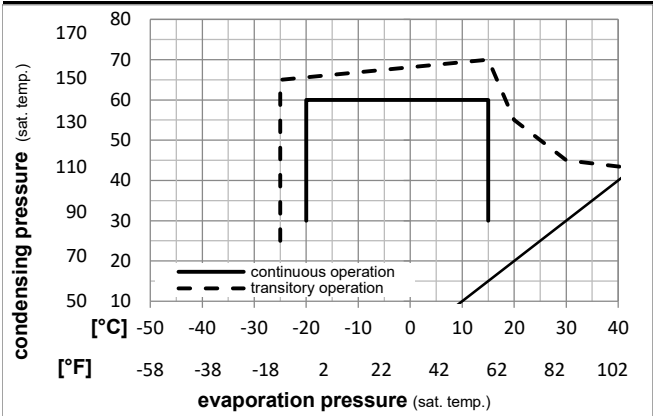

Components

a2	relay	117U6015
c	start capacitor (80µF)	117U5015
b	plastic cover	103N2011
d	cord relief	103N1010

Model

Designation **NL6.1MF 220-240V/50Hz** Conf. **4** Sales code: **105G6660**

Optimization + standard conditions

R513A, 220V/50Hz, CSIR, static, VDE, UL, CCC, EAC, KC

	Evaporating pressure (saturation temperature)				Condensing pressure (saturation temperature)						Power consumption			ASHRAE MBP				
	pe	pc	RGT	Tliq	W	[Btu/h]	[kcal/h]	COP	EER	[kcal/Wh]	P1	I	Ref. mass flow m					
	[°C]	[°F]	[°C]	[°F]	[W]	[Btu/h]	[kcal/h]	[W/W]	[Btu/Wh]	[kcal/Wh]	[W]	[A]	[kg/h]					
	-6,66	20	54,4	130	35	95	46,1	115	336,7	1150	289,8	1,59	5,45	1,37	211,1	1,50	8,25	ASHRAE MBP
	-10	14	55	131	32	89,6	55	131	254,9	871	219,4	1,28	4,36	1,10	199,5	1,47	7,05	cecomaf MBP
	-10	14	45	113	20	68	45	113	296,6	1013	255,3	1,57	5,37	1,35	188,6	1,45	7,86	EN12900 MBP
	-6,66	20	48,9	120	18,3	65	48,9	120	318,7	1089	274,3	1,56	5,33	1,34	204,1	1,49	8,98	ARI540 MBP
	-10	14	45	113	32	89,6	45	113	310,2	1059	266,9	1,64	5,62	1,42	188,6	1,45	7,63	opt
	-25	-13	45	113	32	89,6	45	113	139,2	476	119,8	1,00	3,41	0,86	139,5	1,32	3,39	opt

Performance tables

R513A, 220V/50Hz, CSIR, static, VDE, UL, CCC, EAC, KC

	pe	Cooling capacity			COP	EER	P1	I	m		
	[°C]	[°F]	[W]	[Btu/h]	[kcal/h]	[W/W]	[Btu/Wh]	[kcal/Wh]	[W]	[A]	[kg/h]
[°C / °F]	-20	-4	186,9	638	160,8	1,19	4,08	1,03	156,5	1,37	4,57
cond. pressure	-15	5	243,4	831	209,5	1,41	4,81	1,21	172,7	1,41	5,96
pc= 45/113	-10	14	310,2	1059	266,9	1,64	5,62	1,42	188,6	1,45	7,63
return gas temp.	-5	23	388,4	1326	334,3	1,90	6,50	1,64	204,2	1,49	9,59
RGT= 32/90	0	32	479,3	1637	412,5	2,18	7,45	1,88	219,8	1,52	11,89
liquid temp	5	41	584,3	1995	502,9	2,48	8,47	2,13	235,6	1,56	14,57
Tliq= 45/113	15	59	841,2	2873	724,0	3,13	10,69	2,69	268,7	1,65	21,28
[°C / °F]	-20	-4	150,2	513	129,3	0,93	3,17	0,80	161,7	1,38	4,12
cond. pressure	-15	5	198,3	677	170,7	1,10	3,74	0,94	180,9	1,43	5,46
pc= 55/131	-10	14	254,9	871	219,4	1,28	4,36	1,10	199,5	1,47	7,05
return gas temp	-5	23	321,4	1098	276,6	1,47	5,04	1,27	217,9	1,52	8,93
RGT= 32/90	0	32	398,9	1362	343,3	1,69	5,77	1,45	236,3	1,57	11,14
liquid temp	5	41	488,7	1669	420,6	1,92	6,55	1,65	254,8	1,61	13,73
Tliq= 55/131	15	59	710,3	2426	611,3	2,42	8,27	2,08	293,3	1,71	20,29

Model

Designation	NL6.1MF	208-230V/60Hz	Conf. 5	Sales code:	105G6660
-------------	----------------	----------------------	----------------	-------------	-----------------

Configuration

Motorconfiguration	CSIR
Power supply (nominal)	208-230V/60Hz 1~
Refrigerant	R513A
Application	LBP+MBP
Voltage range	187-253V
Starting torque	HST
Approvals	VDE (2)
(1): Made in China	UL (1),(2)
(2): Made in Slovakia	CCC (1),(2)
	EAC (1),(2)
	KC (1)

Electrical accessories / wiring diagram

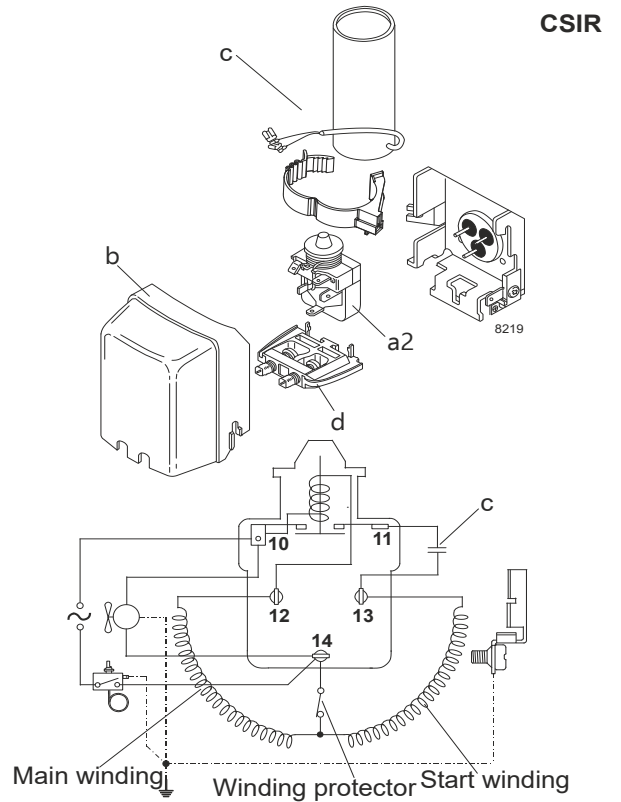

Ambient temperatures / system cooling

Ambient temperature min.:	10°C / 50°F
Ambient temperature max.:	43°C / 110°F

System cooling (n/a: outside limits)			
T ambient	LBP	MBP	HBP
32°C / 90°F	fan 1,5m/s	fan 1,5m/s	n/a
38°C / 100°F	fan 1,5m/s	fan 1,5m/s	n/a
43°C / 110°F	fan 1,5m/s	fan 1,5m/s	n/a

Operation pressure range

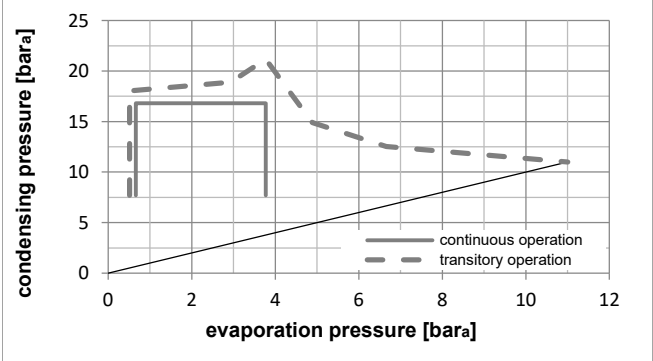
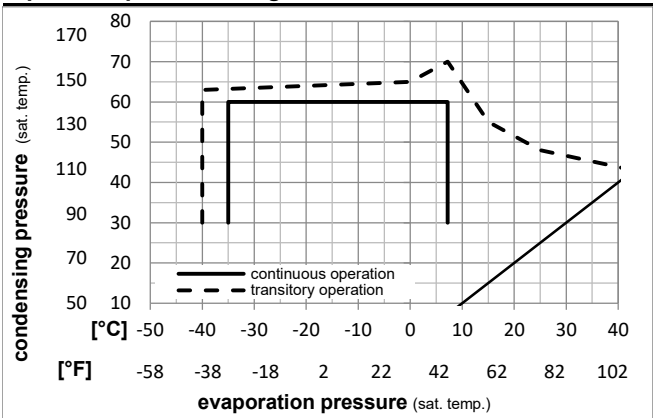

Components

a2	relay	117U6015
c	start capacitor (80µF)	117U5015
b	plastic cover	103N2011
d	cord relief	103N1010

Model

Designation **NL6.1MF 208-230V/60Hz** Conf. **5** Sales code: **105G6660**

Optimization + standard conditions

R513A, 220V/60Hz, CSIR, static, VDE, UL, CCC, EAC, KC

Evaporating pressure (saturation temperature)		Condensing pressure (saturation temperature)			Return gas temp.		Liquid temp.		Cooling capacity	COP	EER	Power consumption		Ref. mass flow		
pe	pc	RGT	Tliq	[W]	[Btu/h]	[kcal/h]	[W/W]	[Btu/Wh]				[kcal/Wh]	P1			I
[°C]	[°F]	[°C]	[°F]	[W]	[Btu/h]	[kcal/h]	[W/W]	[Btu/Wh]	[kcal/Wh]	[W]	[A]	[kg/h]				
-6,66	20	54,4	130	35	46,1	115	403,1	1377	346,9	1,61	5,49	1,38	250,7	1,51	9,87	ASHRAE MBP
-10	14	55	131	32	55	131	303,8	1038	261,5	1,31	4,47	1,13	231,9	1,44	8,40	cecomaf MBP
-10	14	45	113	20	45	113	355,2	1213	305,7	1,63	5,56	1,40	218,3	1,39	9,41	EN12900 MBP
-6,66	20	48,9	120	18,3	48,9	120	383,3	1309	329,9	1,59	5,44	1,37	240,7	1,47	10,80	ARI540 MBP
-10	14	45	113	32	45	113	371,4	1269	319,7	1,70	5,81	1,46	218,3	1,39	9,13	opt
-25	-13	45	113	32	45	113	166,5	569	143,3	1,15	3,92	0,99	145,0	1,11	4,06	opt

Performance tables

R513A, 220V/60Hz, CSIR, static, VDE, UL, CCC, EAC, KC

	pe		Cooling capacity			COP		EER		P1		I		m	
	[°C]	[°F]	[W]	[Btu/h]	[kcal/h]	[W/W]	[Btu/Wh]	[kcal/Wh]	[W]	[A]	[kg/h]				
[°C / °F]	-35	-31	81,0	277	69,7	0,84	2,85	0,72	96,9	0,93	1,97				
cond. pressure	-25	-13	166,5	569	143,3	1,15	3,92	0,99	145,0	1,11	4,06				
pc= 45/113	-15	5	291,0	994	250,4	1,50	5,13	1,29	193,8	1,29	7,13				
return gas temp.	-10	14	371,4	1269	319,7	1,70	5,81	1,46	218,3	1,39	9,13				
RGT= 32/90	-5	23	466,0	1592	401,1	1,92	6,56	1,65	242,6	1,48	11,50				
liquid temp	0	32	576,2	1968	495,9	2,16	7,38	1,86	266,8	1,57	14,29				
Tliq= 45/113	7,2	45	765,2	2613	658,5	2,54	8,68	2,19	301,1	1,70	19,14				
[°C / °F]	-35	-31	50,3	172	43,3	0,58	1,99	0,50	86,2	0,88	1,37				
cond. pressure	-25	-13	127,1	434	109,4	0,88	3,02	0,76	143,6	1,10	3,48				
pc= 55/131	-15	5	234,8	802	202,0	1,16	3,96	1,00	202,3	1,33	6,47				
return gas temp	-10	14	303,8	1038	261,5	1,31	4,47	1,13	231,9	1,44	8,40				
RGT= 32/90	-5	23	385,0	1315	331,3	1,47	5,03	1,27	261,6	1,55	10,69				
liquid temp	0	32	479,8	1639	412,9	1,65	5,63	1,42	291,1	1,66	13,40				
Tliq= 55/131	7,2	45	643,1	2196	553,4	1,93	6,59	1,66	333,4	1,82	18,13				