

Model

Designation	NLE12.6MN	220-240V/50Hz 1~	Sales code:	105H6377
-------------	------------------	-------------------------	-------------	-----------------

Compressor design

Oil type	Polyolester	Refrigerant(s)	R290
Oil viscosity	32cSt	Displacement	12,55cm ³ / 0,77cu.in
Oil quantity	300cm ³ / 10,1fl.oz	Compressors on pallet	80
Refr. charge - tech. limit	150g / 5,3oz		
Free gas volume comp.	2360cm ³ / 79,8fl.oz		
Weight	12,1kg / 26,7lbs		
Motor protection	1# internal		
Winding resistance main	4,74Ω (at 25°C)		
Winding resistance aux	7,92Ω (at 25°C)		
Max. winding temp.	125°C / 257°F		
Max. discharge temp.	130°C / 266°F		



General - Configurations with NLE12.6MN

	Conf. 1	Conf. 2	Conf. 3
Motorconfiguration	CSIR	RSIR	RSCR
Power supply (nominal)	220-240V/50Hz	220-240V/50Hz	220-240V/50Hz
Number of phases	1	1	1
Voltage range	198-254V	198-254V	198-254V
Approvals	VDE, CCC, EAC	VDE, CCC, EAC	VDE, CCC, EAC
Starting torque	HST	LST	LST
Note	- / -		

Applications with NLE12.6MN

	Conf. 1	Conf. 2	Conf. 3
Refrigerant	R290	R290	R290
Application	MBP	MBP	MBP
System cooling	fan 3m/s	fan 3m/s	fan 3m/s
Hot gas defrost	OK	OK	OK
Long interval pull down	OK	OK	OK

Electrical data - Configurations with NLE12.6MN

	Conf. 1	Conf. 2	Conf. 3
Starting device type	relay	PTC	PTC
Run capacitor	-/-	-/-	4μF
Start capacitor	80μF	-/-	-/-
LRA (locked rotor amps / 4s)	14,4A	15,1A	15,1A
RLA (rated load amps / 1s)	2,98A	2,98A	2,64A
Cut in current	14,4A	16,93A	16,93A
IP class	21	21	21

Model

Designation **NLE12.6MN** 220-240V/50Hz 1~ Sales code: **105H6377**

Compressor dimensions

Housing	A Height	203mm / 7,99in
	B Height	197mm / 7,76in
	C Length shell	205mm / 8,07in
	D Length w. cover	254mm / 10in
	E Width	166mm / 6,54in

Connectors		Suction	Discharge	Process
		X	Y	Z
Diameter	[mm]	øi 8,11-8,29	øi 6,11-6,29	øi 6,11-6,29
(i:inside, o:outside)	[in]	øi 0,32-0,33	øi 0,24-0,25	øi 0,24-0,25
Material		copper	copper	copper
Horizontal angle	±2°	0°	0°	0°
Vertical angle	±2°	15°	21°	155°
Position l/h/w	[mm]	132/69/56	94/99/86	-111/92/72
	[in]	5,2/2,7/2,2	3,7/3,9/3,4	-4,4/3,6/2,8
Straight tube l.	[mm]	12	12	12
	[in]	0,5	0,5	0,5

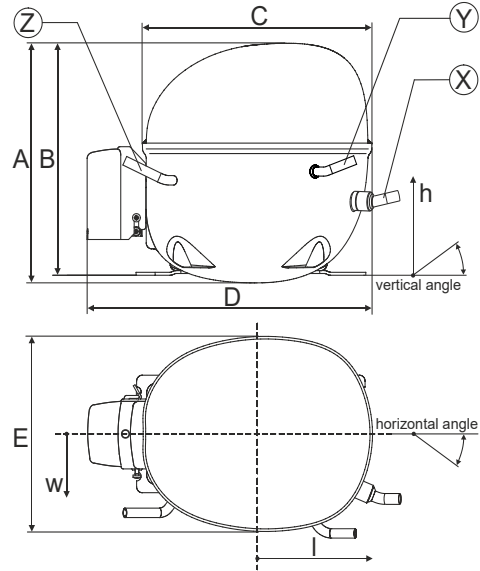

Compressor fixation

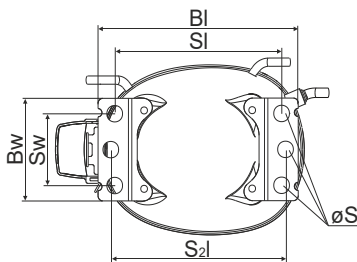

Baseplate	[mm]	[inch]
BI	204	8.03
BW	100	3.94
Small holes		
SI	170	6.7
SW	70	2.76
S2l	178	7
øS	ø 16	ø 0.63

Bolt joint

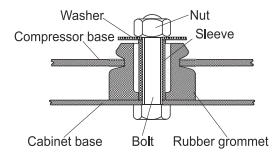

Snap-on

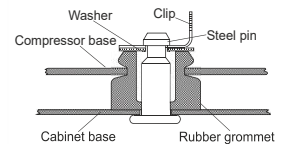

Mounting accessories

	one comp.	multi pack
Bolt joint M6 ø16mm	118-1917	118-1918
Bolt joint ø1/4" ø16mm	118-1946	
Snap-on ø7,3 ø16mm	118-1947	118-1919

Model

Designation	NLE12.6MN 220-240V/50Hz	Conf. 1	Sales code:	105H6377
-------------	--------------------------------	----------------	-------------	-----------------

Configuration

Motorconfiguration	CSIR
Power supply (nominal)	220-240V/50Hz 1~
Refrigerant	R290
Application	MBP
Voltage range	198-254V
Starting torque	HST
Approvals	VDE CCC EAC

Electrical accessories / wiring diagram

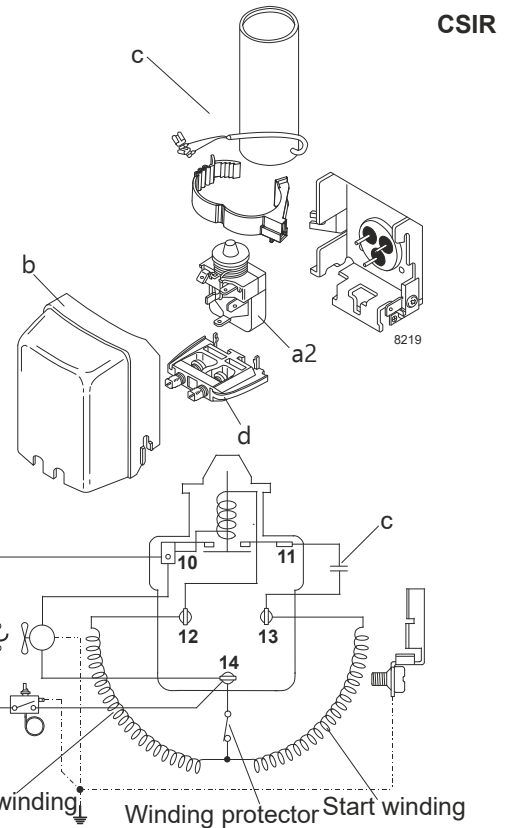

Ambient temperatures / system cooling

Ambient temperature min.:	10°C / 50°F
Ambient temperature max.:	43°C / 110°F

System cooling (n/a: outside limits)			
T ambient	LBP	MBP	HBP
32°C / 90°F	n/a	fan 3m/s	n/a
38°C / 100°F	n/a	fan 3m/s	n/a
43°C / 110°F	n/a	fan 3m/s	n/a

Operation pressure range

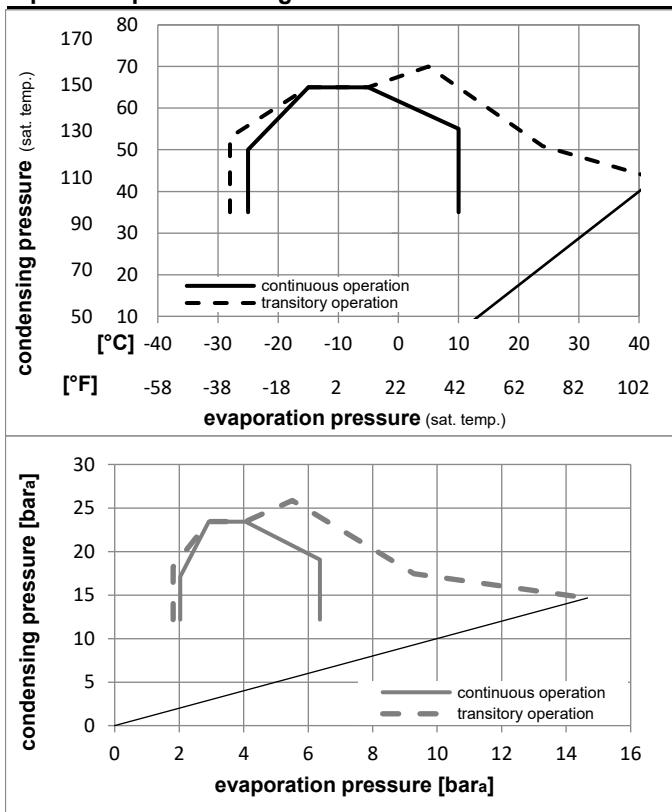

Components

a2	relay	117U7011
c	start capacitor (80µF)	117U5015
b	plastic cover	103N2010
d	cord relief	103N1010

Alternative components

b	plastic cover	103N2011
---	---------------	----------

Model

Designation **NLE12.6MN 220-240V/50Hz** Conf. 1 Sales code: **105H6377**

Optimization + standard conditions

220-240V/50Hz 1~, CSIR, fan 3m/s, VDE, CCC, EAC

	Evaporating pressure (saturation temperature)				Condensing pressure (saturation temperature)						Power consumption			ASHRAE MBP				
	pe	pc	RGT	Tliq	Cooling capacity			COP	EER	P1	I	Ref. mass flow						
	[°C]	[°F]	[°C]	[°F]	[W]	[Btu/h]	[kcal/h]	[W/W]	[Btu/Wh]	[kcal/Wh]	[W]	[A]	[kg/h]					
	-6,66	20	54,4	130	35	95	46,1	115	1060,9	3623	913,0	1,97	6,74	1,70	537,5	3,10	12,10	ASHRAE MBP
	-10	14	55	131	32	89,6	55	131	842,6	2878	725,2	1,66	5,67	1,43	507,7	2,99	10,66	cecomaf MBP
	-10	14	45	113	20	68	45	113	949,0	3241	816,7	2,05	7,01	1,77	462,3	2,77	11,65	EN12900 MBP
	-6,66	20	48,9	120	18,3	65	48,9	120	1004,0	3429	864,0	1,98	6,76	1,70	506,9	2,95	13,04	ARI540 MBP
	-10	14	45	113	32	89,6	45	113	987,9	3374	850,2	2,14	7,30	1,84	462,3	2,77	11,30	opt
	-25	-13	45	113	32	89,6	45	113	536,2	1831	461,5	1,53	5,21	1,31	351,5	2,41	6,05	opt

Performance tables

220-240V/50Hz 1~, CSIR, fan 3m/s, VDE, CCC, EAC

	pe	Cooling capacity			COP	EER	P1	I	m		
	[°C]	[°F]	[W]	[Btu/h]	[kcal/h]	[W/W]	[Btu/Wh]	[kcal/Wh]	[W]	[A]	[kg/h]
[°C / °F]	-25	-13	536,2	1831	461,5	1,53	5,21	1,31	351,5	2,41	6,05
cond. pressure	-20	-4	663,0	2264	570,5	1,71	5,84	1,47	387,9	2,52	7,51
pc= 45/113	-15	5	813,0	2776	699,6	1,91	6,53	1,65	425,1	2,65	9,25
return gas temp.	-10	14	987,9	3374	850,2	2,14	7,30	1,84	462,3	2,77	11,30
RGT= 32/90	0	32	1419,6	4848	1221,7	2,66	9,07	2,29	534,6	3,06	16,47
liquid temp	5	41	1679,8	5737	1445,6	2,96	10,09	2,54	568,4	3,22	19,65
Tliq= 45/113	10	50	1971,8	6734	1696,9	3,29	11,23	2,83	599,9	3,39	23,30
[°C / °F]	-25	-13	451,6	1542	388,7	1,21	4,14	1,04	372,6	2,49	5,62
cond. pressure	-20	-4	561,6	1918	483,4	1,35	4,62	1,17	414,9	2,64	7,02
pc= 55/131	-15	5	691,4	2361	595,0	1,50	5,13	1,29	460,1	2,81	8,69
return gas temp	-10	14	842,6	2878	725,2	1,66	5,67	1,43	507,7	2,99	10,66
RGT= 32/90	0	32	1216,3	4154	1046,8	2,00	6,84	1,72	607,6	3,39	15,62
liquid temp	5	41	1442,2	4925	1241,2	2,19	7,48	1,88	658,7	3,61	18,70
Tliq= 55/131	10	50	1696,5	5794	1460,0	2,39	8,16	2,06	709,7	3,85	22,24

Model

Designation	NLE12.6MN 220-240V/50Hz	Conf. 2	Sales code:	105H6377
-------------	--------------------------------	----------------	-------------	-----------------

Configuration

Motorconfiguration	RSIR
Power supply (nominal)	220-240V/50Hz 1~
Refrigerant	R290
Application	MBP
Voltage range	198-254V
Starting torque	LST
Approvals	VDE
	CCC
	EAC

Electrical accessories / wiring diagram

RSIR

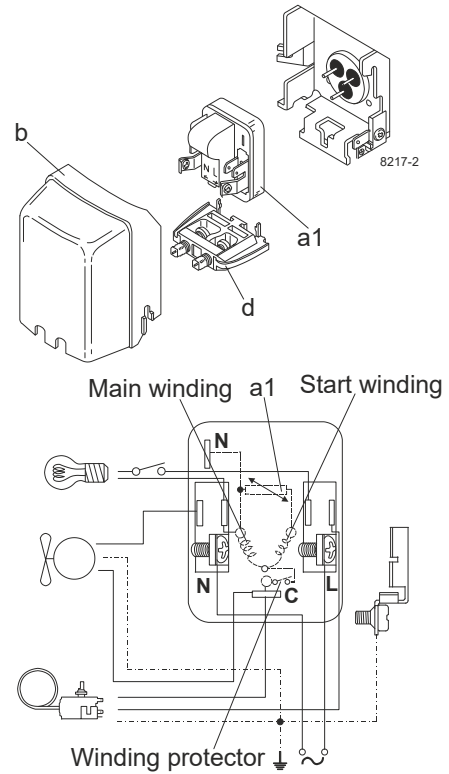

Ambient temperatures / system cooling

Ambient temperature min.:	10°C / 50°F
Ambient temperature max.:	43°C / 110°F

System cooling (n/a: outside limits)			
T ambient	LBP	MBP	HBP
32°C / 90°F	n/a	fan 3m/s	n/a
38°C / 100°F	n/a	fan 3m/s	n/a
43°C / 110°F	n/a	fan 3m/s	n/a

Operation pressure range

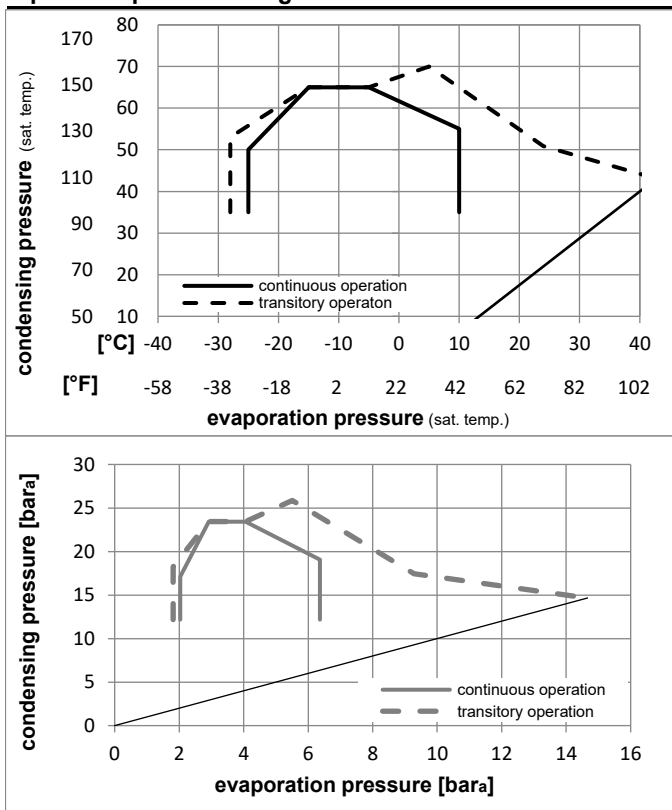

Components

a1	e-PTC starter (220V, 250hm, 4.8mm)	103N0050
b	plastic cover	103N2010
d	cord relief	103N1010

Alternative components

b	plastic cover	103N2011
---	---------------	----------

Model

Designation **NLE12.6MN 220-240V/50Hz** Conf. **2** Sales code: **105H6377**

Optimization + standard conditions

220-240V/50Hz 1~, RSIR, fan 3m/s, VDE, CCC, EAC

	Evaporating pressure (saturation temperature)				Condensing pressure (saturation temperature)						Power consumption			ASHRAE MBP				
	pe	pc	RGT	Tliq	Cooling capacity			COP	EER	P1	I	Ref. mass flow						
	[°C]	[°F]	[°C]	[°F]	[W]	[Btu/h]	[kcal/h]	[W/W]	[Btu/Wh]	[kcal/Wh]	[W]	[A]	[kg/h]					
	-6,66	20	54,4	130	35	95	46,1	115	1060,9	3623	913,0	1,97	6,74	1,70	537,5	3,10	12,10	ASHRAE MBP
	-10	14	55	131	32	89,6	55	131	842,6	2878	725,2	1,66	5,67	1,43	507,7	2,99	10,66	cecomaf MBP
	-10	14	45	113	20	68	45	113	949,0	3241	816,7	2,05	7,01	1,77	462,3	2,77	11,65	EN12900 MBP
	-6,66	20	48,9	120	18,3	65	48,9	120	1004,0	3429	864,0	1,98	6,76	1,70	506,9	2,95	13,04	ARI540 MBP
	-10	14	45	113	32	89,6	45	113	987,9	3374	850,2	2,14	7,30	1,84	462,3	2,77	11,30	opt
	-25	-13	45	113	32	89,6	45	113	536,2	1831	461,5	1,53	5,21	1,31	351,5	2,41	6,05	opt

Performance tables

220-240V/50Hz 1~, RSIR, fan 3m/s, VDE, CCC, EAC

	pe	Cooling capacity			COP	EER	P1	I	m		
	[°C]	[°F]	[W]	[Btu/h]	[kcal/h]	[W/W]	[Btu/Wh]	[kcal/Wh]	[W]	[A]	[kg/h]
[°C / °F]	-25	-13	536,2	1831	461,5	1,53	5,21	1,31	351,5	2,41	6,05
cond. pressure	-20	-4	663,0	2264	570,5	1,71	5,84	1,47	387,9	2,52	7,51
pc= 45/113	-15	5	813,0	2776	699,6	1,91	6,53	1,65	425,1	2,65	9,25
return gas temp.	-10	14	987,9	3374	850,2	2,14	7,30	1,84	462,3	2,77	11,30
RGT= 32/90	0	32	1419,6	4848	1221,7	2,66	9,07	2,29	534,6	3,06	16,47
liquid temp	5	41	1679,8	5737	1445,6	2,96	10,09	2,54	568,4	3,22	19,65
Tliq= 45/113	10	50	1971,8	6734	1696,9	3,29	11,23	2,83	599,9	3,39	23,30
[°C / °F]	-25	-13	451,6	1542	388,7	1,21	4,14	1,04	372,6	2,49	5,62
cond. pressure	-20	-4	561,6	1918	483,4	1,35	4,62	1,17	414,9	2,64	7,02
pc= 55/131	-15	5	691,4	2361	595,0	1,50	5,13	1,29	460,1	2,81	8,69
return gas temp	-10	14	842,6	2878	725,2	1,66	5,67	1,43	507,7	2,99	10,66
RGT= 32/90	0	32	1216,3	4154	1046,8	2,00	6,84	1,72	607,6	3,39	15,62
liquid temp	5	41	1442,2	4925	1241,2	2,19	7,48	1,88	658,7	3,61	18,70
Tliq= 55/131	10	50	1696,5	5794	1460,0	2,39	8,16	2,06	709,7	3,85	22,24

Model

Designation	NLE12.6MN	220-240V/50Hz	Conf. 3	Sales code:	105H6377
-------------	------------------	----------------------	----------------	-------------	-----------------

Configuration

Motorconfiguration	RSCR
Power supply (nominal)	220-240V/50Hz 1~
Refrigerant	R290
Application	MBP
Voltage range	198-254V
Starting torque	LST
Approvals	VDE
	CCC
	EAC

Electrical accessories / wiring diagram

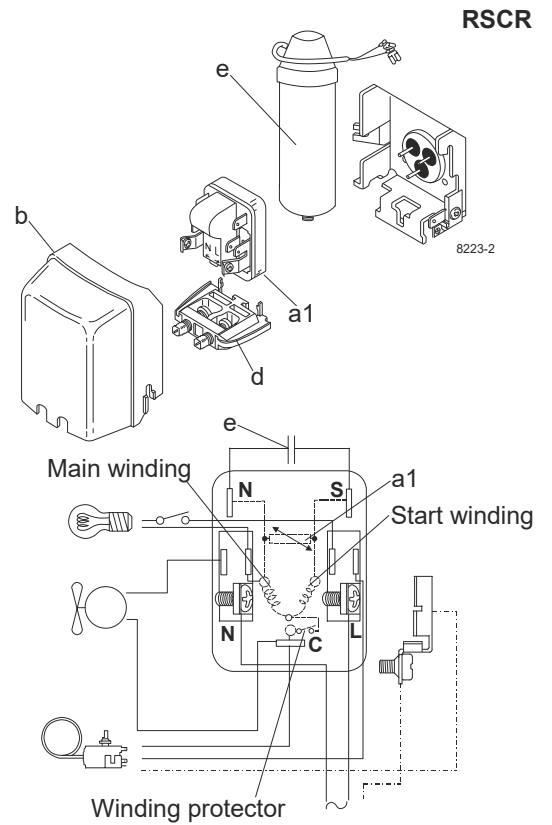

Ambient temperatures / system cooling

Ambient temperature min.:	10°C / 50°F
Ambient temperature max.:	43°C / 110°F

System cooling (n/a: outside limits)			
T ambient	LBP	MBP	HBP
32°C / 90°F	n/a	fan 3m/s	n/a
38°C / 100°F	n/a	fan 3m/s	n/a
43°C / 110°F	n/a	fan 3m/s	n/a

Operation pressure range

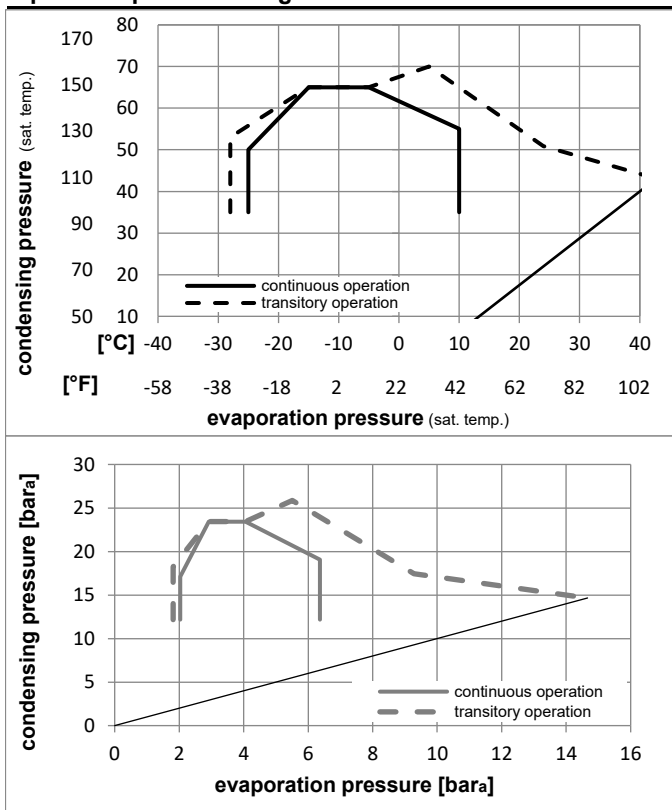

Components

a1	e-PTC starter (220V, 250hm, 4.8mm)	103N0050
e	run capacitor (4μF, 4.8mm)	117-7119
b	plastic cover	103N2010
d	cord relief	103N1010
	bracket for run capacitor	117-0300
	screw M4x8mm	117-0301

Alternative components

b	plastic cover	103N2011
---	---------------	----------

Model

Designation **NLE12.6MN 220-240V/50Hz** Conf. **3** Sales code: **105H6377**

Optimization + standard conditions

220-240V/50Hz 1~, RSCR, fan 3m/s, VDE, CCC, EAC

Evaporating pressure (saturation temperature)		Condensing pressure (saturation temperature)				Cooling capacity						Power consumption			ASHRAE MBP	
pe		pc		RGT	Tliq		COP			EER			P1	I		m
[°C]	[°F]	[°C]	[°F]	[°C]	[°C]	[°F]	[W]	[Btu/h]	[kcal/h]	[W/W]	[Btu/Wh]	[kcal/Wh]	[W]	[A]	[kg/h]	
-6,66	20	54,4	130	35	46,1	115	1070,3	3655	921,1	2,08	7,12	1,79	513,5	2,78	12,21	ASHRAE MBP
-10	14	55	131	89,6	32	131	849,7	2902	731,3	1,75	5,97	1,51	485,8	2,67	10,75	cecomaf MBP
-10	14	45	113	68	20	113	956,9	3268	823,5	2,16	7,39	1,86	442,5	2,49	11,75	EN12900 MBP
-6,66	20	48,9	120	65	18,3	120	1012,9	3459	871,7	2,09	7,14	1,80	484,2	2,65	13,15	ARI540 MBP
-10	14	45	113	89,6	32	113	996,2	3402	857,3	2,25	7,69	1,94	442,5	2,49	11,40	opt
-25	-13	45	113	89,6	32	113	539,2	1842	464,1	1,60	5,47	1,38	336,8	2,10	6,08	opt

Performance tables

220-240V/50Hz 1~, RSCR, fan 3m/s, VDE, CCC, EAC

[°C / °F]	pe	Cooling capacity			COP			EER			P1	I	m
	[°C]	[°F]	[W]	[Btu/h]	[kcal/h]	[W/W]	[Btu/Wh]	[kcal/Wh]	[W]	[A]	[kg/h]		
-25 / -13	-25	-13	539,2	1842	464,1	1,60	5,47	1,38	336,8	2,10	6,08		
cond. pressure	-20	-4	667,3	2279	574,3	1,79	6,13	1,54	372,1	2,22	7,56		
pc= 45/113	-15	5	819,1	2797	704,9	2,01	6,87	1,73	407,5	2,36	9,32		
return gas temp.	-10	14	996,2	3402	857,3	2,25	7,69	1,94	442,5	2,49	11,40		
RGT= 32/90	0	32	1433,1	4894	1233,3	2,81	9,61	2,42	509,3	2,76	16,62		
liquid temp	5	41	1696,2	5793	1459,8	3,14	10,72	2,70	540,2	2,89	19,84		
Tliq= 45/113	10	50	1991,4	6801	1713,8	3,50	11,96	3,01	568,7	3,01	23,53		
-25 / -13	-25	-13	454,1	1551	390,8	1,27	4,34	1,09	357,1	2,17	5,65		
cond. pressure	-20	-4	565,3	1931	486,5	1,42	4,85	1,22	397,9	2,32	7,07		
pc= 55/131	-15	5	696,6	2379	599,5	1,58	5,39	1,36	441,0	2,49	8,76		
return gas temp.	-10	14	849,7	2902	731,3	1,75	5,97	1,51	485,8	2,67	10,75		
RGT= 32/90	0	32	1227,9	4194	1056,8	2,12	7,25	1,83	578,7	3,07	15,77		
liquid temp	5	41	1456,5	4974	1253,4	2,33	7,95	2,00	625,8	3,27	18,89		
Tliq= 55/131	10	50	1713,5	5852	1474,6	2,55	8,70	2,19	672,8	3,49	22,47		