

Model

Designation	SC18GH	220-240V/50Hz 1~ 220-240V/60Hz 1~	Sales code:	104G8861
-------------	---------------	-----------------------------------	-------------	-----------------

Compressor design

Oil type	Polyolester	Refrigerant(s)	R134a, R513A
Oil viscosity	22cST	Displacement	17,69cm ³ / 1,08cu.in
Oil quantity	500cm ³ / 16,9fl.oz	Compressors on pallet	80
Refr. charge - tech. limit	1300g / 45,9oz		
Free gas volume comp.	1460cm ³ / 49,4fl.oz		
Weight	13,8kg / 30,4lbs		
Motor protection	1# internal		
Winding resistance main	3,5Ω (at 25°C)		
Winding resistance aux	13Ω (at 25°C)		
Max. winding temp.	125°C / 257°F		
Max. discharge temp.	130°C / 266°F		



General - Configurations with SC18GH

	Conf. 1	Conf. 2	Conf. 3	Conf. 4
Motorconfiguration	CSCR	CSCR	CSCR	CSCR
Power supply (nominal)	220-240V/50Hz	220-240V/50Hz	208-230V/60Hz	208-230V/60Hz
Number of phases	1	1	1	1
Voltage range	198-254V	198-254V	198-254V	198-254V
Approvals	VDE, UL, CCC, KC	VDE, UL, CCC	VDE, UL, CCC, KC	VDE, UL, CCC
Starting torque	HST	HST	HST	HST
Note	- / -			

Applications with SC18GH

	Conf. 1	Conf. 2	Conf. 3	Conf. 4
Refrigerant	R134a	R513A	R134a	R513A
Application	HBP	HBP	HBP	HBP
System cooling	fan 3m/s	fan 3m/s	fan 3m/s	fan 3m/s
Hot gas defrost	OK	OK	OK	OK
Long interval pull down	OK	OK	OK	OK

Electrical data - Configurations with SC18GH

	Conf. 1	Conf. 2	Conf. 3	Conf. 4
Starting device type	relay	relay	relay	relay
Run capacitor	10μF	10μF	10μF	10μF
Start capacitor	80μF	80μF	80μF	80μF
LRA (locked rotor amps / 4s)	22A	22A	21,2A	21,2A
RLA (rated load amps / 1s)	3,9A	3,9A	3,5A	3,5A
Cut in current	22A	22A	21,2A	21,2A
IP class	21	21	21	21

Model

Designation	SC18GH	220-240V/50Hz 1~ 220-240V/60Hz 1~	Sales code:	104G8861
-------------	---------------	-----------------------------------	-------------	-----------------

Compressor dimensions

Housing	A Height	219mm / 8,62in
	B Height	213mm / 8,39in
	C Length shell	218mm / 8,58in
	D Length w. cover	255mm / 10,04in
	E Width	151mm / 5,94in

Connectors		Suction	Discharge	Process
		X	Y	Z
Diameter	[mm]	øi 10,11-10,29	øi 8,11-8,29	øi 6,11-6,29
(i:inside, o:outside)	[in]	øi 0,4-0,41	øi 0,32-0,33	øi 0,24-0,25
Material		copper	copper	copper
Horizontal angle	±2°	37°	37°	143°
Vertical angle	±2°	30°	0°	150°
Position l/h/w	[mm]	107/193/55	115/110/63	-107/193/55
	[in]	4,2/7,6/2,2	4,5/4,3/2,5	-4,2/7,6/2,2
Straight tube l.	[mm]	12	12	12
	[in]	0,5	0,5	0,5

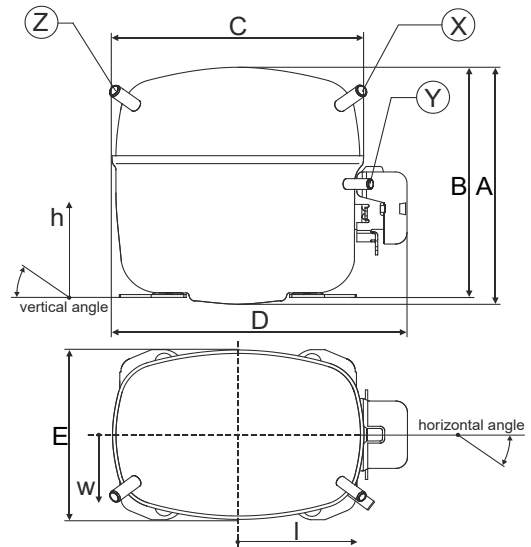

Compressor fixation

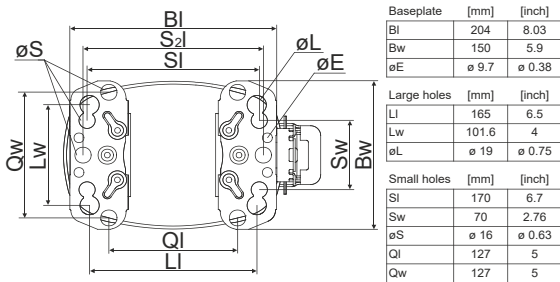

Bolt joint

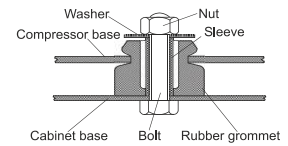

Snap-on

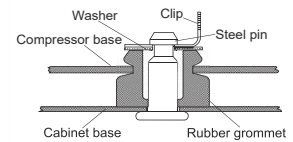

Mounting accessories

	one comp.	multi pack
Bolt joint M6 ø16mm	118-1917	118-1918
Bolt joint ø1/4" ø16mm	118-1946	
Bolt joint ø1/4" ø19mm	118-1949	
Snap-on ø7,3 ø16mm	118-1947	118-1919

Model

Designation **SC18GH 220-240V/50Hz** Conf. 1 Sales code: **104G8861**

Configuration

Motorconfiguration **CSCR**
 Power supply (nominal) **220-240V/50Hz 1~**
 Refrigerant **R134a**
 Application **HBP**
 Voltage range **198-254V**
 Starting torque **HST**
 Approvals **VDE**
UL
CCC
KC

Electrical accessories / wiring diagram

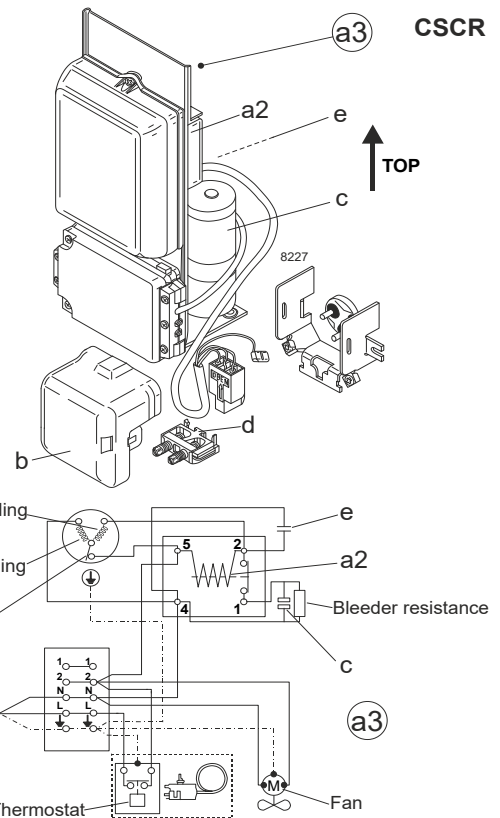

Ambient temperatures / system cooling

Ambient temperature min.: **10°C / 50°F**
 Ambient temperature max.: **43°C / 110°F**

System cooling (n/a: outside limits)			
T ambient	LBP	MBP	HBP
32°C / 90°F	n/a	n/a	fan 3m/s
38°C / 100°F	n/a	n/a	fan 3m/s
43°C / 110°F	n/a	n/a	fan 3m/s

Operation pressure range

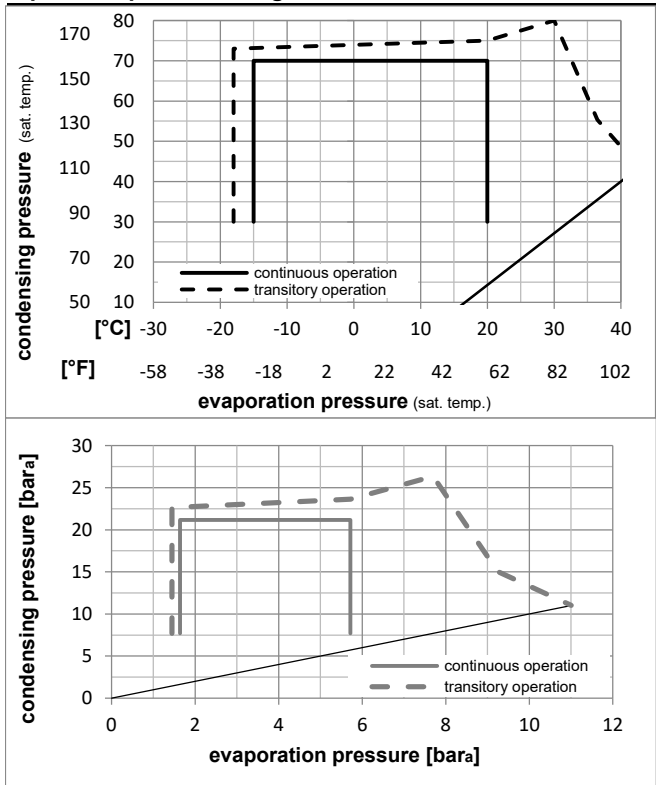

Components

- a3 SC starter kit (550mm) 117-7039
- b plastic cover 103N2008
- d cord relief 103N1004

Alternative components

- a3 SC starter kit (1000mm) 117-7043

Model

Designation **SC18GH 220-240V/50Hz** Conf. 1 Sales code: **104G8861**

Optimization + standard conditions

220V/50Hz, CSCR, fan 3m/s, VDE, UL, CCC, KC

Evaporating pressure (saturation temperature)					Condensing pressure (saturation temperature)						Power consumption				ASHRAE HBP
					Return gas temp.						Current consumption				
					Liquid temp.						Ref. mass flow				
					Cooling capacity						COP EER				
	pe	pc	RGT	Tliq	[W]	[Btu/h]	[kcal/h]	[W/W]	[Btu/Wh]	[kcal/Wh]	P1 [W]	I [A]	m [kg/h]		
[°C]	7,22	54,4	35	46,1	1600,1	5465	1377,1	2,57	8,78	2,21	622,6	3,33	35,50	ASHRAE HBP	
[°F]	45	130	95	115											
[°C]	5	55	32	55	1310,2	4475	1127,6	2,17	7,40	1,87	604,6	3,26	32,29	cecomaf HBP	
[°F]	41	131	89,6	131											
[°C]	5	50	20	50	1362,6	4654	1172,7	2,35	8,02	2,02	579,9	3,15	34,34	EN12900 HBP	
[°F]	41	122	68	122											
[°C]	-6,66	54,4	35	46,1	842,7	2878	725,2	1,74	5,95	1,50	483,7	2,79	18,39	ASHRAE MBP	
[°F]	20	130	95	115											
[°C]	-10	55	32	55	639,5	2184	550,3	1,42	4,84	1,22	451,6	2,66	15,46	cecomaf MBP	
[°F]	14	131	89,6	131											
[°C]	-10	45	20	45	747,8	2554	643,5	1,73	5,90	1,49	432,8	2,59	17,50	EN12900 MBP	
[°F]	14	113	68	113											

Performance tables

220V/50Hz, CSCR, fan 3m/s, VDE, UL, CCC, KC

	pe	Cooling capacity			COP	EER	P1	I	m		
	[°C]	[°F]	[W]	[Btu/h]	[kcal/h]	[W/W]	[Btu/Wh]	[kcal/Wh]	[W]	[A]	[kg/h]
[°C / °F]	-15	5	596,9	2039	513,7	1,54	5,26	1,32	387,9	2,42	13,01
cond. pressure	-10	14	775,8	2649	667,6	1,79	6,12	1,54	432,8	2,59	16,98
pc= 45/113	-5	23	989,5	3379	851,6	2,07	7,07	1,78	477,7	2,75	21,76
return gas temp.	0	32	1242,7	4244	1069,5	2,39	8,16	2,06	520,4	2,90	27,48
RGT= 32/90	5	41	1539,8	5259	1325,2	2,76	9,42	2,37	558,5	3,04	34,28
liquid temp	15	59	2283,9	7800	1965,6	3,73	12,74	3,21	612,3	3,31	51,73
Tliq= 45/113	20	68	2739,9	9357	2358,0	4,40	15,01	3,78	623,3	3,44	62,75
[°C / °F]	-15	5	485,4	1658	417,8	1,20	4,11	1,03	403,8	2,44	11,69
cond. pressure	-10	14	639,5	2184	550,3	1,42	4,84	1,22	451,6	2,66	15,46
pc= 55/131	-5	23	825,2	2818	710,2	1,64	5,61	1,41	502,5	2,86	20,06
return gas temp	0	32	1047,3	3577	901,4	1,89	6,45	1,63	554,3	3,06	25,62
RGT= 32/90	5	41	1310,2	4475	1127,6	2,17	7,40	1,87	604,6	3,26	32,29
liquid temp	15	59	1976,5	6750	1701,0	2,86	9,76	2,46	691,9	3,63	49,64
Tliq= 55/131	20	68	2388,8	8158	2055,8	3,30	11,26	2,84	724,3	3,80	60,75

Model

Designation	SC18GH	220-240V/50Hz	Conf. 2	Sales code:	104G8861
-------------	---------------	----------------------	----------------	-------------	-----------------

Configuration

Motorconfiguration	CSCR
Power supply (nominal)	220-240V/50Hz 1~
Refrigerant	R513A
Application	HBP
Voltage range	198-254V
Starting torque	HST
Approvals	VDE UL CCC

Electrical accessories / wiring diagram

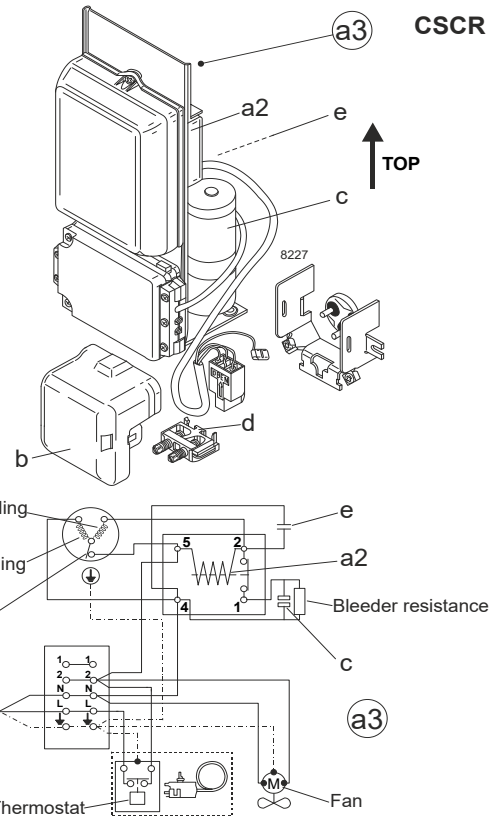

Ambient temperatures / system cooling

Ambient temperature min.:	10°C / 50°F
Ambient temperature max.:	43°C / 110°F

System cooling (n/a: outside limits)			
T ambient	LBP	MBP	HBP
32°C / 90°F	n/a	n/a	fan 3m/s
38°C / 100°F	n/a	n/a	fan 3m/s
43°C / 110°F	n/a	n/a	fan 3m/s

Operation pressure range

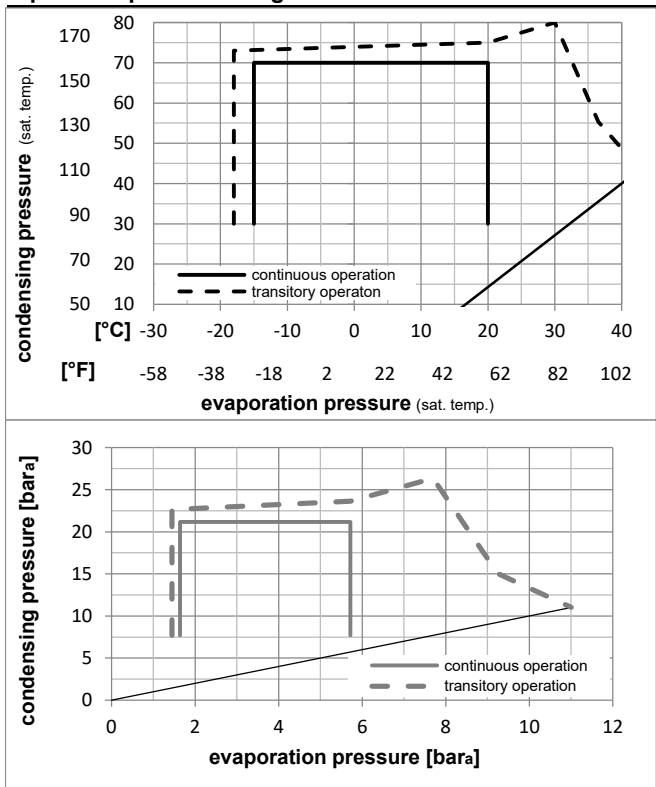

Components

a3	SC starter kit (550mm)	117-7039
b	plastic cover	103N2008
d	cord relief	103N1004

Alternative components

a3	SC starter kit (1000mm)	117-7043
----	-------------------------	----------

Model

Designation **SC18GH 220-240V/50Hz** Conf. 2 Sales code: **104G8861**

Optimization + standard conditions

220V/50Hz, CSCR, fan 3m/s, VDE, UL, CCC

Evaporating pressure (saturation temperature)														
Condensing pressure (saturation temperature)														
Return gas temp.														
Liquid temp.														
Cooling capacity														
COP														
EER														
Power consumption														
Current consumption														
Ref. mass flow														
	pe	pc	RGT	Tliq	[W]	[Btu/h]	[kcal/h]	[W/W]	[Btu/Wh]	[kcal/Wh]	P1	I	m	
[°C]	[°C]	[°C]	[°C]	[°C]							[W]	[A]	[kg/h]	
[°F]	7,22	54,4	35	46,1	1645,0	5618	1415,7	2,53	8,63	2,17	651,3	3,44	40,86	ASHRAE HBP
	45	130	95	115										
[°C]	5	55	32	55	1327,3	4533	1142,3	2,09	7,15	1,80	633,9	3,37	37,30	cecomaf HBP
[°F]	41	131	89,6	131										
[°C]	5	50	20	50	1382,8	4722	1190,0	2,28	7,77	1,96	607,7	3,26	39,65	EN12900 HBP
[°F]	41	122	68	122										
[°C]	-6,66	54,4	35	46,1	885,4	3024	762,0	1,72	5,88	1,48	514,5	2,88	21,69	ASHRAE MBP
[°F]	20	130	95	115										
[°C]	-10	55	32	55	664,3	2269	571,7	1,38	4,70	1,18	482,8	2,75	18,37	cecomaf MBP
[°F]	14	131	89,6	131										
[°C]	-10	45	20	45	782,0	2671	673,0	1,69	5,79	1,46	461,4	2,66	20,73	EN12900 MBP
[°F]	14	113	68	113										

Performance tables

220V/50Hz, CSCR, fan 3m/s, VDE, UL, CCC

	pe	Cooling capacity			COP	EER	P1	I	m			
		[°C]	[°F]	[W]						[Btu/h]	[kcal/h]	[W/W]
[°C / °F]	-15	5		635,5	2170	546,9	1,53	5,21	1,31	416,5	2,47	15,57
cond. pressure	-10	14		817,8	2793	703,8	1,77	6,05	1,53	461,4	2,66	20,11
pc= 45/113	-5	23		1034,2	3532	890,0	2,04	6,98	1,76	506,0	2,84	25,53
return gas temp.	0	32		1289,0	4402	1109,3	2,35	8,03	2,02	548,0	3,01	31,97
RGT= 32/90	5	41		1586,4	5418	1365,3	2,71	9,26	2,33	585,2	3,17	39,57
liquid temp	15	59		2326,1	7944	2001,9	3,66	12,49	3,15	636,0	3,37	58,85
Tliq= 45/113	20	68		2776,9	9484	2389,9	4,30	14,70	3,70	645,2	3,41	70,90
[°C / °F]	-15	5		509,9	1741	438,8	1,17	4,00	1,01	435,3	2,55	14,05
cond. pressure	-10	14		664,3	2269	571,7	1,38	4,70	1,18	482,8	2,75	18,37
pc= 55/131	-5	23		849,2	2900	730,8	1,59	5,44	1,37	533,3	2,95	23,59
return gas temp	0	32		1068,7	3650	919,8	1,83	6,25	1,57	584,4	3,16	29,85
RGT= 32/90	5	41		1327,3	4533	1142,3	2,09	7,15	1,80	633,9	3,37	37,30
liquid temp	15	59		1978,3	6756	1702,5	2,75	9,39	2,37	719,1	3,72	56,50
Tliq= 55/131	20	68		2379,3	8126	2047,6	3,17	10,83	2,73	750,3	3,84	68,65

Model

Designation	SC18GH	208-230V/60Hz	Conf. 3	Sales code:	104G8861
-------------	---------------	----------------------	----------------	-------------	-----------------

Configuration

Motorconfiguration	CSCR
Power supply (nominal)	208-230V/60Hz 1~
Refrigerant	R134a
Application	HBP
Voltage range	198-254V
Starting torque	HST
Approvals	VDE
	UL
	CCC
	KC

Electrical accessories / wiring diagram

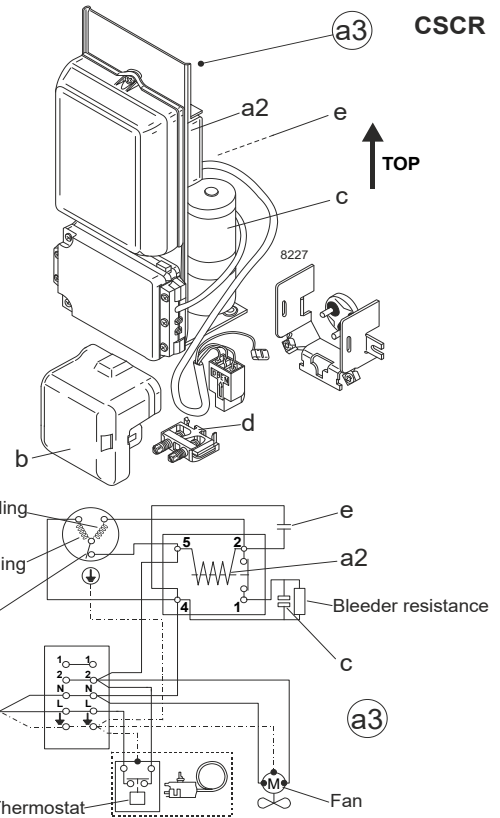

Ambient temperatures / system cooling

Ambient temperature min.:	10°C / 50°F
Ambient temperature max.:	43°C / 110°F

System cooling (n/a: outside limits)			
T ambient	LBP	MBP	HBP
32°C / 90°F	n/a	n/a	fan 3m/s
38°C / 100°F	n/a	n/a	fan 3m/s
43°C / 110°F	n/a	n/a	fan 3m/s

Operation pressure range

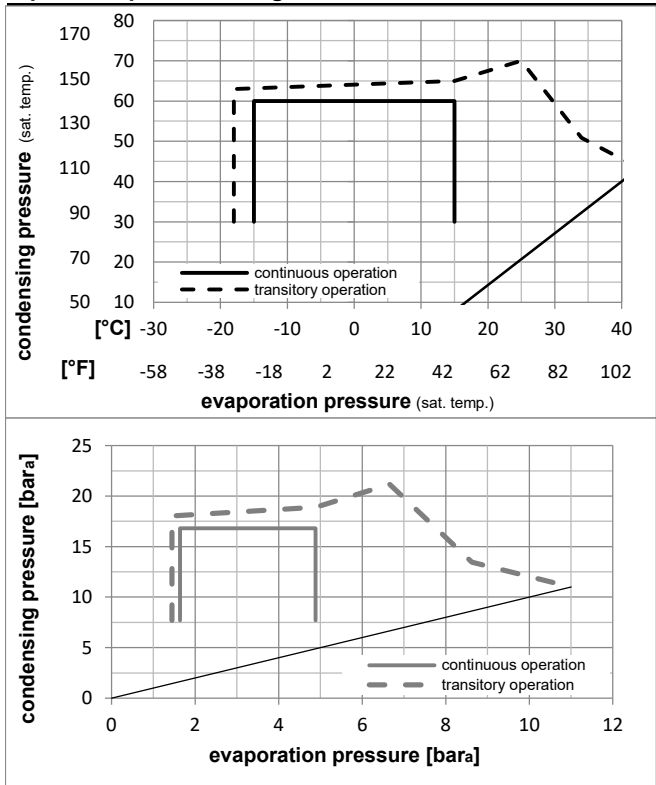

Components

a3	SC starter kit (550mm)	117-7039
b	plastic cover	103N2008
d	cord relief	103N1004

Alternative components

a3	SC starter kit (1000mm)	117-7043
----	-------------------------	----------

Model

Designation **SC18GH 208-230V/60Hz** Conf. **3** Sales code: **104G8861**

Optimization + standard conditions

220V/60Hz, CSCR, fan 3m/s, VDE, UL, CCC, KC

Evaporating pressure (saturation temperature)					Condensing pressure (saturation temperature)						Power consumption				ASHRAE HBP
Return gas temp.					Liquid temp.						Current consumption			Ref. mass flow ṁ	
Cooling capacity					COP		EER		P1	I	ṁ				
pe	pc	RGT	Tliq	[W]	[Btu/h]	[kcal/h]	[W/W]	[Btu/Wh]	[kcal/Wh]	[W]	[A]	[kg/h]			
[°C]	7,22	54,4	35	46,1	1839,2	6281	1582,9	2,51	8,57	2,16	733,1	3,47	40,80	ASHRAE HBP	
[°F]	45	130	95	115											
[°C]	5	55	32	55	1506,3	5144	1296,4	2,13	7,27	1,83	708,0	3,35	37,12	cecomaf HBP	
[°F]	41	131	89,6	131											
[°C]	5	50	20	50	1570,6	5364	1351,7	2,29	7,83	1,97	684,6	3,26	39,58	EN12900 HBP	
[°F]	41	122	68	122											
[°C]	-6,66	54,4	35	46,1	977,1	3337	840,9	1,77	6,03	1,52	553,6	2,65	21,32	ASHRAE MBP	
[°F]	20	130	95	115											
[°C]	-10	55	32	55	744,9	2544	641,0	1,46	4,97	1,25	511,5	2,45	18,01	cecomaf MBP	
[°F]	14	131	89,6	131											
[°C]	-10	45	20	45	872,3	2979	750,7	1,76	6,00	1,51	496,2	2,42	20,42	EN12900 MBP	
[°F]	14	113	68	113											

Performance tables

220V/60Hz, CSCR, fan 3m/s, VDE, UL, CCC, KC

	pe	Cooling capacity			COP	EER	P1	I	m		
	[°C]	[°F]	[W]	[Btu/h]	[kcal/h]	[W/W]	[Btu/Wh]	[kcal/Wh]	[W]	[A]	[kg/h]
[°C / °F]	-15	5	702,5	2399	604,6	1,60	5,46	1,38	439,1	2,18	15,31
cond. pressure	-10	14	904,9	3091	778,8	1,82	6,23	1,57	496,2	2,42	19,80
pc= 45/113	-5	23	1148,0	3920	987,9	2,07	7,08	1,78	553,5	2,66	25,24
return gas temp.	0	32	1436,7	4906	1236,4	2,36	8,06	2,03	609,1	2,90	31,77
RGT= 32/90	5	41	1776,1	6066	1528,5	2,69	9,18	2,31	660,6	3,13	39,54
liquid temp	10	50	2171,3	7416	1868,7	3,08	10,50	2,65	705,9	3,37	48,72
Tliq= 45/113	15	59	2627,4	8973	2261,2	3,54	12,08	3,04	742,9	3,60	59,51
[°C / °F]	-15	5	572,5	1955	492,7	1,27	4,35	1,10	449,5	2,14	13,78
cond. pressure	-10	14	744,9	2544	641,0	1,46	4,97	1,25	511,5	2,45	18,01
pc= 55/131	-5	23	954,6	3260	821,5	1,66	5,65	1,42	576,7	2,75	23,20
return gas temp	0	32	1206,7	4121	1038,5	1,88	6,41	1,62	642,9	3,05	29,52
RGT= 32/90	5	41	1506,3	5144	1296,4	2,13	7,27	1,83	708,0	3,35	37,12
liquid temp	10	50	1858,5	6347	1599,4	2,41	8,24	2,08	769,8	3,65	46,20
Tliq= 55/131	15	59	2268,2	7746	1952,0	2,75	9,38	2,36	826,2	3,94	56,97

Model

Designation	SC18GH	208-230V/60Hz	Conf. 4	Sales code:	104G8861
-------------	---------------	----------------------	----------------	-------------	-----------------

Configuration

Motorconfiguration	CSCR
Power supply (nominal)	208-230V/60Hz 1~
Refrigerant	R513A
Application	HBP
Voltage range	198-254V
Starting torque	HST
Approvals	VDE UL CCC

Electrical accessories / wiring diagram

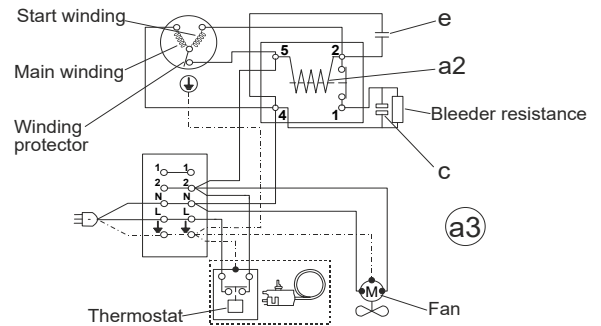
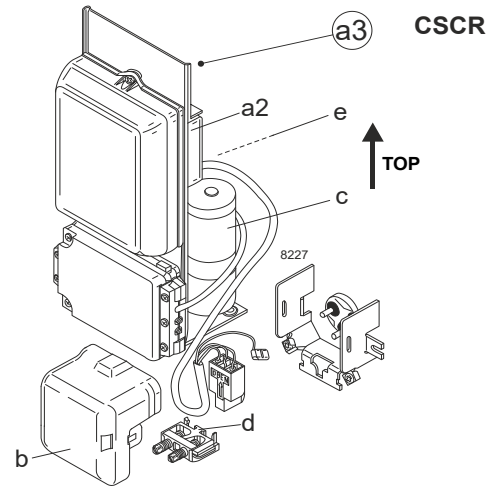

Ambient temperatures / system cooling

Ambient temperature min.:	10°C / 50°F
Ambient temperature max.:	43°C / 110°F

System cooling (n/a: outside limits)			
T ambient	LBP	MBP	HBP
32°C / 90°F	n/a	n/a	fan 3m/s
38°C / 100°F	n/a	n/a	fan 3m/s
43°C / 110°F	n/a	n/a	fan 3m/s

Operation pressure range

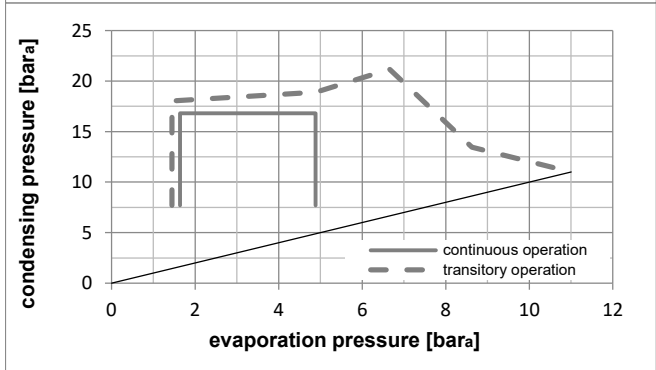
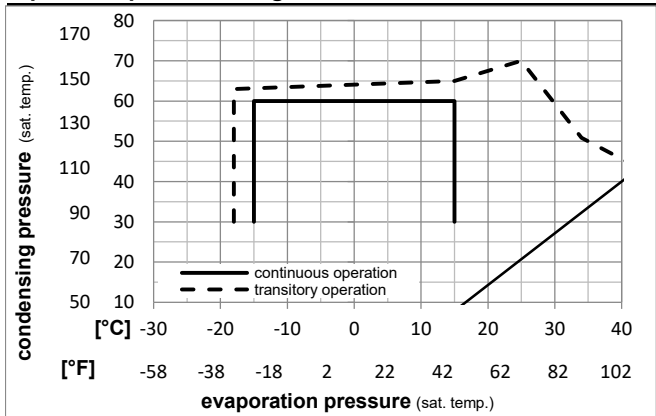

Components

a3	SC starter kit (550mm)	117-7039
b	plastic cover	103N2008
d	cord relief	103N1004

Alternative components

a3	SC starter kit (1000mm)	117-7043
----	-------------------------	----------

Model

Designation **SC18GH 208-230V/60Hz** Conf. 4 Sales code: **104G8861**

Optimization + standard conditions

220V/60Hz, CSCR, fan 3m/s, VDE, UL, CCC

Evaporating pressure (saturation temperature)														
Condensing pressure (saturation temperature)														
Return gas temp.														
Liquid temp.														
Cooling capacity														
COP														
EER														
Power consumption														
Current consumption														
Ref. mass flow														
	pe	pc	RGT	Tliq	[W]	[Btu/h]	[kcal/h]	[W/W]	[Btu/Wh]	[kcal/Wh]	P1	I	m	
[°C]	[°C]	[°C]	[°C]	[°C]							[W]	[A]	[kg/h]	
[°F]	7,22	54,4	35	46,1	1892,4	6463	1628,6	2,47	8,44	2,13	765,7	3,65	47,01	ASHRAE HBP
	45	130	95	115										
[°C]	5	55	32	55	1527,2	5216	1314,3	2,06	7,04	1,77	741,0	3,53	42,92	cecomaf HBP
[°F]	41	131	89,6	131										
[°C]	5	50	20	50	1595,1	5448	1372,8	2,23	7,60	1,92	716,3	3,41	45,74	EN12900 HBP
[°F]	41	122	68	122										
[°C]	-6,66	54,4	35	46,1	1027,5	3509	884,3	1,75	5,98	1,51	586,5	2,79	25,17	ASHRAE MBP
[°F]	20	130	95	115										
[°C]	-10	55	32	55	774,5	2645	666,6	1,42	4,86	1,22	544,3	2,59	21,42	cecomaf MBP
[°F]	14	131	89,6	131										
[°C]	-10	45	20	45	913,0	3118	785,8	1,73	5,92	1,49	526,6	2,50	24,20	EN12900 MBP
[°F]	14	113	68	113										

Performance tables

220V/60Hz, CSCR, fan 3m/s, VDE, UL, CCC

	pe	Cooling capacity			COP	EER	P1	I	m		
	[°C]	[°F]	[W]	[Btu/h]	[kcal/h]	[W/W]	[Btu/Wh]	[kcal/Wh]	[W]	[A]	[kg/h]
[°C / °F]	-15	5	748,7	2557	644,4	1,60	5,45	1,37	469,2	2,23	18,35
cond. pressure	-10	14	954,7	3261	821,7	1,81	6,19	1,56	526,6	2,50	23,47
pc= 45/113	-5	23	1200,7	4100	1033,3	2,06	7,02	1,77	584,2	2,78	29,64
return gas temp.	0	32	1491,2	5093	1283,3	2,33	7,96	2,01	639,7	3,05	36,99
RGT= 32/90	5	41	1831,1	6253	1575,8	2,65	9,05	2,28	690,9	3,29	45,67
liquid temp	10	50	2225,0	7599	1914,8	3,03	10,33	2,60	735,4	3,50	55,86
Tliq= 45/113	15	59	2677,6	9144	2304,4	3,47	11,86	2,99	771,1	3,68	67,75
[°C / °F]	-15	5	602,0	2056	518,1	1,25	4,27	1,08	482,0	2,29	16,58
cond. pressure	-10	14	774,5	2645	666,6	1,42	4,86	1,22	544,3	2,59	21,42
pc= 55/131	-5	23	983,1	3357	846,0	1,61	5,51	1,39	609,8	2,90	27,31
return gas temp	0	32	1232,4	4209	1060,6	1,82	6,23	1,57	676,1	3,22	34,42
RGT= 32/90	5	41	1527,2	5216	1314,3	2,06	7,04	1,77	741,0	3,53	42,92
liquid temp	10	50	1872,2	6394	1611,3	2,33	7,97	2,01	802,3	3,83	53,00
Tliq= 55/131	15	59	2272,2	7760	1955,5	2,65	9,05	2,28	857,7	4,09	64,89