

Model

Designation	SC21CNX.2	220-240V/50Hz 1~	Sales code:	104H8166
-------------	------------------	------------------	-------------	-----------------

Compressor design

Oil type	Polyolester	Refrigerant(s)	R290
Oil viscosity	32cST	Displacement	20,95cm ³ / 1,28cu.in
Oil quantity	550cm ³ / 18,6fl.oz	Compressors on pallet	80
Refr. charge - tech. limit	150g / 5,3oz		
Free gas volume comp.	1410cm ³ / 47,7fl.oz		
Weight	14,1kg / 31,1lbs		
Motor protection	1# internal		
Winding resistance main	3,3Ω (at 25°C)		
Winding resistance aux	16,5Ω (at 25°C)		
Max. winding temp.	125°C / 257°F		
Max. discharge temp.	130°C / 266°F		



General - Configurations with SC21CNX.2

	Conf. 1
Motorconfiguration	CSIR
Power supply (nominal)	220-240V/50Hz
Number of phases	1
Voltage range	198-254V
Approvals	VDE, CCC
Starting torque	HST
Note	- / -

Applications with SC21CNX.2

	Conf. 1
Refrigerant	R290
Application	LBP
System cooling	fan 3m/s
Hot gas defrost	OK
Long interval pull down	OK

Electrical data - Configurations with SC21CNX.2

	Conf. 1
Starting device type	relay
Run capacitor	- / -
Start capacitor	125μF
LRA (locked rotor amps / 4s)	23,5A
RLA (rated load amps / 1s)	4,5A
Cut in current	23,5A

Model

Designation **SC21CNX.2** 220-240V/50Hz 1~

Sales code: **104H8166**

Compressor dimensions

Housing	A Height	219mm / 8,62in
	B Height	213mm / 8,39in
	C Length shell	218mm / 8,58in
	D Length w. cover	255mm / 10,04in
	E Width	151mm / 5,94in

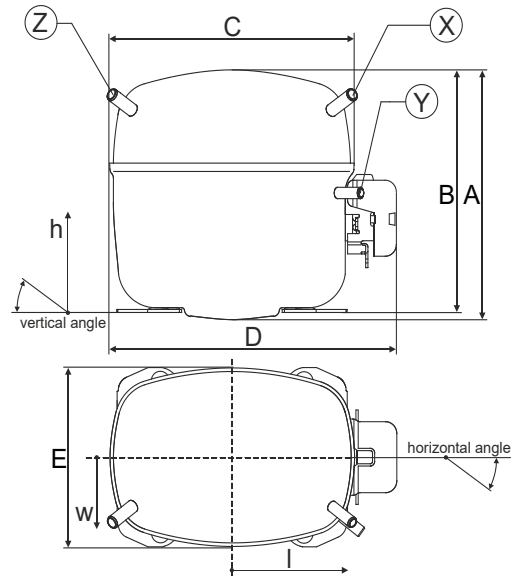

Connectors		Suction	Discharge	Process
		X	Y	Z
Diameter	[mm]	øi 10,11-10,29	øi 6,11-6,29	øi 6,11-6,29
	(i:inside, o:outside) [in]	øi 0,4-0,41	øi 0,24-0,25	øi 0,24-0,25
Material		copper	copper	copper
Horizontal angle	±2°	37°	37°	143°
Vertical angle	±2°	30°	0°	150°
Position l/h/w	[mm]	107/193/55	115/110/63	-107/193/55
	[in]	4,2/7,6/2,2	4,5/4,3/2,5	-4,2/7,6/2,2
Straight tube l.	[mm]	12	12	12
	[in]	0,5	0,5	0,5

Compressor fixation

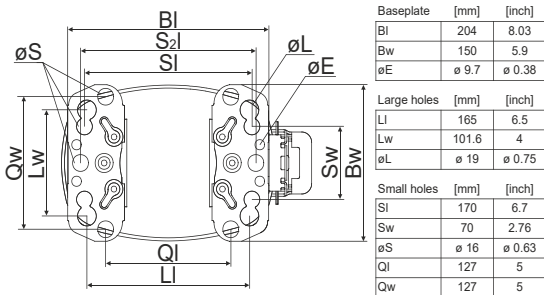

Bolt joint

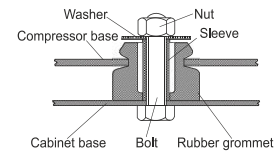

Snap-on

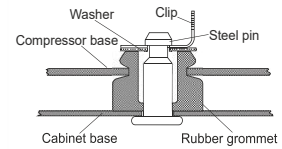

Mounting accessories	one comp.	multi pack
Bolt joint M6 ø16mm	118-1917	118-1918
Bolt joint ø1/4" ø16mm	118-1946	
Bolt joint ø1/4" ø19mm	118-1949	
Snap-on ø7,3 ø16mm	118-1947	118-1919

Model

Designation	SC21CNX.2	220-240V/50Hz	Conf. 1	Sales code:	104H8166
-------------	------------------	----------------------	----------------	-------------	-----------------

Configuration

Motorconfiguration	CSIR
Power supply (nominal)	220-240V/50Hz 1~
Refrigerant	R290
Application	LBP
Voltage range	198-254V
Starting torque	HST
Approvals	VDE CCC

Electrical accessories / wiring diagram

CSIR

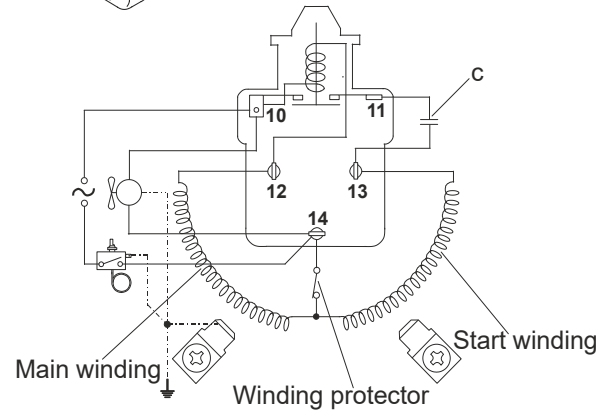
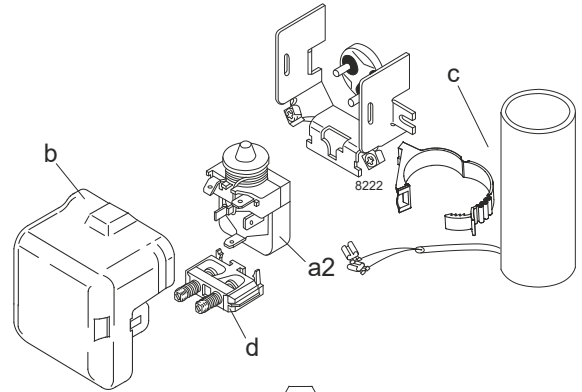

Ambient temperatures / system cooling

Ambient temperature min.:	10°C / 50°F
Ambient temperature max.:	43°C / 110°F

System cooling (n/a: outside limits)			
T ambient	LBP	MBP	HBP
32°C / 90°F	fan 3m/s	n/a	n/a
38°C / 100°F	fan 3m/s	n/a	n/a
43°C / 110°F	fan 3m/s	n/a	n/a

Operation pressure range

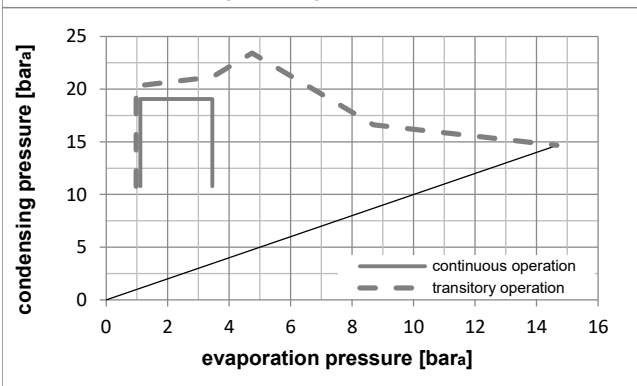
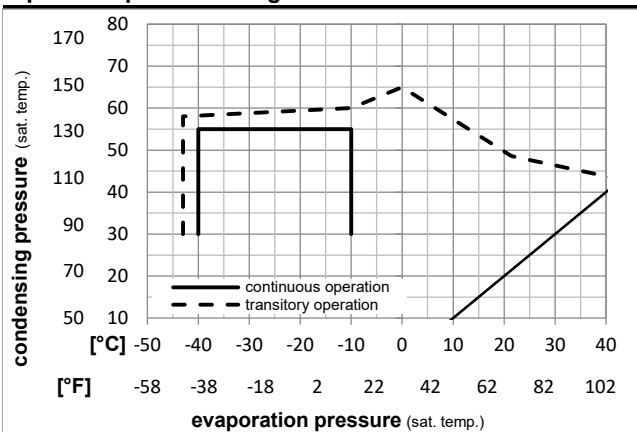

Components

a2	relay	117U7013
c	start capacitor (125µF)	117U5012
d	cord relief	103N1004
b	plastic cover	103N2009

Alternative components

c	start capacitor (125µF)	117U5069
---	-------------------------	----------

Model

Designation	SC21CNX.2	220-240V/50Hz	Conf. 1	Sales code:	104H8166
-------------	------------------	----------------------	----------------	-------------	-----------------

Optimization + standard conditions

R290, 220V/50Hz, CSIR, fan 3m/s, VDE, CCC

		Evaporating pressure (saturation temperature)				Condensing pressure (saturation temperature)						Power consumption					
						Return gas temp.						Current consumption					
						Liquid temp.						Ref. mass flow					
						Cooling capacity						COP	EER	P1	I	m	
		pe	pc	RGT	Tliq	[W]	[Btu/h]	[kcal/h]	[W/W]	[Btu/Wh]	[kcal/Wh]	[W]	[A]	[kg/h]			
[°C]	-23,3	54,4	32,2	32,2	960,5	3280	826,6	1,45	4,96	1,25	661,4	4,19	9,73	ASHRAE LBP			
[°F]	-10	130	90	90													
[°C]	-25	55	32	55	715,7	2444	616,0	1,12	3,82	0,96	639,2	4,10	8,91	cecomaf LBP			
[°F]	-13	131	89,6	131													
[°C]	-35	40	20	40	540,5	1846	465,2	1,09	3,72	0,94	495,6	3,59	6,18	EN12900 LBP			
[°F]	-31	104	68	104													
[°C]	-23,3	48,9	4,44	48,9	767,9	2622	660,9	1,18	4,04	1,02	648,4	4,11	10,63	ARI540 LBP			
[°F]	-10	120	40	120													
[°C]	-23,3	40,6	32,2	32,2	1008,0	3443	867,5	1,57	5,36	1,35	642,8	4,01	10,21	AHAM LBP			
[°F]	-10	105	90	90													
[°C]	-35	45	32	45	491,9	1680	423,4	1,00	3,42	0,86	491,2	3,58	5,51	opt			
[°F]	-31	113	89,6	113													

Performance tables

R290, 220V/50Hz, CSIR, fan 3m/s, VDE, CCC

	pe	Cooling capacity			COP	EER	P1	I	m		
	[°C]	[°F]	[W]	[Btu/h]	[kcal/h]	[W/W]	[Btu/Wh]	[kcal/Wh]	[W]	[A]	[kg/h]
[°C / °F]	-40	-40	338,6	1156	291,4	0,78	2,68	0,68	431,4	3,43	3,79
cond. pressure	-35	-31	491,9	1680	423,4	1,00	3,42	0,86	491,2	3,58	5,51
pc= 45/113	-30	-22	653,8	2233	562,6	1,18	4,02	1,01	554,9	3,76	7,35
return gas temp.	-25	-13	828,3	2829	712,9	1,33	4,54	1,14	622,9	3,98	9,34
RGT= 32/90	-20	-4	1019,8	3483	877,7	1,47	5,01	1,26	695,3	4,23	11,55
liquid temp	-15	5	1232,6	4209	1060,8	1,60	5,45	1,37	772,5	4,52	14,02
Tliq= 45/113	-10	14	1470,7	5023	1265,7	1,72	5,88	1,48	854,6	4,84	16,83
[°C / °F]	-40	-40	219,1	748	188,6	0,47	1,62	0,41	462,4	3,39	2,70
cond. pressure	-35	-31	372,3	1271	320,4	0,73	2,48	0,63	512,3	3,59	4,60
pc= 55/131	-30	-22	536,4	1832	461,7	0,94	3,21	0,81	571,2	3,83	6,65
return gas temp	-25	-13	715,7	2444	616,0	1,12	3,82	0,96	639,2	4,10	8,91
RGT= 32/90	-20	-4	914,4	3123	786,9	1,28	4,36	1,10	716,6	4,41	11,44
liquid temp	-15	5	1136,7	3882	978,2	1,41	4,83	1,22	803,7	4,75	14,29
Tliq= 55/131	-10	14	1386,8	4736	1193,5	1,54	5,26	1,33	900,6	5,13	17,54