

Kompressor
Spannungscode : FZ

CAJ4519Z-FZ

Gewerbliche Kühlung (Normalk.) (HP)

220 - 240V 1~ 50 Hz

R452A / R404A / R448A / R449A

AJ4519Z-FZ3C

Bedingungen	Frequenz	Nennkälteleistung		Schalleistung ISO3745 / ISO 3743-1
		Watts	BTU/h	
EN12900_MHP / R452A	50 Hz	2625	8950	68 dBA
EN12900_MHP / R404A	50 Hz	2699	9205	68 dBA
EN12900_MHP / R448A	50 Hz	2492	8498	68 dBA
EN12900_MHP / R449A	50 Hz	2492	8498	68 dBA

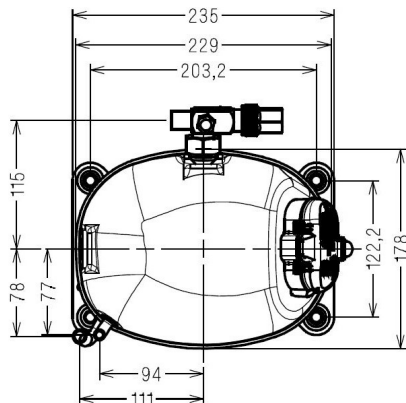

* EN12900_MHP : T°Verf. 45.0°C / T°Verdampf.. -10.0°C / T°Sauggastemp.. 20.0°C
T°Unter Kühlung. 0.0K

Zulassungen :



Hubvolumen (cm³)	34,5
Nettogewicht (kg)	22,3
Ölmenge (cm³)	475,0
Ölsorte	P.O.E
Expansion	Kapillare/Expansionsventil
Kühlung	Belüftet
Hauptphase (Ohm)	1,3
Hilfsphase (Ohm)	6,1
Strom	
Nennstrom (A)	9,9
Maximalstrom (A)	15,2
Anlaufstrom (A)	45
Typ Schaltanlage	CSR
Schutz	GA3SHU00
Verzögerung	7.5s - 14s / 34 A
Öffnungs-Temp.	140° C
Schließ-Temp.	61° C
Anlaufkondensator	100 µF / 250 V
Betriebskondensator	35 µF / 400 V
Potenzialrelais	RVA4G**
Einschaltung	180/195V
Ausschaltung	40/105V
Optional	3ARR3*6AS*
Außendurchmesser	
Ø Saugleitung	15,9 (5/8")
Ø Druckleitung	9,5 (3/8")
Ø Prozessleitung	6,35 (1/4")

NB: Tecumseh behält sich das Recht vor, die in diesem Dokument enthaltenen Informationen ohne vorherige Ankündigung zu verändern





Tecumseh

CAJ4519Z-FZ	Tension FZ : 220 - 240V 1~ 50 Hz
--------------------	---

Les performances sont données dans les **conditions EN12900_MHP** :
 Condition Dew
 The performance data are in **EN12900_MHP conditions** :
 Dew Condition

Gaz aspirés : 20.0 °C
 Sous refroidissement : 0.0 K
 Return gas : 20.0 °C
 Subcooling : 0.0 K

50 Hz R452A											
 N°2288											
4 T condensation	5 T évaporation	(°C)	-25	-20	-15	-10	-5	0	5	10	15
30	1 P frigorifique	(Watt)	1636	2158	2765	3470	4287	5229	6311	7546	8948
	2 P absorbée	(W)	1053	1156	1256	1357	1458	1560	1666	1777	1893
	3 I absorbée	(A)	4.95	5.38	5.80	6.22	6.64	7.07	7.49	7.92	8.35
40	1 P frigorifique	(Watt)		1749	2295	2916	3627	4442	5373	6436	7643
	2 P absorbée	(W)		1218	1345	1468	1589	1710	1831	1955	2082
	3 I absorbée	(A)		5.50	6.07	6.64	7.22	7.79	8.37	8.95	9.54
50	1 P frigorifique	(Watt)			1798	2326	2922	3599	4370	5251	6253
	2 P absorbée	(W)			1403	1561	1715	1866	2015	2164	2313
	3 I absorbée	(A)			6.27	7.00	7.73	8.46	9.19	9.93	10.7
60	1 P frigorifique	(Watt)				1720	2191	2721	3323	4011	4799
	2 P absorbée	(W)				1615	1814	2007	2196	2382	2567
	3 I absorbée	(A)				7.27	8.16	9.05	9.94	10.8	11.7

50 Hz R404A											
 N°224ST-FZ											
4 T condensation	5 T évaporation	(°C)	-25	-20	-15	-10	-5	0	5	10	15
30	1 P frigorifique	(Watt)	1745	2276	2889	3596	4412	5349	6419	7637	9015
	2 P absorbée	(W)	1116	1219	1321	1422	1522	1624	1728	1835	1947
	3 I absorbée	(A)	5.25	5.67	6.10	6.52	6.94	7.35	7.77	8.18	8.59
40	1 P frigorifique	(Watt)	1354	1843	2390	3008	3710	4510	5420	6453	7623
	2 P absorbée	(W)	1160	1291	1418	1540	1661	1779	1898	2017	2138
	3 I absorbée	(A)	5.25	5.83	6.40	6.97	7.54	8.11	8.68	9.24	9.80
50	1 P frigorifique	(Watt)		1394	1866	2386	2966	3619	4360	5200	6152
	2 P absorbée	(W)		1324	1486	1643	1795	1942	2087	2230	2372
	3 I absorbée	(A)		5.92	6.64	7.37	8.09	8.80	9.52	10.2	10.9
60	1 P frigorifique	(Watt)			1341	1753	2202	2701	3263	3901	4627
	2 P absorbée	(W)			1507	1709	1904	2092	2275	2454	2629
	3 I absorbée	(A)			6.82	7.69	8.56	9.43	10.3	11.2	12.0

1 = cooling capacity 2 = power input 3 = current 4 = condensing temperature 5 = evaporating temperature

Nota : Tecumseh se réserve le droit de modifier les informations contenues dans ce document sans préavis.
Note : Tecumseh reserves the right to change information contained in this document without notification.

© 2023 Tecumseh Products Company
All rights reserved



Tecumseh

CAJ4519Z-FZ	Tension FZ : 220 - 240V 1~ 50 Hz
--------------------	---

Les performances sont données dans les conditions EN12900_MHP :	Gaz aspirés :	20.0 °C
Condition Dew	Sous refroidissement :	0.0 K
The performance data are in EN12900_MHP conditions :	Return gas :	20.0 °C
Dew Condition	Subcooling :	0.0 K

50 Hz R448A (*)											
											N°2890
4 T condensation	5 T évaporation	(°C)	-25	-20	-15	-10	-5	0	5	10	15
30	1 P frigorifique	(Watt)	1440	1949	2543	3238	4049	4991	6079	7328	8753
	2 P absorbée	(W)	982	1076	1171	1267	1365	1466	1568	1673	1781
	3 I absorbée	(A)	4.62	5.00	5.40	5.81	6.22	6.64	7.05	7.46	7.86
40	1 P frigorifique	(Watt)		1588	2127	2748	3465	4293	5248	6345	7598
	2 P absorbée	(W)		1144	1261	1378	1495	1611	1727	1844	1962
	3 I absorbée	(A)		5.16	5.70	6.24	6.79	7.34	7.90	8.45	8.99
50	1 P frigorifique	(Watt)			1694	2234	2850	3559	4375	5312	6387
	2 P absorbée	(W)			1325	1477	1626	1774	1919	2062	2204
	3 I absorbée	(A)			5.92	6.62	7.33	8.04	8.75	9.46	10.2
60	1 P frigorifique	(Watt)				1723	2233	2815	3485	4257	5147
	2 P absorbée	(W)				1536	1733	1926	2115	2299	2480
	3 I absorbée	(A)				6.91	7.79	8.68	9.57	10.5	11.3

50 Hz R449A (*)											
											N°2284
4 T condensation	5 T évaporation	(°C)	-25	-20	-15	-10	-5	0	5	10	15
30	1 P frigorifique	(Watt)	1440	1949	2543	3238	4049	4991	6079	7328	8753
	2 P absorbée	(W)	982	1076	1171	1267	1365	1466	1568	1673	1781
	3 I absorbée	(A)	4.62	5.00	5.40	5.81	6.22	6.64	7.05	7.46	7.86
40	1 P frigorifique	(Watt)		1588	2127	2748	3465	4293	5248	6345	7598
	2 P absorbée	(W)		1144	1261	1378	1495	1611	1727	1844	1962
	3 I absorbée	(A)		5.16	5.70	6.24	6.79	7.34	7.90	8.45	8.99
50	1 P frigorifique	(Watt)			1694	2234	2850	3559	4375	5312	6387
	2 P absorbée	(W)			1325	1477	1626	1774	1919	2062	2204
	3 I absorbée	(A)			5.92	6.62	7.33	8.04	8.75	9.46	10.2
60	1 P frigorifique	(Watt)				1723	2233	2815	3485	4257	5147
	2 P absorbée	(W)				1536	1733	1926	2115	2299	2480
	3 I absorbée	(A)				6.91	7.79	8.68	9.57	10.5	11.3

1 = cooling capacity 2 = power input 3 = current 4 = condensing temperature 5 = evaporating temperature

(*) Veuillez vous référer strictement aux Recommandations d'Utilisation et Bulletins Marketing Tecumseh du fait de la température de reflux élevée pour les applications LBP.
 (*) Due to very high discharge temperature especially on LBP conditions, please strictly refer to Tecumseh Guidelines & Marketing Bulletin when using this refrigerant.

Nota : Tecumseh se réserve le droit de modifier les informations contenues dans ce document sans préavis.
Note : Tecumseh reserves the right to change information contained in this document without notification.

© 2023 Tecumseh Products Company
All rights reserved