

Kompressor
Spannungscode : XC

FH2480Z-XC

Gewerbliche Kühlung (Tiefk.) (BP)

220 - 240V 1~ 50 Hz

R452A / R404A / R448A / R449A

FH2480Z-XC3A

Bedingungen	Frequenz	Nennkälteleistung		Schalleistung ISO3745 / ISO 3743-1
		Watts	BTU/h	
EN12900 / R452A	50 Hz	1146	3908	72 dBA
EN12900 / R404A	50 Hz	1281	4367	72 dBA
EN12900 / R448A	50 Hz	1003	3421	72 dBA
EN12900 / R449A	50 Hz	1003	3421	72 dBA

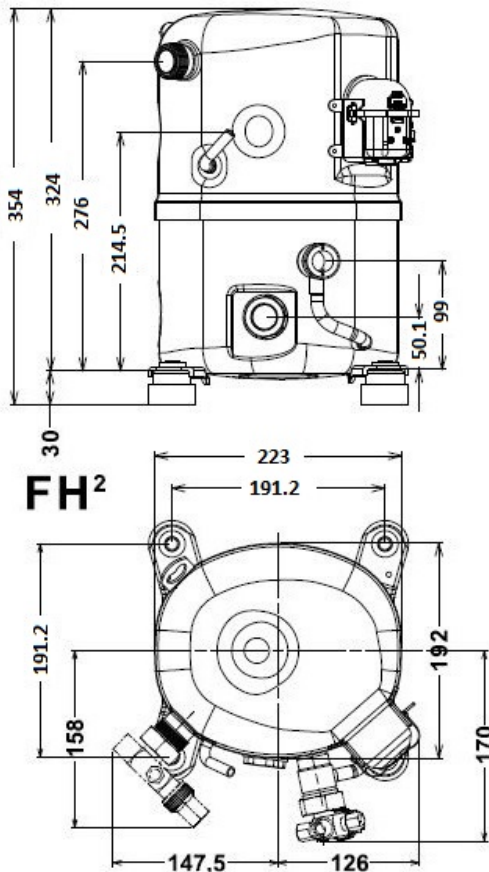

Hubvolumen (cm³)	54,3
Nettogewicht (kg)	29,0
Ölmenge (cm³)	1140,0
Ölsorte	P.O.E
Expansion	Kapillare/Expansionsventil
Kühlung	Belüftet
Hauptphase (Ohm)	0,73
Hilfsphase (Ohm)	2,07
Strom	
Nennstrom (A)	9
Maximalstrom (A)	12
Anlaufstrom (A)	65
Typ Schaltanlage	CSR
Schutz	Interne
Anlaufkondensator	156 µF / 330 V
Betriebskondensator	45 µF / 400 V
Potenzialrelais	RVA4AL**
Einschaltung	223/252V
Ausschaltung	60/121V
Außendurchmesser	
Ø Saugleitung	15,9 (5/8")
Ø Druckleitung	12,7 (1/2")
Ø Prozessleitung	6,35 (1/4")

* EN12900 : T°Verf. 40.0°C / T°Verdampf.. -35.0°C / T°Sauggastemp.. 20.0°C
T°Unter Kühlung. 0.0K

Zulassungen :



NB: Tecumseh behält sich das Recht vor, die in diesem Dokument enthaltenen Informationen ohne vorherige Ankündigung zu verändern



Tecumseh

FH2480Z-XC	Tension XC : 220 - 240V 1~ 50 Hz
-------------------	---

Les performances sont données dans les **conditions EN12900** :
 Condition Dew
 The performance data are in **EN12900 conditions** :
 Dew Condition

Gaz aspirés : 20.0 °C
 Sous refroidissement : 0.0 K
 Return gas : 20.0 °C
 Subcooling : 0.0 K

© 2023 Tecumseh Products Company
All rights reserved

50 Hz R452A

N°User-194

4 T condensation	5 T évaporation	(°C)	-40	-35	-30	-25	-20	-15	-10
30	1 P frigorifique	(Watt)	1043	1550	2180	2946	3865	4950	6217
	2 P absorbée	(W)	908	1120	1331	1537	1734	1917	2082
	3 I absorbée	(A)	6.38	6.73	7.12	7.54	8.00	8.50	9.03
40	1 P frigorifique	(Watt)	695	1146	1702	2379	3190	4151	5277
	2 P absorbée	(W)	831	1081	1335	1591	1845	2091	2325
	3 I absorbée	(A)	6.11	6.63	7.17	7.74	8.35	8.99	9.67
50	1 P frigorifique	(Watt)		745	1219	1797	2493	3322	4299
	2 P absorbée	(W)		981	1280	1587	1898	2208	2512
	3 I absorbée	(A)		6.29	6.99	7.73	8.49	9.29	10.1
60	1 P frigorifique	(Watt)				1218	1791	2479	3298
	2 P absorbée	(W)				1517	1886	2261	2636
	3 I absorbée	(A)				7.48	8.41	9.37	10.4

50 Hz R404A

N°User-193

4 T condensation	5 T évaporation	(°C)	-40	-35	-30	-25	-20	-15	-10
30	1 P frigorifique	(Watt)	1176	1700	2346	3127	4057	5150	6419
	2 P absorbée	(W)	993	1214	1432	1643	1843	2026	2190
	3 I absorbée	(A)	6.98	7.30	7.66	8.06	8.50	8.98	9.50
40	1 P frigorifique	(Watt)	817	1281	1847	2531	3345	4303	5419
	2 P absorbée	(W)	931	1190	1453	1715	1972	2220	2453
	3 I absorbée	(A)	6.84	7.30	7.80	8.34	8.92	9.54	10.2
50	1 P frigorifique	(Watt)		868	1348	1926	2615	3431	4386
	2 P absorbée	(W)		1110	1418	1732	2047	2359	2663
	3 I absorbée	(A)		7.11	7.75	8.44	9.16	9.92	10.7
60	1 P frigorifique	(Watt)			865	1329	1887	2551	3337
	2 P absorbée	(W)			1325	1690	2063	2440	2816
	3 I absorbée	(A)			7.51	8.33	9.20	10.1	11.1

1 = cooling capacity 2 = power input 3 = current 4 = condensing temperature 5 = evaporating temperature

Nota : Tecumseh se réserve le droit de modifier les informations contenues dans ce document sans préavis.

Note : Tecumseh reserves the right to change information contained in this document without notification.



Tecumseh

FH2480Z-XC	Tension XC : 220 - 240V 1~ 50 Hz
-------------------	---

Les performances sont données dans les **conditions EN12900** :
 Condition Dew
 The performance data are in **EN12900 conditions** :
 Dew Condition

Gaz aspirés : 20.0 °C
 Sous refroidissement : 0.0 K
 Return gas : 20.0 °C
 Subcooling : 0.0 K

50 Hz R448A (*)								
N°User-196								
4 T condensation	5 T évaporation	(°C)	-35	-30	-25	-20	-15	-10
30	1 P frigorifique	(Watt)	1359	1947	2672	3549	4597	5831
	2 P absorbée	(W)	1037	1240	1440	1631	1809	1970
	3 I absorbée	(A)	6.23	6.63	7.06	7.53	8.02	8.55
40	1 P frigorifique	(Watt)	1003	1530	2180	2968	3911	5027
	2 P absorbée	(W)	994	1239	1488	1734	1975	2205
	3 I absorbée	(A)	6.10	6.65	7.24	7.85	8.49	9.17
50	1 P frigorifique	(Watt)	646	1106	1674	2367	3201	4194
	2 P absorbée	(W)	894	1182	1479	1782	2086	2386
	3 I absorbée	(A)	5.73	6.46	7.20	7.98	8.78	9.61
60	1 P frigorifique	(Watt)			1175	1766	2486	3349
	2 P absorbée	(W)			1409	1769	2136	2506
	3 I absorbée	(A)			6.94	7.89	8.85	9.85

50 Hz R449A (*)								
N°User-195								
4 T condensation	5 T évaporation	(°C)	-35	-30	-25	-20	-15	-10
30	1 P frigorifique	(Watt)	1359	1947	2672	3549	4597	5831
	2 P absorbée	(W)	1037	1240	1440	1631	1809	1970
	3 I absorbée	(A)	6.23	6.63	7.06	7.53	8.02	8.55
40	1 P frigorifique	(Watt)	1003	1530	2180	2968	3911	5027
	2 P absorbée	(W)	994	1239	1488	1734	1975	2205
	3 I absorbée	(A)	6.10	6.65	7.24	7.85	8.49	9.17
50	1 P frigorifique	(Watt)	646	1106	1674	2367	3201	4194
	2 P absorbée	(W)	894	1182	1479	1782	2086	2386
	3 I absorbée	(A)	5.73	6.46	7.20	7.98	8.78	9.61
60	1 P frigorifique	(Watt)			1175	1766	2486	3349
	2 P absorbée	(W)			1409	1769	2136	2506
	3 I absorbée	(A)			6.94	7.89	8.85	9.85

1 = cooling capacity 2 = power input 3 = current 4 = condensing temperature 5 = evaporating temperature

(*) Veuillez vous référer strictement aux Recommandations d'Utilisation et Bulletins Marketing Tecumseh du fait de la température de reflux élevée pour les applications LBP.
 (*) Due to very high discharge temperature especially on LBP conditions, please strictly refer to Tecumseh Guidelines & Marketing Bulletin when using this refrigerant.

Nota : Tecumseh se réserve le droit de modifier les informations contenues dans ce document sans préavis.

Note : Tecumseh reserves the right to change information contained in this document without notification.

© 2023 Tecumseh Products Company
All rights reserved