



Tecumseh

Kompressor
Spannungscode : FZ

THB4422YFZ

Gewerbliche Kühlung (Normalk.) (HP)

220 - 240V 1~ 50 Hz

R134a / R513A

THB4422YFZ

Bedingungen	Frequenz	Nennkälteleistung		Schalleistung ISO3745 / ISO 3743-1
		Watts	BTU/h	
EN12900_MHP / R134a	50 Hz	264	901	47 dBA
EN12900_MHP / R513A	50 Hz	281	959	47 dBA

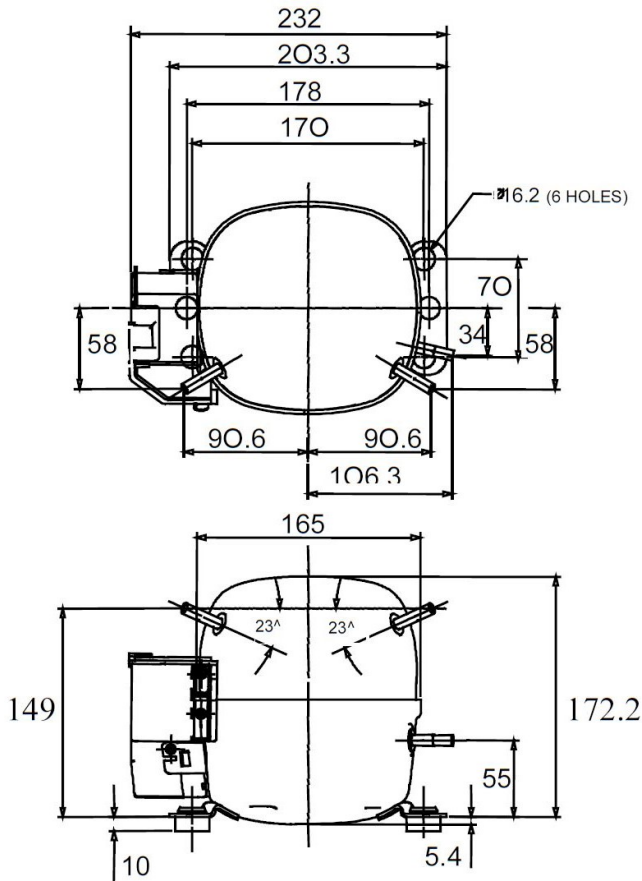

* EN12900_MHP : T°Verf. 45.0°C / T°Verdampf.. -10.0°C / T°Sauggastemp.. 20.0°C
T°Unterkühlung. 0.0K

Zulassungen :



Hubvolumen (cm³)	5,9
Nettogewicht (kg)	7,4
Ölmenge (cm³)	250,0
Ölsorte	P.O.E
Expansion	Kapillare/Expansionsventil
Kühlung	Belüftet
Hauptphase (Ohm)	11,7
Hilfsphase (Ohm)	22,5
Strom	
Nennstrom (A)	1,6
Maximalstrom (A)	1,8
Anlaufstrom (A)	9
Typ Schaltanlage	CSIR
Schutz	T8826
Verzögerung	6,5s - 16s / 7 A
Öffnungs-Temp.	110° C
Schließ-Temp.	52° C
Anlaufkondensator	72-88 µF / 250 V
Stromrelais	9660C-***-124
Einschaltung	4,57A
Ausschaltung	3,85A
Optional	RP37**
Außendurchmesser	
Ø Saugleitung	6,35 (1/4")
Ø Druckleitung	6,35 (1/4")
Ø Prozessleitung	4,76 (3/16")

NB: Tecumseh behält sich das Recht vor, die in diesem Dokument enthaltenen Informationen ohne vorherige Ankündigung zu verändern



Tecumseh

THB4422YFZ	Tension FZ : 220 - 240V 1~ 50 Hz
-------------------	---

Les performances sont données dans les **conditions EN12900_MHP** :
 Condition Dew
 The performance data are in **EN12900_MHP conditions** :
 Dew Condition

Gaz aspirés : 20.0 °C
 Sous refroidissement : 0.0 K
 Return gas : 20.0 °C
 Subcooling : 0.0 K

50 Hz R134a											
N°211LS-FZ											
4 T condensation	5 T évaporation	(°C)	-25	-20	-15	-10	-5	0	5	10	15
30	1 P frigorifique	(Watt)	148	196	255	324	406	500	610	736	879
	2 P absorbée	(W)	127	139	152	164	177	191	206	222	239
	3 I absorbée	(A)	1.30	1.31	1.33	1.35	1.38	1.42	1.46	1.51	1.57
40	1 P frigorifique	(Watt)	125	170	223	285	358	443	541	653	782
	2 P absorbée	(W)	131	146	161	176	192	209	226	245	266
	3 I absorbée	(A)	1.29	1.31	1.34	1.37	1.42	1.46	1.52	1.58	1.65
50	1 P frigorifique	(Watt)		143	189	243	307	380	466	564	676
	2 P absorbée	(W)		150	168	187	206	226	247	270	294
	3 I absorbée	(A)		1.31	1.35	1.40	1.45	1.51	1.58	1.65	1.73
60	1 P frigorifique	(Watt)			157	202	255	316	387	470	565
	2 P absorbée	(W)			173	196	219	243	269	295	323
	3 I absorbée	(A)			1.37	1.43	1.50	1.57	1.65	1.73	1.82

50 Hz R513A											
N°3192											
4 T condensation	5 T évaporation	(°C)	-25	-20	-15	-10	-5	0	5	10	15
30	1 P frigorifique	(Watt)	170	222	283	352	432	523	627	743	873
	2 P absorbée	(W)	142	153	164	176	189	204	222	243	270
	3 I absorbée	(A)	1.45	1.44	1.44	1.45	1.47	1.51	1.57	1.66	1.76
40	1 P frigorifique	(Watt)	141	188	243	306	379	462	556	662	782
	2 P absorbée	(W)	143	158	173	188	203	220	239	262	289
	3 I absorbée	(A)	1.41	1.42	1.44	1.46	1.50	1.54	1.61	1.69	1.79
50	1 P frigorifique	(Watt)		155	202	256	319	391	474	567	673
	2 P absorbée	(W)		159	179	198	217	237	259	284	312
	3 I absorbée	(A)		1.40	1.44	1.48	1.53	1.59	1.66	1.74	1.84
60	1 P frigorifique	(Watt)			165	208	258	317	386	464	554
	2 P absorbée	(W)			181	205	230	254	280	309	340
	3 I absorbée	(A)			1.44	1.50	1.57	1.64	1.72	1.81	1.91

1 = cooling capacity 2 = power input 3 = current 4 = condensing temperature 5 = evaporating temperature

Nota : Tecumseh se réserve le droit de modifier les informations contenues dans ce document sans préavis.

Note : Tecumseh reserves the right to change information contained in this document without notification.

© 2023 Tecumseh Products Company
All rights reserved